



BF423

PNP SILICON TRANSISTOR

PNP HIGH-VOLTAGE TRANSISTORS

FEATURES

* Collector-Emitter Voltage: $V_{CE0}=-250V$

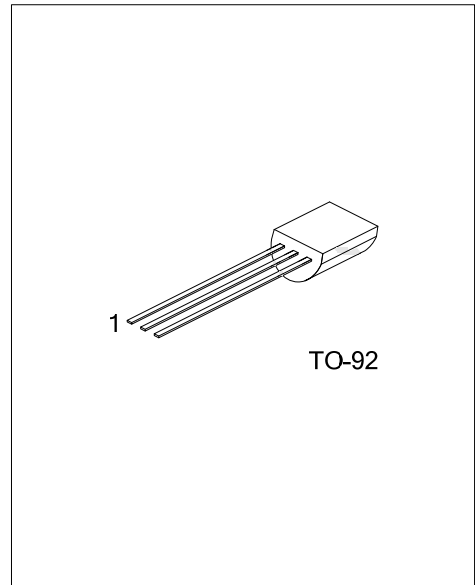

ORDERING INFORMATION

Ordering Number		Package	Pin Assignment			Packing
Lead Free	Halogen Free		1	2	3	
BF423L-T92-B	BF423G-T92-B	TO-92	E	C	B	Tape Box
BF423L-T92-K	BF423G-T92-K	TO-92	E	C	B	Bulk

Note: Pin Assignment: G: Gate S: Source D: Drain

<p>BF423G-T92-B</p> <p>(1)Packing Type (2)Package Type (3)Green Package</p>	<p>(1) B: Tape Box, K: Bulk (2) T92: TO-92 (3) G: Halogen Free and Lead Free, L: Lead Free</p>
---	--

MARKING

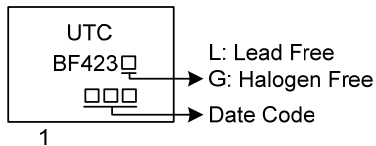

■ ABSOLUTE MAXIMUM RATING ($T_A=25^{\circ}\text{C}$, unless otherwise specified)

PARAMETER	SYMBOL	RATINGS	UNIT
Collector-base voltage	V_{CBO}	-250	V
Collector-emitter voltage	V_{CEO}	-250	V
Emitter-base voltage	V_{EBO}	-5	V
Collector current (DC)	I_C	-50	mA
collector current (Peak)	I_{CP}	-100	mA
base current	I_B	-50	mA
Collector Power dissipation	P_C	625	mW
Junction Temperature	T_J	125	$^{\circ}\text{C}$
Operating Temperature	T_{OPR}	-20 ~ +85	$^{\circ}\text{C}$
Storage Temperature	T_{STG}	-40 ~ +150	$^{\circ}\text{C}$

Note: Absolute maximum ratings are those values beyond which the device could be permanently damaged. Absolute maximum ratings are stress ratings only and functional device operation is not implied.

■ ELECTRICAL CHARACTERISTICS ($T_A=25^{\circ}\text{C}$, unless otherwise specified)

PARAMETER	SYMBOL	TEST CONDITIONS	MIN	TYP	MAX	UNIT
Collector Cut-Off Current	I_{CBO}	$V_{CB} = -200\text{V}, I_E = 0$			-10	nA
		$V_{CB} = -200\text{V}, I_E = 0, T_J = 150^{\circ}\text{C}$			-10	μA
Emitter Cut-Off Current	I_{EBO}	$V_{EB} = -5\text{V}, I_C = 0$			-50	nA
DC current gain	h_{FE}	$V_{CE} = -20\text{V}, I_C = -25\text{mA}$	50			
Collector-emitter saturation voltage	$V_{CE(sat)}$	$I_C = -30\text{mA}, I_B = -5\text{mA}$			-0.6	V
Transition frequency	f_T	$V_{CE} = -10\text{V}, I_C = -10\text{mA}, f = 100\text{MHz}$	60			MHz
Feedback capacitance	C_{re}	$V_{CB} = -30\text{V}, I_E = 0, f = 1\text{MHz}$			1.6	pF

TYPICAL CHARACTERISTICS

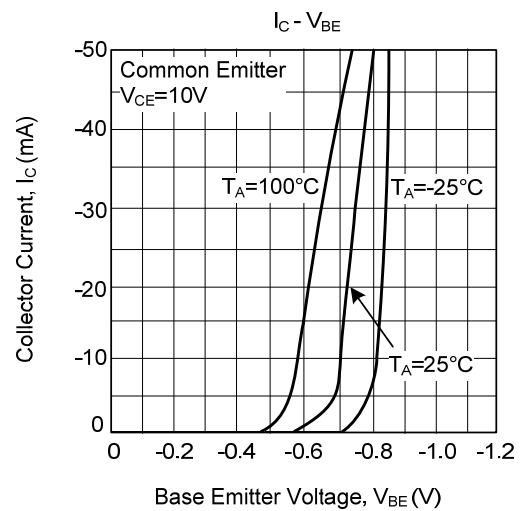
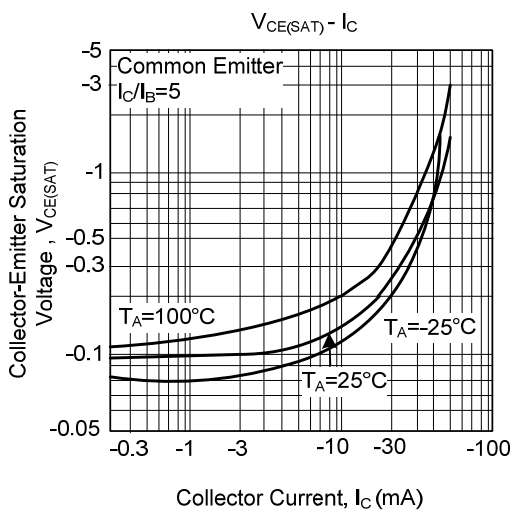
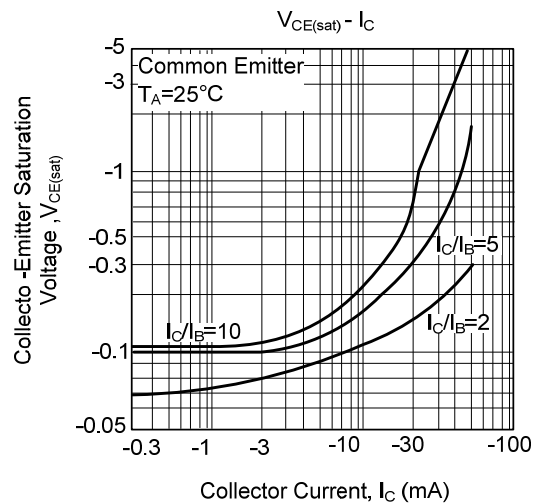
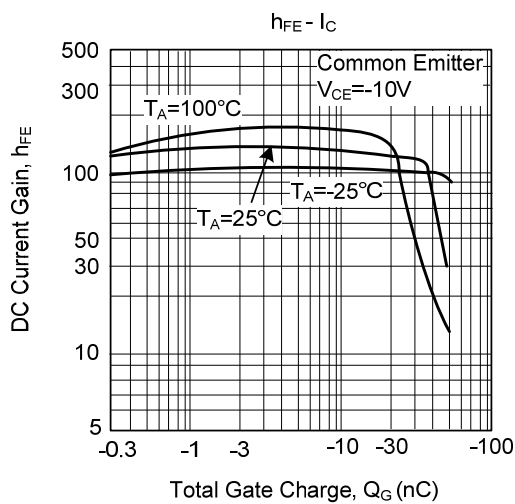
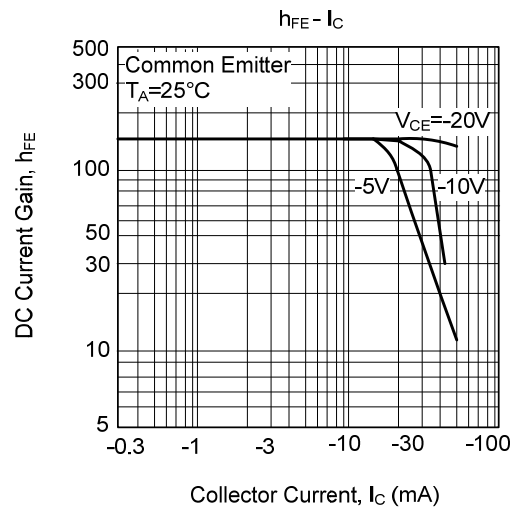
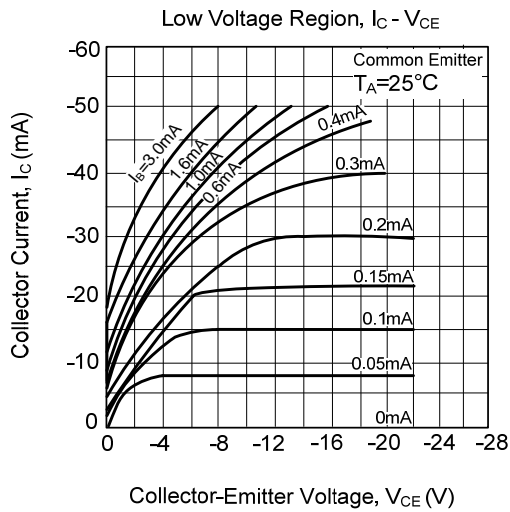

■ TYPICAL CHARACTERISTICS (Cont.)

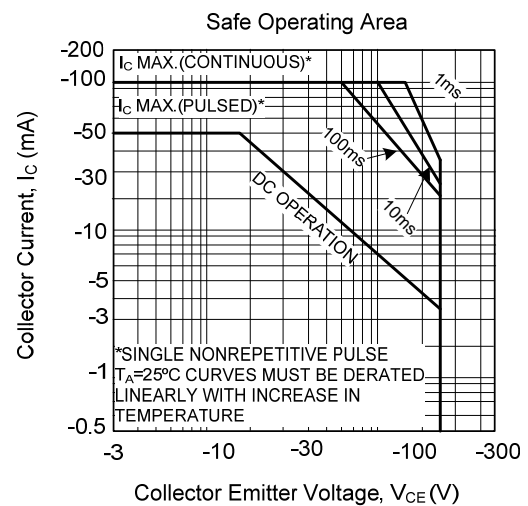
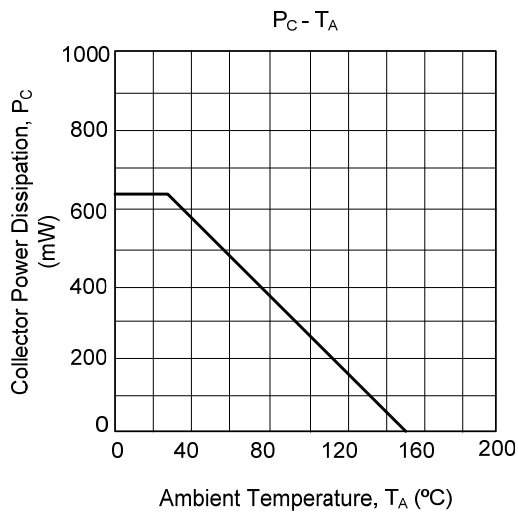
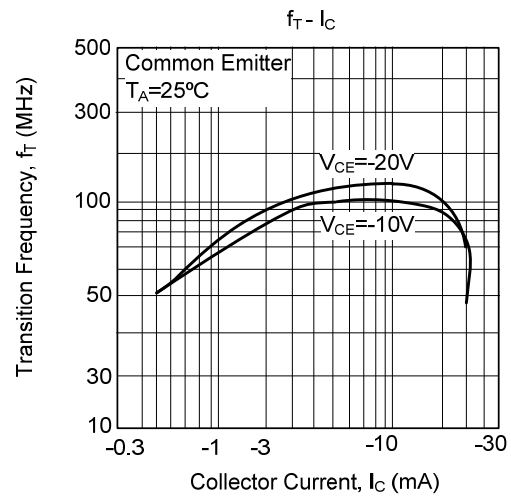
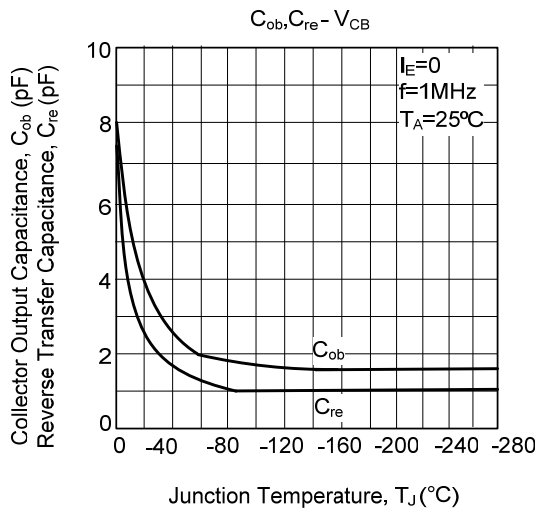

UTC assumes no responsibility for equipment failures that result from using products at values that exceed, even momentarily, rated values (such as maximum ratings, operating condition ranges, or other parameters) listed in products specifications of any and all UTC products described or contained herein. UTC products are not designed for use in life support appliances, devices or systems where malfunction of these products can be reasonably expected to result in personal injury. Reproduction in whole or in part is prohibited without the prior written consent of the copyright owner. UTC reserves the right to make changes to information published in this document, including without limitation specifications and product descriptions, at any time and without notice. This document supersedes and replaces all information supplied prior to the publication hereof.