

PNP Silicon RF Transistor

BF 606 A

- For VHF oscillator stages

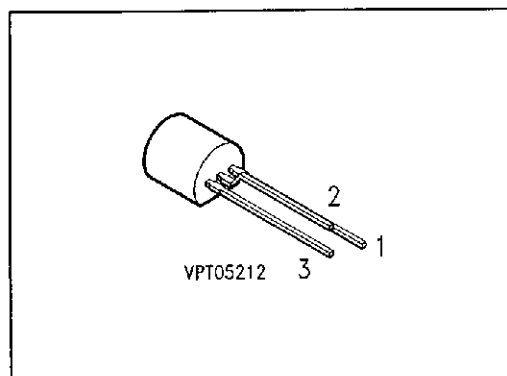

Type	Marking	Ordering Code	Pin Configuration			Package ¹⁾
			1	2	3	
BF 606 A	–	Q62702-F535	C	E	B	TO-92

Maximum Ratings

Parameter	Symbol	Values	Unit
Collector-emitter voltage	V_{CE0}	30	V
Collector-base voltage	V_{CB0}	40	
Emitter-base voltage	V_{EB0}	4	
Collector current	I_C	25	mA
Emitter current	I_E	30	
Total power dissipation, $T_A \leq 45 \text{ }^\circ\text{C}$	P_{tot}	300	mW
Junction temperature	T_j	150	$^\circ\text{C}$
Storage temperature range	T_{stg}	– 55 ... + 150	

Thermal Resistance

Junction - ambient	$R_{th JA}$	≤ 350	K/W
--------------------	-------------	------------	-----

¹⁾ For detailed information see chapter Package Outlines.

Electrical Characteristicsat $T_A = 25\text{ °C}$, unless otherwise specified.

Parameter	Symbol	Values			Unit
		min.	typ.	max.	

DC Characteristics

Collector-emitter breakdown voltage $I_C = 2\text{ mA}$	$V_{(BR)CE0}$	30	–	–	V
Collector-base breakdown voltage $I_C = 10\text{ }\mu\text{A}$	$V_{(BR)CB0}$	40	–	–	
Emitter-base breakdown voltage $I_E = 10\text{ }\mu\text{A}$	$V_{(BR)EB0}$	4	–	–	
Collector cutoff current $V_{CB} = 20\text{ V}$	I_{CB0}	–	–	60	nA
DC current gain $I_C = 1\text{ mA}$, $V_{CE} = 10\text{ V}$	h_{FE}	30	–	–	–

AC Characteristics

Transition frequency $I_C = 5\text{ mA}$, $V_{CE} = 10\text{ V}$, $f = 100\text{ MHz}$	f_T	–	700	–	MHz
Collector-emitter capacitance $V_{CE} = 10\text{ V}$, $V_{BE} = 0\text{ V}$, $f = 1\text{ MHz}$	C_{ce}	–	0.35	–	pF
Collector-base capacitance $V_{CB} = 10\text{ V}$, $V_{BE} = 0\text{ V}$, $f = 1\text{ MHz}$	C_{cb}	–	–	0.85	