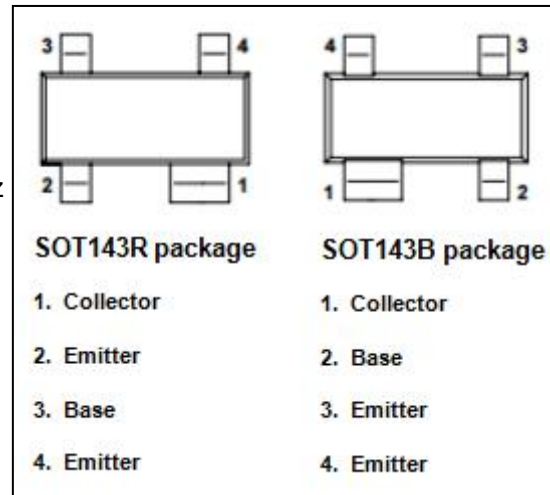

**isc Silicon NPN RF Transistor**
**BFG540**
**DESCRIPTION**

- Low Noise Figure  
 $NF = 1.3 \text{ dB TYP. @ } V_{CE} = 8 \text{ V, } I_C = 10 \text{ mA, } f = 900 \text{ MHz}$
- High Gain  
 $|S_{21}|^2 = 16 \text{ dB TYP. @ } V_{CE} = 8 \text{ V, } I_C = 40 \text{ mA, } f = 900 \text{ MHz}$
- Minimum Lot-to-Lot variations for robust device performance and reliable operation

**APPLICATIONS**

- Designed for use in low noise ,high-gain amplifiers and linear broadband amplifiers.

**ABSOLUTE MAXIMUM RATINGS( $T_a=25^\circ\text{C}$ )**

SYMBOL	PARAMETER	VALUE	UNIT
$V_{CBO}$	Collector-Base Voltage	20	V
$V_{CEO}$	Collector-Emitter Voltage	15	V
$V_{EBO}$	Emitter-Base Voltage	2.5	V
$I_C$	Collector Current-Continuous	120	mA
$P_C$	Collector Power Dissipation @ $T_c=25^\circ\text{C}$	0.5	W
$T_J$	Junction Temperature	150	$^\circ\text{C}$
$T_{stg}$	Storage Temperature Range	-65~150	$^\circ\text{C}$

**isc Silicon NPN RF Transistor**
**BFG540**
**ELECTRICAL CHARACTERISTICS**

 T<sub>c</sub>=25°C unless otherwise specified

SYMBOL	PARAMETER	CONDITIONS	MIN	TYP.	MAX	UNIT
V <sub>(BR)CEO</sub>	Collector-Emitter Breakdown Voltage	I <sub>C</sub> = 1mA ; I <sub>B</sub> = 0	12			V
I <sub>CBO</sub>	Collector Cutoff Current	V <sub>CB</sub> = 8V ; I <sub>E</sub> = 0			0.05	μ A
h <sub>FE</sub>	DC Current Gain	I <sub>C</sub> =40mA ; V <sub>CE</sub> = 8V	60		250	
f <sub>T</sub>	Current-Gain—Bandwidth Product	I <sub>C</sub> = 40mA ; V <sub>CE</sub> = 8V; f= 1MHz		9		GHz
C <sub>re</sub>	Feedback Capacitance	I <sub>E</sub> = 0 ; V <sub>CB</sub> = 8V; f= 1MHz		0.5		pF
C <sub>e</sub>	Emitter capacitance	I <sub>C</sub> =i <sub>C</sub> =0, V <sub>EB</sub> =0.5V, f=1MHz		2.0		pF
C <sub>c</sub>	Collector capacitance	I <sub>E</sub> =i <sub>e</sub> =0, V <sub>CB</sub> =8V, f=1MHz		0.9		pF
S <sub>21</sub>   <sup>2</sup>	Insertion Power Gain	I <sub>C</sub> = 40mA ; V <sub>CE</sub> = 8V; f= 900MHz	15	16		dB
NF	Noise Figure	I <sub>C</sub> = 10mA ; V <sub>CE</sub> = 8V; f= 900MHz		1.3	1.8	dB
		I <sub>C</sub> = 40mA ; V <sub>CE</sub> = 8V; f= 900MHz		1.9	2.4	
		I <sub>C</sub> = 10mA ; V <sub>CE</sub> = 8V; f= 2GHz		2.1		

isc Silicon NPN RF Transistor

BFG540

PACKAGE SIZE DRAWING

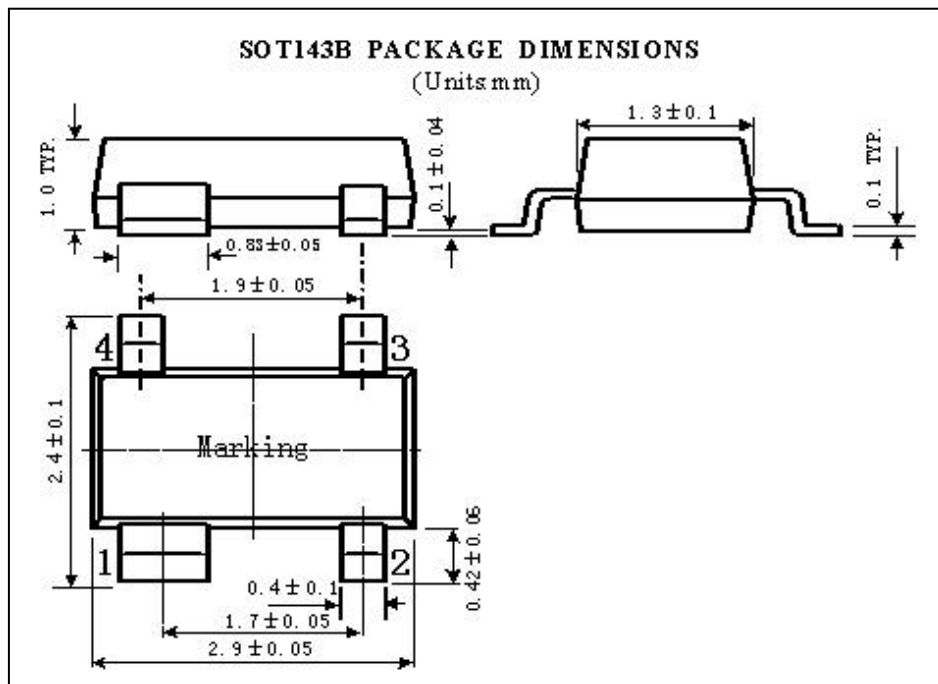
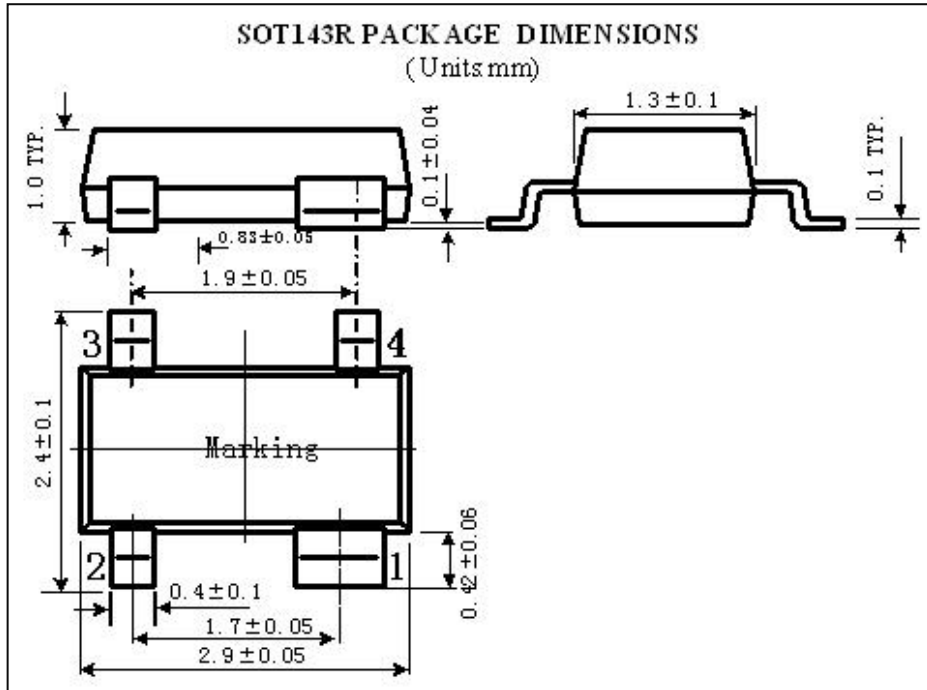

**NOTICE:**

ISC reserves the rights to make changes of the content herein the datasheet at any time without notification. The information contained herein is presented only as a guide for the applications of our products.

ISC products are intended for usage in general electronic equipment. The products are not designed for use in equipment which require specialized quality and/or reliability, or in equipment which could have applications in hazardous environments, aerospace industry, or medical field. Please contact us if you intend our products to be used in these special applications.

ISC makes no warranty or guarantee regarding the suitability of its products for any particular purpose, nor does ISC assume any liability arising from the application or use of any products, and specifically disclaims any and all liability, including without limitation special, consequential or incidental damages.