

## NPN 6 GHz wideband transistor

 BFG91A

## DESCRIPTION

NPN transistor in a 4-lead dual-emitter plastic SOT103 envelope.

It is designed for application in wideband amplifiers, such as MATV and CATV systems.

## PINNING

PIN	DESCRIPTION
1	emitter
2	collector
3	emitter
4	base

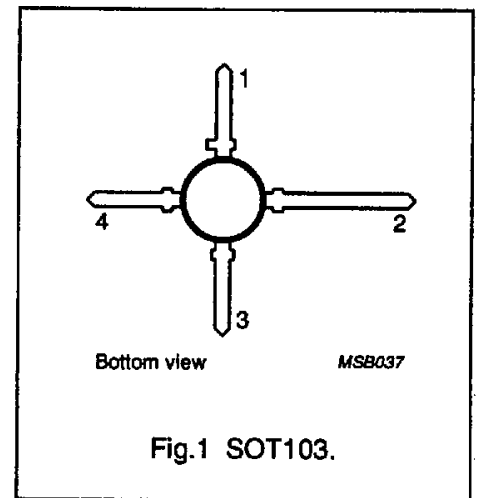

www.DataSheet4U.com

## QUICK REFERENCE DATA

SYMBOL	PARAMETER	CONDITIONS	MIN.	TYP.	MAX.	UNIT
$V_{CBO}$	collector-base voltage	open emitter	–	–	15	V
$V_{CEO}$	collector-emitter voltage	open base	–	–	12	V
$I_C$	DC collector current		–	–	35	mA
$P_{tot}$	total power dissipation	up to $T_s = 158\text{ °C}$ (note 1)	–	–	300	mW
$h_{FE}$	DC current gain	$I_C = 30\text{ mA}$ ; $V_{CE} = 5\text{ V}$ ; $T_j = 25\text{ °C}$	40	90	–	
$f_T$	transition frequency	$I_C = 30\text{ mA}$ ; $V_{CE} = 5\text{ V}$ ; $f = 500\text{ MHz}$ ; $T_j = 25\text{ °C}$	–	6	–	GHz
$C_{fb}$	feedback capacitance	$I_C = 0$ ; $V_{CE} = 5\text{ V}$ ; $f = 1\text{ MHz}$	–	0.5	–	pF
$G_{UM}$	maximum unilateral power gain	$I_C = 30\text{ mA}$ ; $V_{CE} = 8\text{ V}$ ; $f = 800\text{ MHz}$ ; $T_{amb} = 25\text{ °C}$	–	17.5	–	dB
$F$	noise figure	$I_C = 30\text{ mA}$ ; $V_{CE} = 8\text{ V}$ ; $Z_S = \text{opt.}$ ; $f = 800\text{ MHz}$ ; $T_{amb} = 25\text{ °C}$	–	2.3	–	dB
$P_{L1}$	output power at 1 dB gain compression	$I_C = 30\text{ mA}$ ; $V_{CE} = 8\text{ V}$ ; $R_L = 75\text{ }\Omega$ ; $f = 800\text{ MHz}$ ; $T_{amb} = 25\text{ °C}$	–	17	–	dBm
ITO	third order intercept point	$I_C = 30\text{ mA}$ ; $V_{CE} = 8\text{ V}$ ; $R_L = 75\text{ }\Omega$ ; $f = 800\text{ MHz}$ ; $T_{amb} = 25\text{ °C}$	–	36	–	dBm

## Note

1.  $T_s$  is the temperature at the soldering point of the collector lead.

## NPN 6 GHz wideband transistor

BFG91A

**LIMITING VALUES**

In accordance with the Absolute Maximum System (IEC 134).

SYMBOL	PARAMETER	CONDITIONS	MIN.	MAX.	UNIT
$V_{CBO}$	collector-base voltage	open emitter	–	15	V
$V_{CEO}$	collector-emitter voltage	open base	–	12	V
$V_{EBO}$	emitter-base voltage	open collector	–	2	V
$I_C$	DC collector current		–	35	mA
$I_{CM}$	peak collector current	$f > 1$ MHz	–	50	mA
$P_{tot}$	total power dissipation	up to $T_s = 158$ °C (note 1)	–	300	mW
$T_{stg}$	storage temperature		–65	150	°C
$T_j$	junction temperature		–	175	°C

**THERMAL RESISTANCE**

SYMBOL	PARAMETER	CONDITIONS	THERMAL RESISTANCE
$R_{th\ j-s}$	thermal resistance from junction to soldering point	up to $T_s = 158$ °C (note 1)	55 K/W

**Note**

- $T_s$  is the temperature at the soldering point of the collector lead.

## NPN 6 GHz wideband transistor

BFG91A

## CHARACTERISTICS

 $T_j = 25\text{ °C}$  unless otherwise specified.

SYMBOL	PARAMETER	CONDITIONS	MIN.	TYP.	MAX.	UNIT
$I_{CBO}$	collector cut-off current	$I_E = 0; V_{CB} = 5\text{ V}$	–	–	50	nA
$h_{FE}$	DC current gain	$I_C = 30\text{ mA}; V_{CE} = 5\text{ V}$	40	90	–	
$C_c$	collector capacitance	$I_E = I_B = 0; V_{CB} = 10\text{ V}; f = 1\text{ MHz}$	–	0.9	–	pF
$C_e$	emitter capacitance	$I_C = I_C = 0; V_{EB} = 0.5\text{ V}; f = 1\text{ MHz}$	–	2.5	–	pF
$C_{fb}$	feedback capacitance	$I_C = 0; V_{CE} = 5\text{ V}; f = 1\text{ MHz}$	–	0.5	–	pF
$f_T$	transition frequency	$I_C = 30\text{ mA}; V_{CE} = 5\text{ V}; f = 500\text{ MHz}$	–	6	–	GHz
$G_{UM}$	maximum unilateral power gain (note 1)	$I_C = 30\text{ mA}; V_{CE} = 8\text{ V}; f = 800\text{ MHz};$ $T_{amb} = 25\text{ °C}$	–	17.5	–	dB
		$I_C = 30\text{ mA}; V_{CE} = 8\text{ V}; f = 2\text{ GHz};$ $T_{amb} = 25\text{ °C}$	–	9.5	–	dB
F	noise figure	$I_C = 4\text{ mA}; V_{CE} = 8\text{ V}; Z_S = \text{opt.};$ $f = 800\text{ MHz}; T_{amb} = 25\text{ °C}$	–	1.6	–	dB
		$I_C = 30\text{ mA}; V_{CE} = 8\text{ V}; Z_S = \text{opt.};$ $f = 800\text{ MHz}; T_{amb} = 25\text{ °C}$	–	2.3	–	dB
$P_{L1}$	output power at 1 dB gain compression	$V_{CE} = 8\text{ V}; I_C = 30\text{ mA}; R_L = 75\text{ }\Omega;$ $f = 800\text{ MHz}; T_{amb} = 25\text{ °C}$	–	17	–	dBm
ITO	third order intercept point (see Fig. 2)	note 2	–	36	–	dBm
$V_O$	output voltage	note 3	–	425	–	mV
$d_2$	second order intermodulation distortion (see Fig.2)	note 4	–	–50	–	dB

## Notes

- $G_{UM}$  is the maximum unilateral power gain, assuming  $S_{12}$  is zero and  $G_{UM} = 10 \log \frac{|S_{21}|^2}{(1 - |S_{11}|^2)(1 - |S_{22}|^2)}$  dB.
- $I_C = 30\text{ mA}; V_{CE} = 8\text{ V}; R_L = 75\text{ }\Omega; T_{amb} = 25\text{ °C};$   
 $P_p = \text{ITO} - 6\text{ dB}; f_p = 800\text{ MHz};$   
 $P_q = \text{ITO} - 6\text{ dB}; f_q = 801\text{ MHz};$   
 measured at  $f_{(2q-p)} = 802\text{ MHz}$  and at  $f_{(2p-q)} = 799\text{ MHz}.$
- $d_{im} = -60\text{ dB}; I_C = 30\text{ mA}; V_{CE} = 8\text{ V}; R_L = 75\text{ }\Omega; T_{amb} = 25\text{ °C};$   
 $V_p = V_O$  at  $d_{im} = -60\text{ dB}; f_p = 795.25\text{ MHz};$   
 $V_q = V_O - 6\text{ dB}; f_q = 803.25\text{ MHz};$   
 $V_r = V_O - 6\text{ dB}; f_r = 805.25\text{ MHz};$   
 measured at  $f_{(p+q-r)} = 793.25\text{ MHz}.$
- $I_C = 30\text{ mA}; V_{CE} = 8\text{ V}; R_L = 75\text{ }\Omega; \text{VSWR} < 2; T_{amb} = 25\text{ °C};$   
 $V_p = V_O = 200\text{ mV}$  at  $f_p = 250\text{ MHz};$   
 $V_q = V_O = 200\text{ mV}$  at  $f_q = 560\text{ MHz};$   
 measured at  $f_{(p+q)} = 810\text{ MHz}.$

NPN 6 GHz wideband transistor

BFG91A

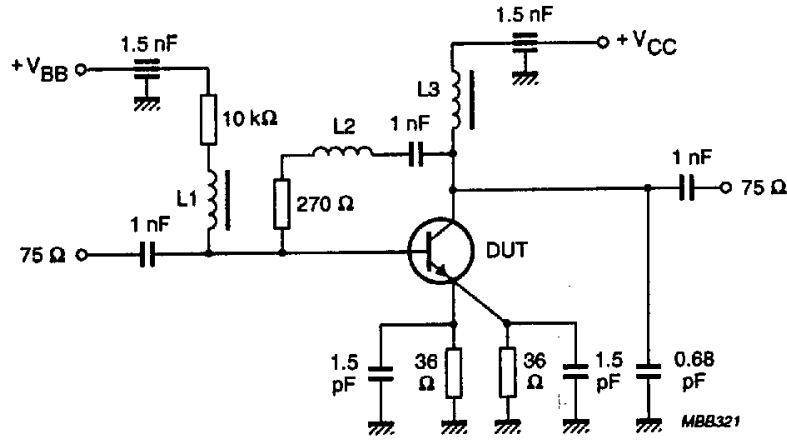

www.DataSheet4U.com

L1 = L3 = 5  $\mu$ H Ferroxcube choke.  
 L2 = 3 turns 0.4 mm copper wire, internal diameter 3 mm, winding pitch 1 mm.

Fig.2 Intermodulation distortion and second order intermodulation distortion MATV test circuit.

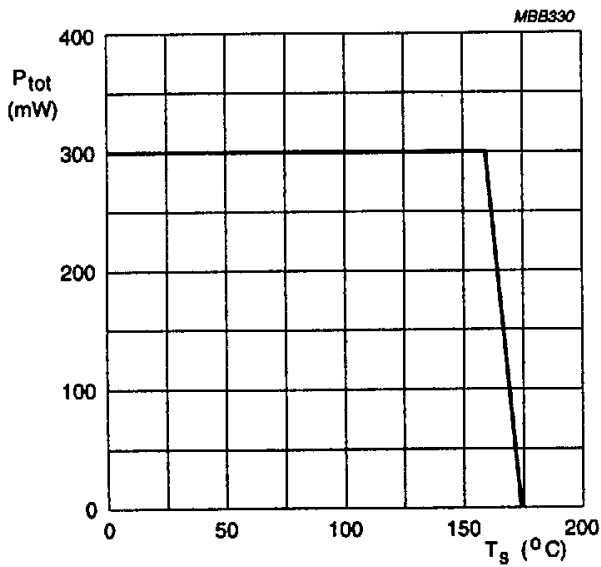
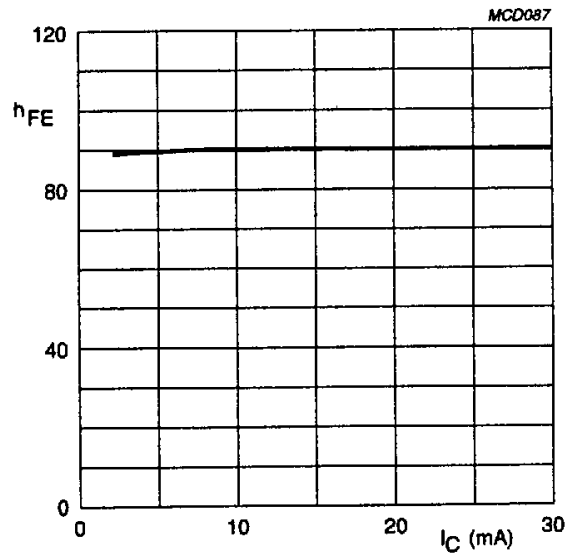

Fig.3 Power derating curve.



$V_{CE} = 5$  V;  $T_j = 25$  °C.

Fig.4 DC current gain as a function of collector current.

NPN 6 GHz wideband transistor

BFG91A

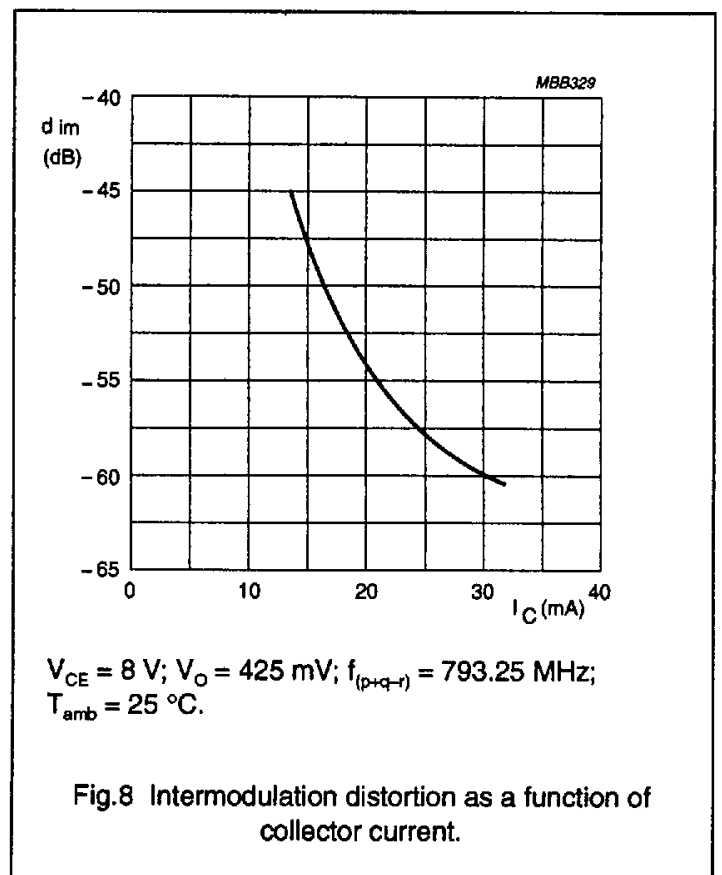
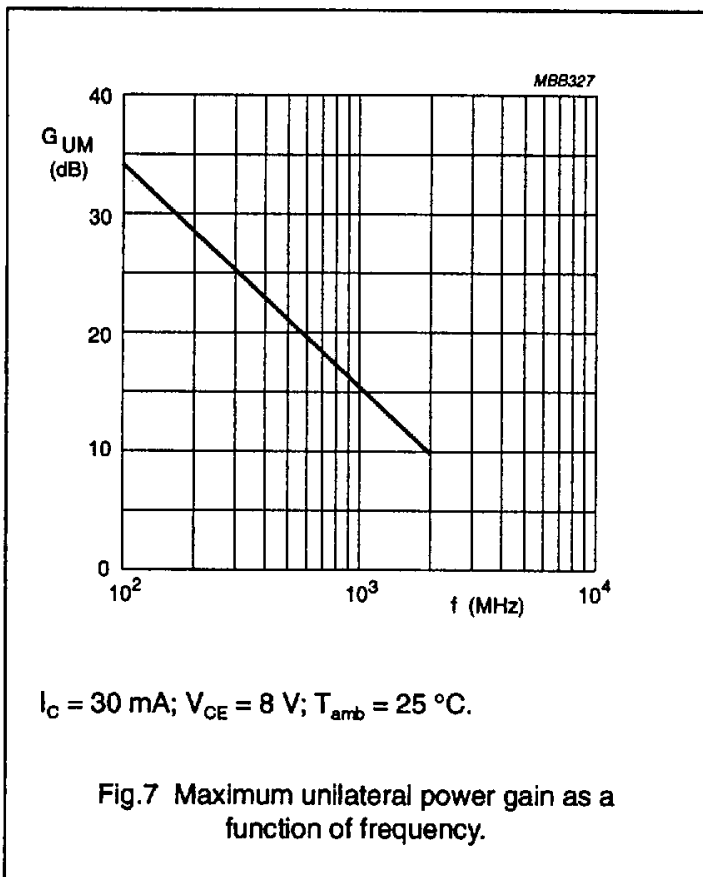
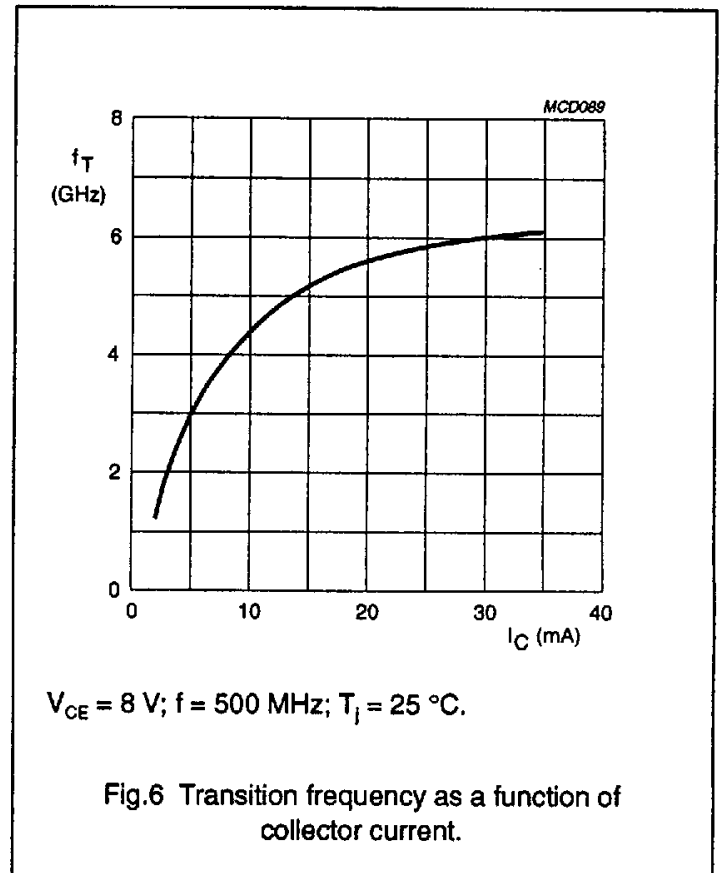
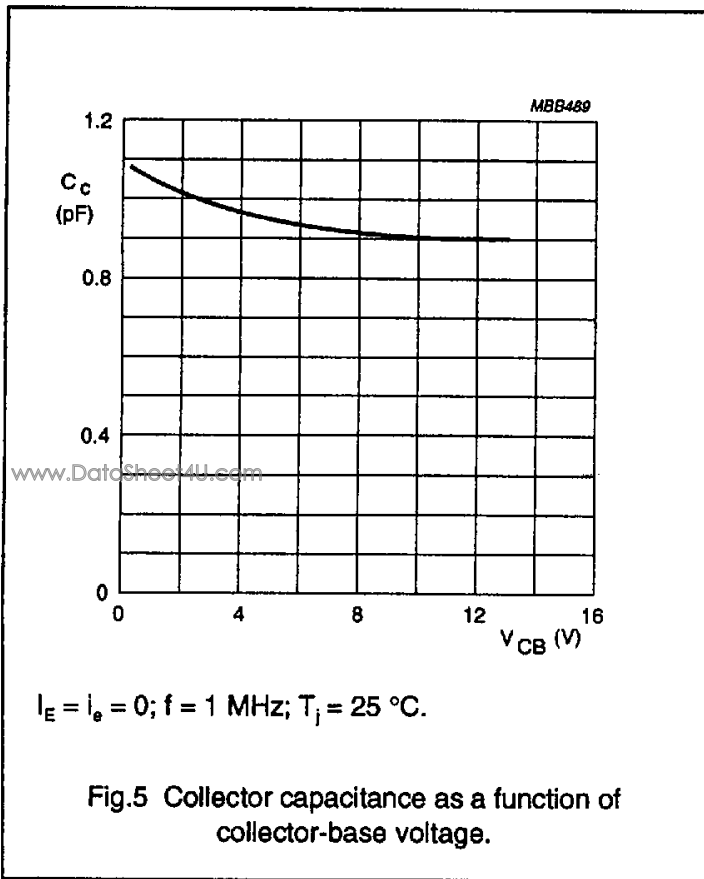

NPN 6 GHz wideband transistor

BFG91A

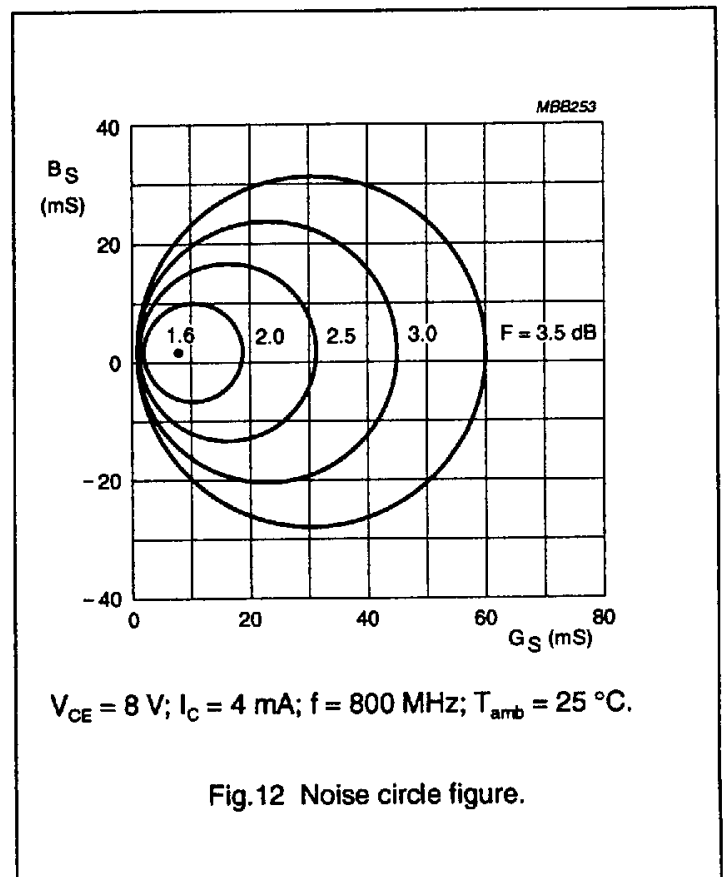
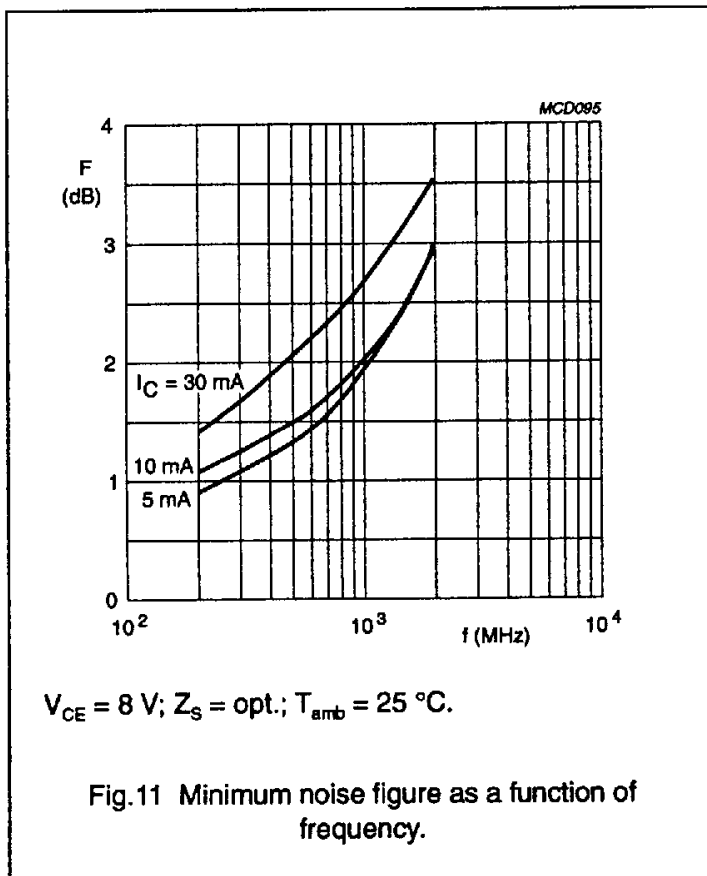
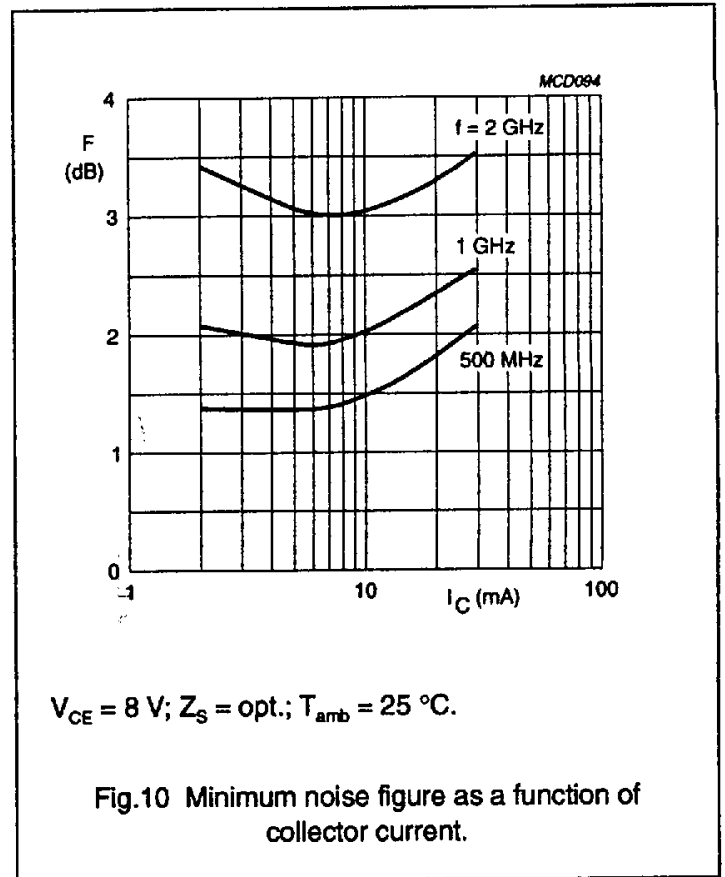
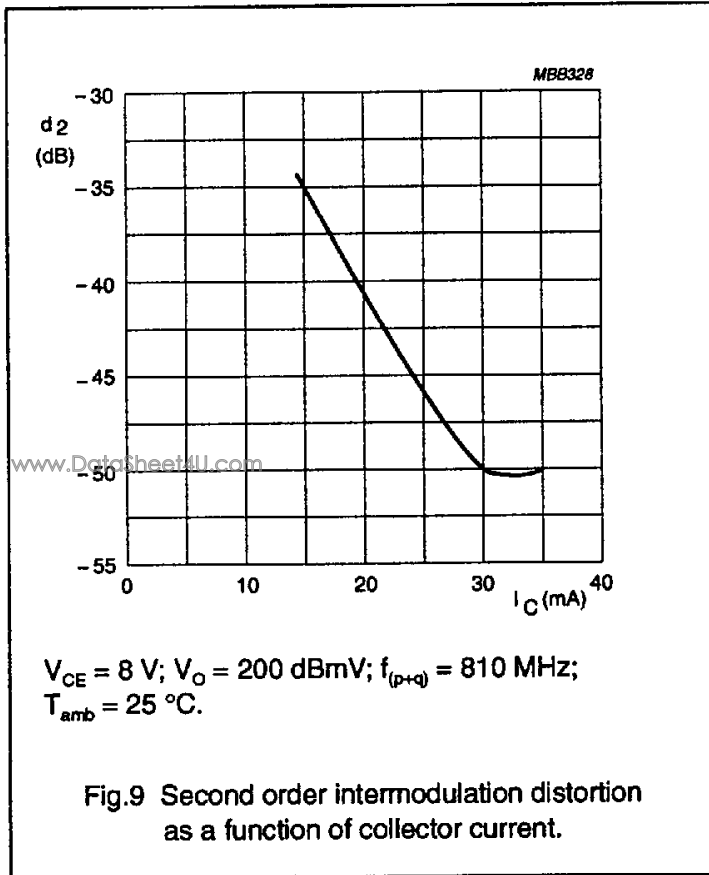

## NPN 6 GHz wideband transistor

BFG91A

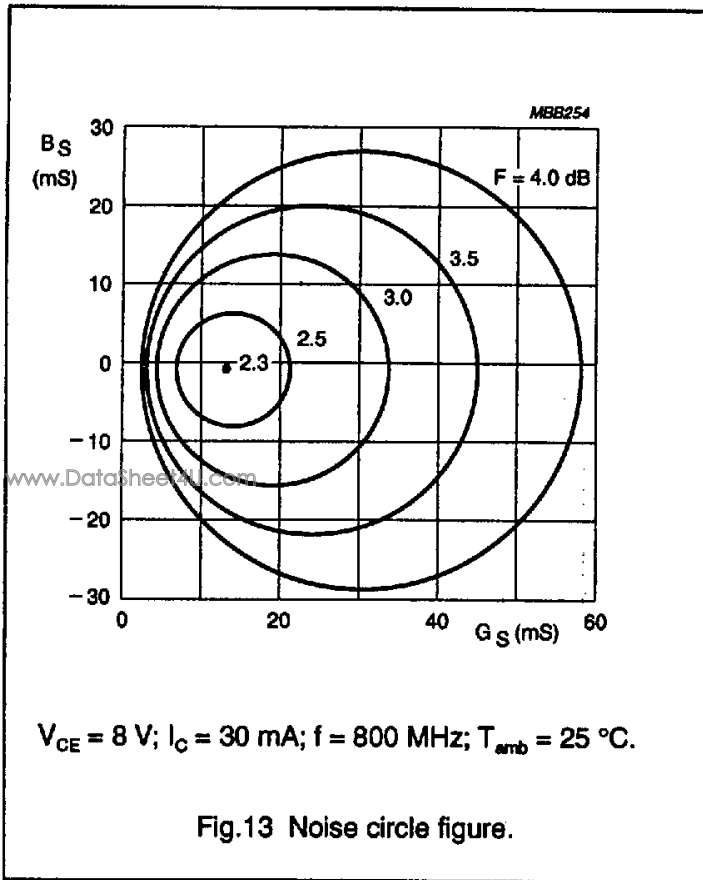

NPN 6 GHz wideband transistor

BFG91A

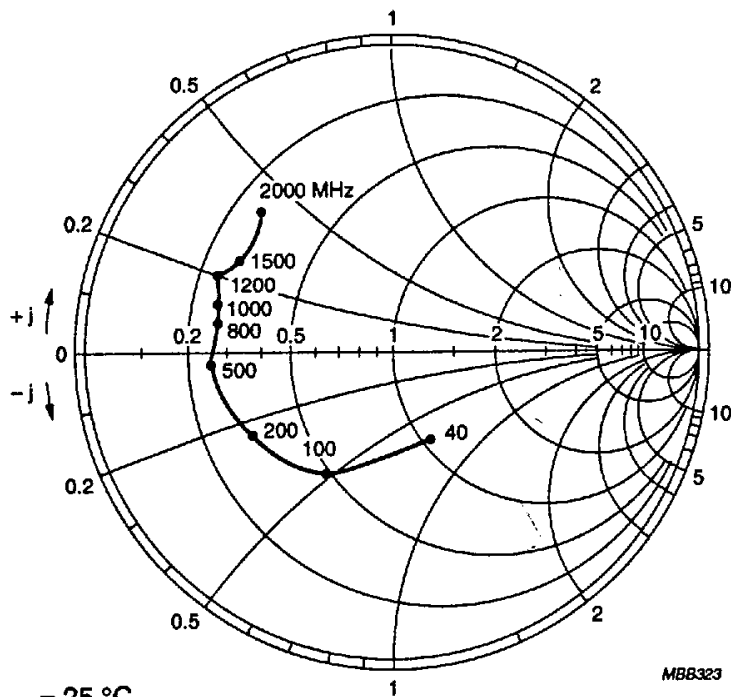

$I_C = 30 \text{ mA}; V_{CE} = 8 \text{ V}; T_{amb} = 25 \text{ }^\circ\text{C}.$

Fig.14 Common emitter input reflection coefficient ( $S_{11}$ ).

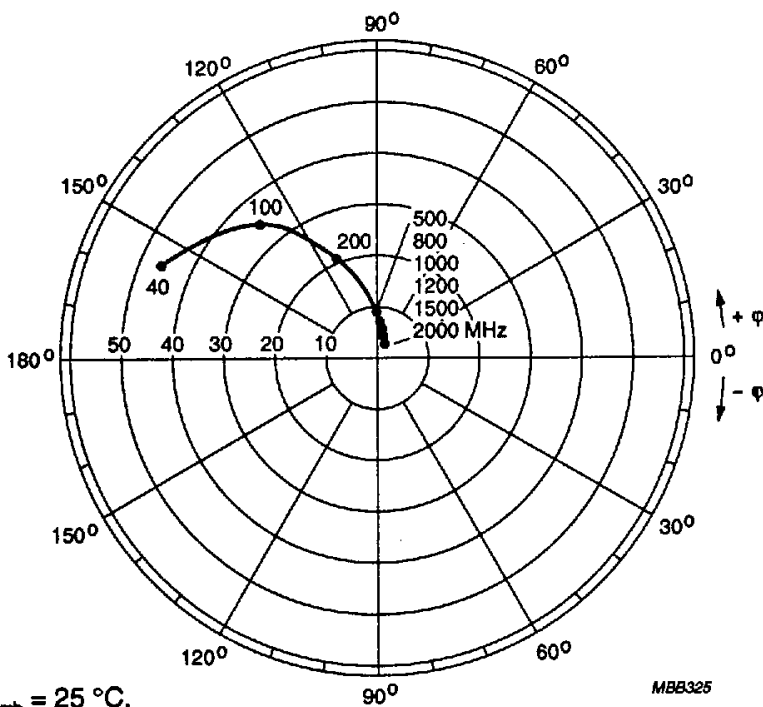

$I_C = 30 \text{ mA}; V_{CE} = 8 \text{ V}; T_{amb} = 25 \text{ }^\circ\text{C}.$

Fig.15 Common emitter forward transmission coefficient ( $S_{21}$ ).



NPN 6 GHz wideband transistor

BFG91A

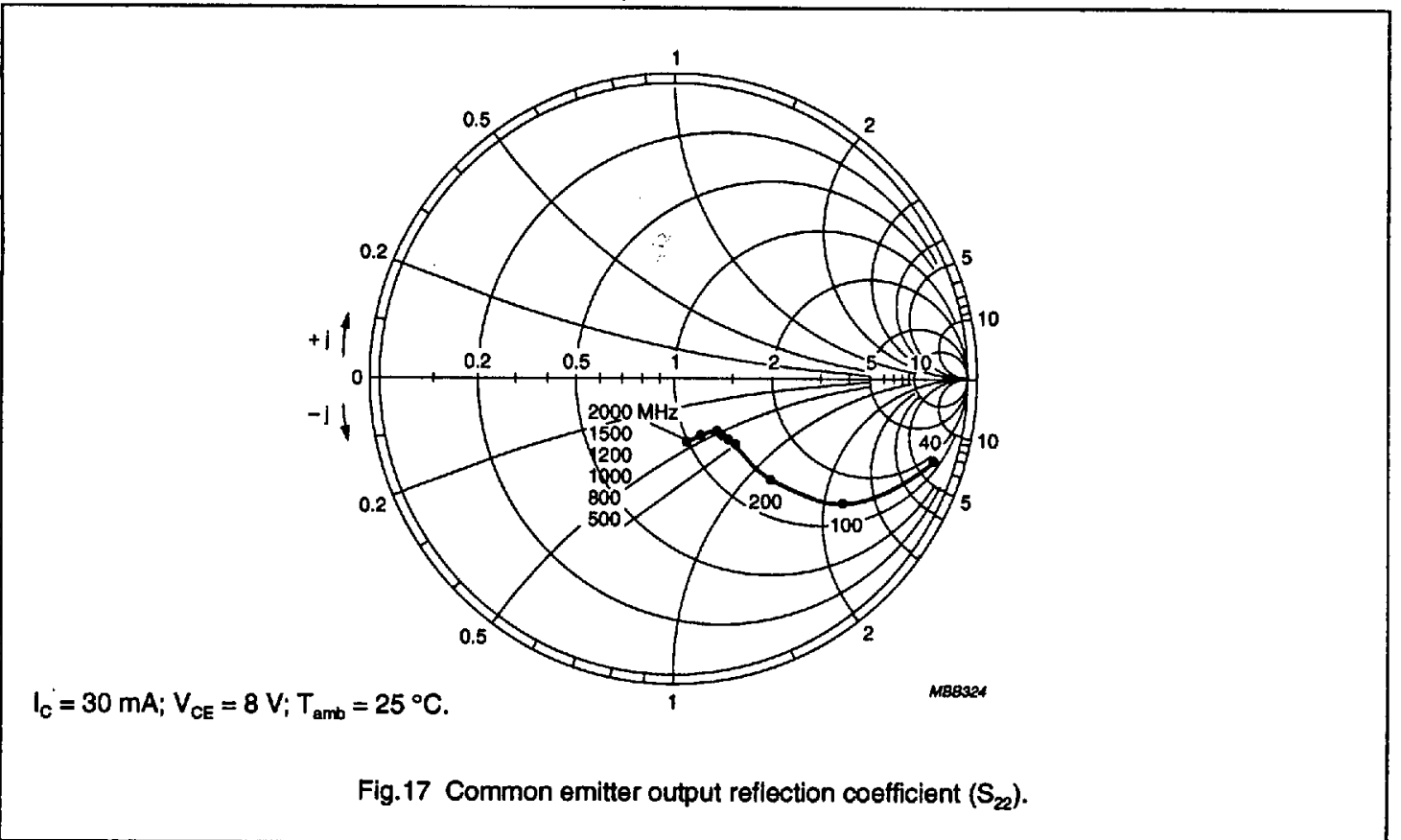
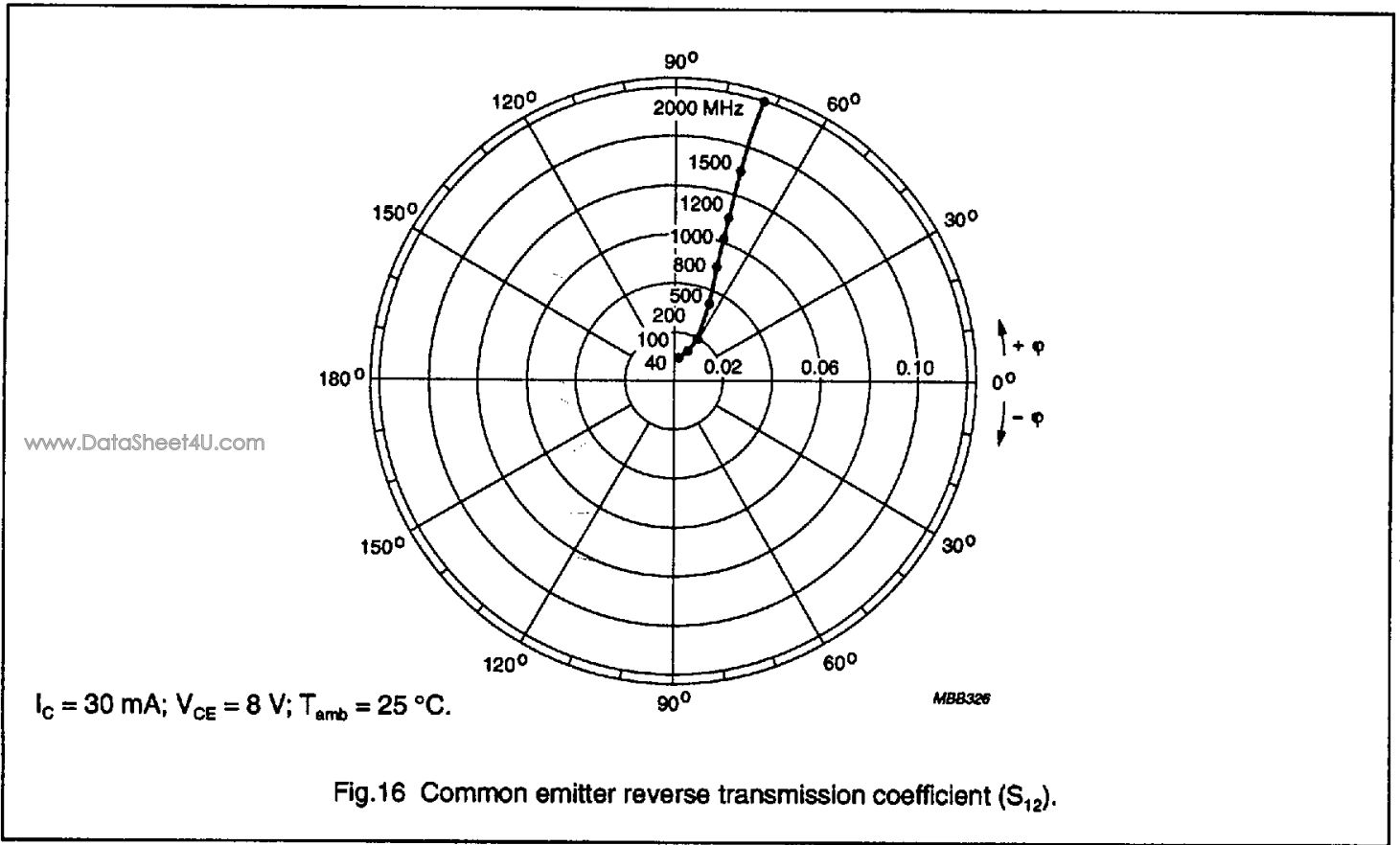

NPN 6 GHz wideband transistor

BFG91A

Table 1 Common emitter scattering parameters,  $I_C = 10 \text{ mA}$ ;  $V_{CE} = 8 \text{ V}$

f (MHz)	S <sub>11</sub>		S <sub>21</sub>		S <sub>12</sub>		S <sub>22</sub>		G <sub>UM</sub> (dB)
	MAG. (RAT)	ANG. (DEG)	MAG. (RAT)	ANG. (DEG)	MAG. (RAT)	ANG. (DEG)	MAG. (RAT)	ANG. (DEG)	
40	0.687	-29.3	25.578	163.6	0.009	84.2	0.960	-10.0	42.0
100	0.652	-66.0	21.764	143.8	0.021	63.3	0.847	-21.5	34.6
200	0.623	-106.0	15.792	123.8	0.030	48.9	0.665	-30.4	28.6
300	0.614	-129.5	11.802	111.9	0.035	42.7	0.553	-32.6	25.1
400	0.608	-142.9	9.275	104.4	0.038	41.5	0.489	-32.6	22.5
500	0.615	-152.2	7.658	99.2	0.041	41.2	0.453	-32.2	20.7
600	0.612	-159.2	6.491	94.9	0.044	44.2	0.429	-31.6	19.2
700	0.612	-164.5	5.641	91.4	0.045	45.5	0.412	-31.4	17.9
800	0.609	-169.4	4.996	88.1	0.049	46.7	0.402	-31.1	16.8
900	0.601	-173.5	4.461	85.3	0.051	48.4	0.393	-31.4	15.7
1000	0.606	-177.4	4.034	82.7	0.054	50.9	0.386	-31.6	14.8
1200	0.606	176.1	3.377	78.1	0.060	52.1	0.374	-32.7	13.2
1400	0.605	170.3	2.914	73.8	0.065	53.5	0.367	-34.5	11.9
1600	0.605	167.0	2.571	69.4	0.071	56.3	0.366	-36.5	10.8
1800	0.596	162.0	2.290	65.8	0.079	56.7	0.360	-38.3	9.7
2000	0.599	157.2	2.074	62.5	0.084	59.3	0.350	-40.1	8.8

Table 2 Common emitter scattering parameters,  $I_C = 30 \text{ mA}$ ;  $V_{CE} = 8 \text{ V}$

f (MHz)	S <sub>11</sub>		S <sub>21</sub>		S <sub>12</sub>		S <sub>22</sub>		G <sub>UM</sub> (dB)
	MAG. (RAT)	ANG. (DEG)	MAG. (RAT)	ANG. (DEG)	MAG. (RAT)	ANG. (DEG)	MAG. (RAT)	ANG. (DEG)	
40	0.475	-48.9	47.699	157.1	0.008	83.2	0.910	-18.1	42.3
100	0.507	-97.9	36.132	133.1	0.016	60.1	0.707	-35.9	35.4
200	0.545	-134.2	23.140	113.8	0.022	52.8	0.476	-46.7	29.9
300	0.568	-151.6	16.353	104.0	0.025	52.4	0.364	-48.9	26.6
400	0.574	-160.6	12.551	97.9	0.029	53.3	0.305	-48.5	24.1
500	0.580	-166.3	10.211	93.8	0.033	56.7	0.274	-47.6	22.3
600	0.582	-171.1	8.574	90.3	0.038	60.8	0.254	-46.5	20.8
700	0.584	-174.8	7.407	87.4	0.041	62.0	0.240	-46.3	19.5
800	0.578	-178.0	6.532	84.8	0.047	63.4	0.232	-45.5	18.3
900	0.580	178.8	5.822	82.4	0.052	64.1	0.226	-45.5	17.3
1000	0.584	175.8	5.263	80.3	0.057	66.1	0.221	-45.6	16.4
1200	0.587	170.4	4.393	76.4	0.065	65.8	0.213	-47.4	14.9
1400	0.586	166.3	3.775	72.7	0.074	67.1	0.210	-49.7	13.6
1600	0.588	163.1	3.335	68.7	0.083	66.6	0.212	-51.6	12.5
1800	0.580	159.6	2.974	65.4	0.093	66.3	0.210	-54.4	11.4
2000	0.585	154.4	2.700	62.3	0.102	66.7	0.202	-56.7	10.6