

PNP 5 GHz wideband transistor

BFQ23

N AMER PHILIPS/DISCRETE

69E D

DESCRIPTION

PNP transistor in a plastic SOT37 envelope, primarily intended for use in UHF and microwave amplifiers, such as in aerial amplifiers, radar systems, oscilloscopes, spectrum analyzers, etc.

The transistor features low intermodulation distortion and high power gain. It also has excellent wideband properties due to its very high transition frequency, and low noise up to high frequencies.

NPN complement is BFR91A.

PINNING

PIN	DESCRIPTION
1	base
2	emitter
3	collector

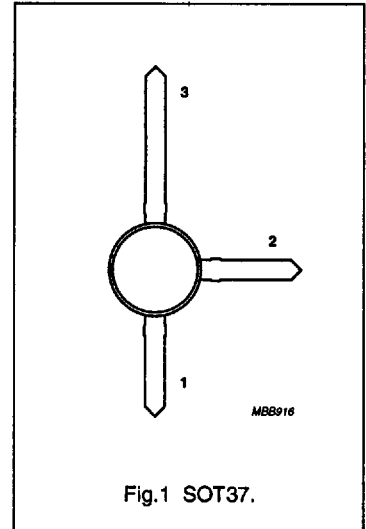

Fig.1 SOT37.

QUICK REFERENCE DATA

SYMBOL	PARAMETER	CONDITIONS	TYP.	MAX.	UNIT
V_{CE0}	collector-emitter voltage	open base	-	-12	V
I_C	DC collector current		-	-35	mA
P_{tot}	total power dissipation	up to $T_s = 158\text{ °C}$ (note 1)	-	250	mW
f_T	transition frequency	$I_C = -30\text{ mA}$; $V_{CE} = -5\text{ V}$; $f = 500\text{ MHz}$; $T_j = 25\text{ °C}$	5	-	GHz
C_{re}	feedback capacitance	$I_C = 0$; $V_{CE} = -10\text{ V}$; $f = 1\text{ MHz}$	0.8	-	pF
F	noise figure	$I_C = -2\text{ mA}$; $V_{CE} = -5\text{ V}$; $Z_S = \text{opt.}$; $f = 500\text{ MHz}$; $T_{amb} = 25\text{ °C}$	2.4	-	dB

Note

1. T_s is the temperature at the soldering point of the collector lead.

PNP 5 GHz wideband transistor

BFQ23

N AMER PHILIPS/DISCRETE

69E D

LIMITING VALUES

In accordance with the Absolute Maximum System (IEC 134).

SYMBOL	PARAMETER	CONDITIONS	MIN.	MAX.	UNIT
V_{CBO}	collector-base voltage	open emitter	-	-15	V
V_{CEO}	collector-emitter voltage	open base	-	-12	V
V_{EBO}	emitter-base voltage	open collector	-	-2	V
I_C	DC collector current		-	-35	mA
I_{CM}	peak collector current	$f > 1$ MHz	-	-50	mA
P_{tot}	total power dissipation	up to $T_s = 158$ °C (note 1)	-	250	mW
T_{stg}	storage temperature		-65	150	°C
T_j	junction temperature		-	175	°C

THERMAL RESISTANCE

SYMBOL	PARAMETER	CONDITIONS	THERMAL RESISTANCE
$R_{th\ j-s}$	thermal resistance from junction to soldering point	up to $T_s = 158$ °C (note 1)	65 K/W

Note

- T_s is the temperature at the soldering point of the collector lead.

CHARACTERISTICS

 $T_j = 25$ °C unless otherwise specified.

SYMBOL	PARAMETER	CONDITIONS	MIN.	TYP.	MAX.	UNIT
I_{CBO}	collector cut-off current	$I_E = 0$; $V_{CB} = -5$ V	-	-	-50	nA
h_{FE}	DC current gain	$I_C = -30$ mA; $V_{CE} = -5$ V	20	40	-	
C_c	collector capacitance	$I_E = I_B = 0$; $V_{CB} = -10$ V; $f = 1$ MHz	-	1.2	-	pF
C_e	emitter capacitance	$I_C = I_C = 0$; $V_{EB} = -0.5$ V; $f = 1$ MHz	-	1.8	-	pF
C_{re}	feedback capacitance	$I_C = 0$; $V_{CE} = -10$ V; $f = 1$ MHz	-	0.8	-	pF
f_T	transition frequency	$I_C = -30$ mA; $V_{CE} = -5$ V; $f = 500$ MHz	-	5	-	GHz
G_{UM}	maximum unilateral power gain (note 1)	$I_C = -30$ mA; $V_{CE} = -5$ V; $f = 500$ MHz; $T_{amb} = 25$ °C	-	15	-	dB
F	noise figure	$I_C = -2$ mA; $V_{CE} = -5$ V; $Z_S = \text{opt.}$; $f = 500$ MHz; $T_{amb} = 25$ °C	-	2.4	-	dB
V_O	output voltage	note 2	-	300	-	mV

Notes

- G_{UM} is the maximum unilateral power gain, assuming S_{12} is zero and $G_{UM} = 10 \log \frac{|S_{21}|^2}{(1 - |S_{11}|^2)(1 - |S_{22}|^2)}$ dB.
- $d_{im} = -60$ dB; $I_C = -30$ mA; $V_{CE} = -5$ V; $R_L = 75$ Ω ; $T_{amb} = 25$ °C
 $V_p = V_O$ at $d_{im} = -60$ dB; $f_p = 495.25$ MHz;
 $V_q = V_O - 6$ dB; $f_q = 505.25$ MHz;
 $V_r = V_O - 6$ dB; $f_r = 505.25$ MHz;
measured at $f_{(p+q-r)} = 495.25$ MHz.

PNP 5 GHz wideband transistor

BFQ23

N AMER PHILIPS/DISCRETE

69E D

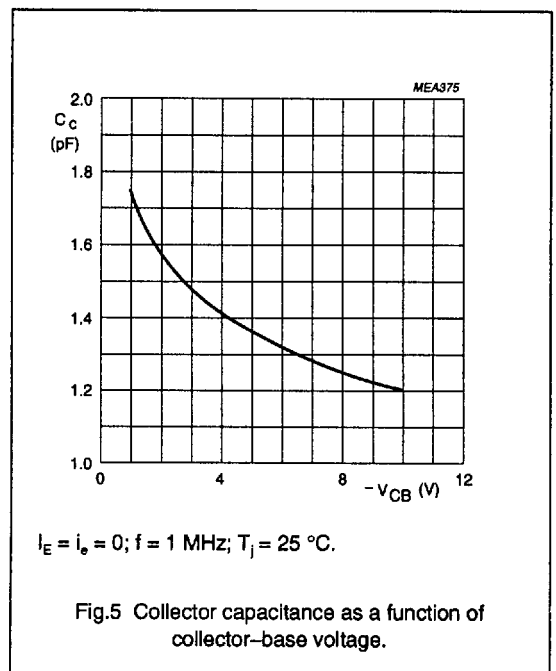
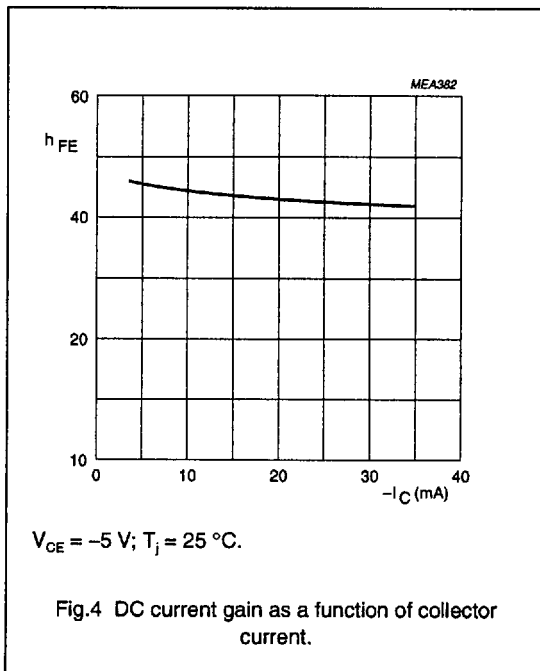
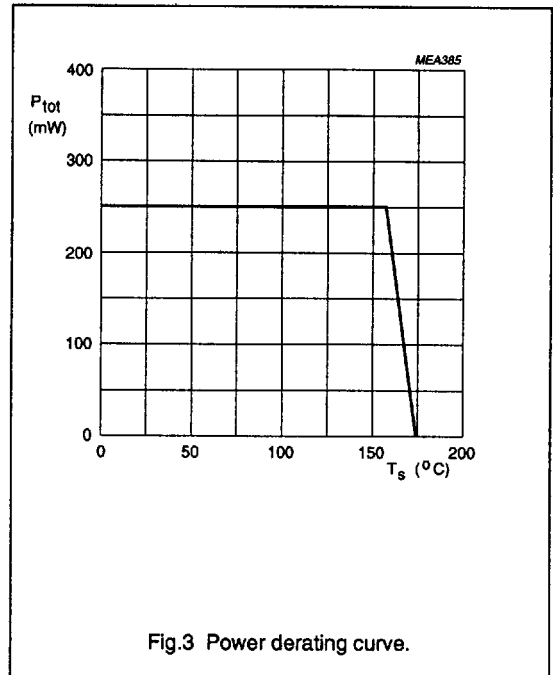
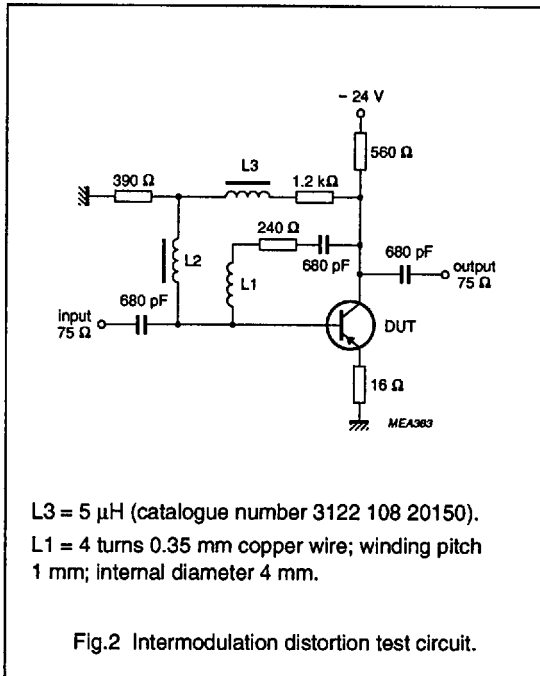

PNP 5 GHz wideband transistor

BFQ23

N AMER PHILIPS/DISCRETE

69E D

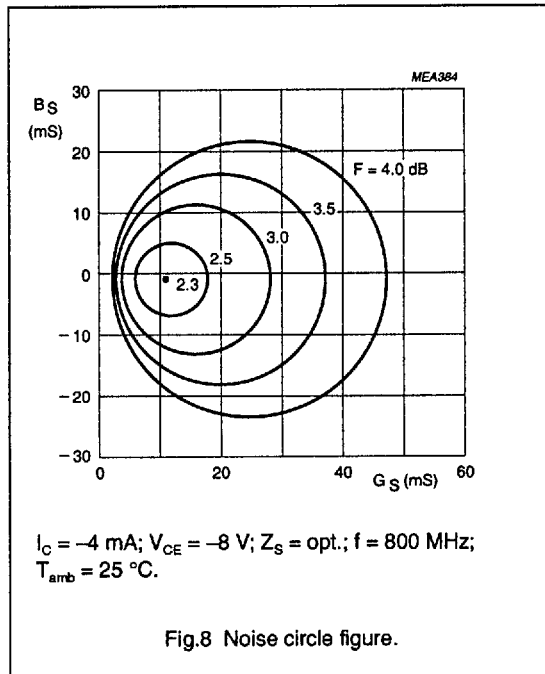
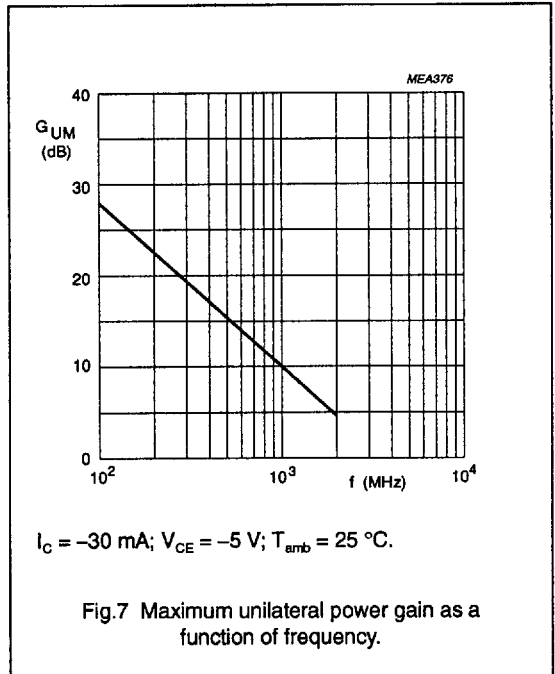
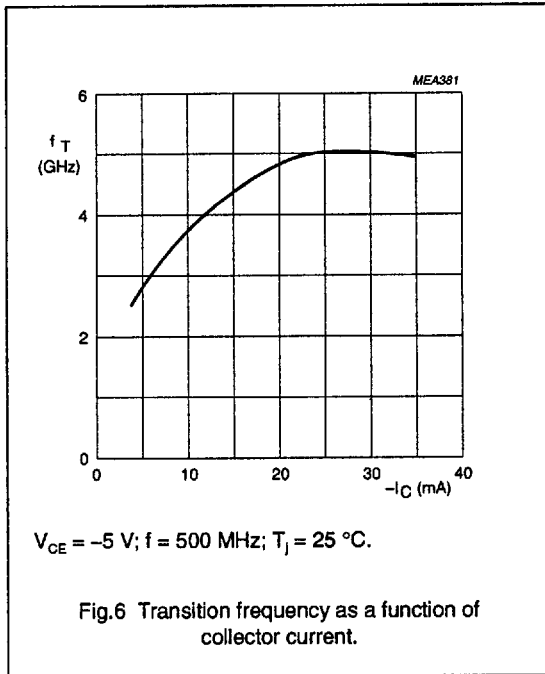

PNP 5 GHz wideband transistor

BFQ23

N AMER PHILIPS/DISCRETE

69E D

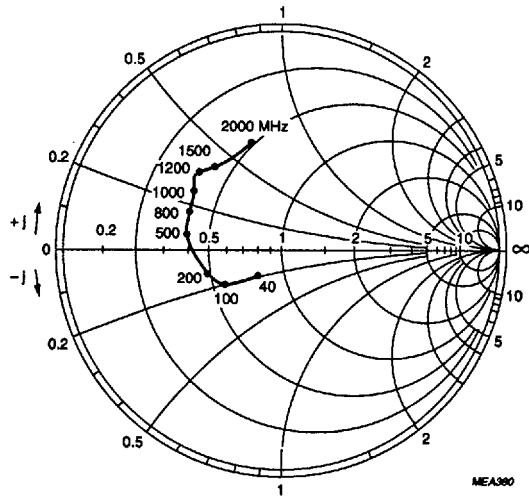

$I_C = -30 \text{ mA}; V_{CE} = -5 \text{ V}; T_{amb} = 25 \text{ }^\circ\text{C}.$

Fig.9 Common emitter input reflection coefficient (S_{11}).

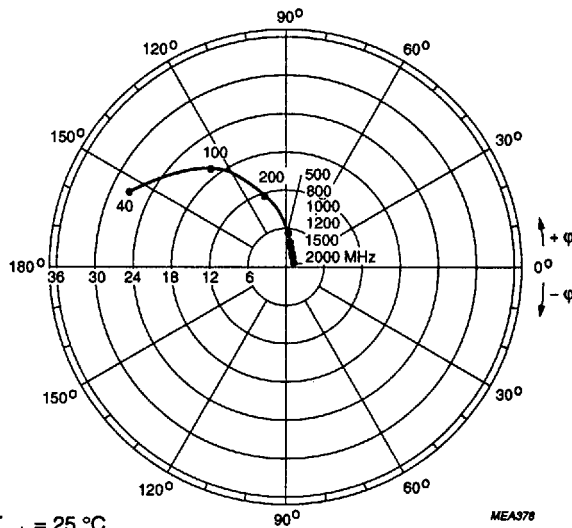

$I_C = -30 \text{ mA}; V_{CE} = -5 \text{ V}; T_{amb} = 25 \text{ }^\circ\text{C}.$

Fig.10 Common emitter forward transmission coefficient (S_{21}).

PNP 5 GHz wideband transistor

BFQ23

N AMER PHILIPS/DISCRETE

69E D

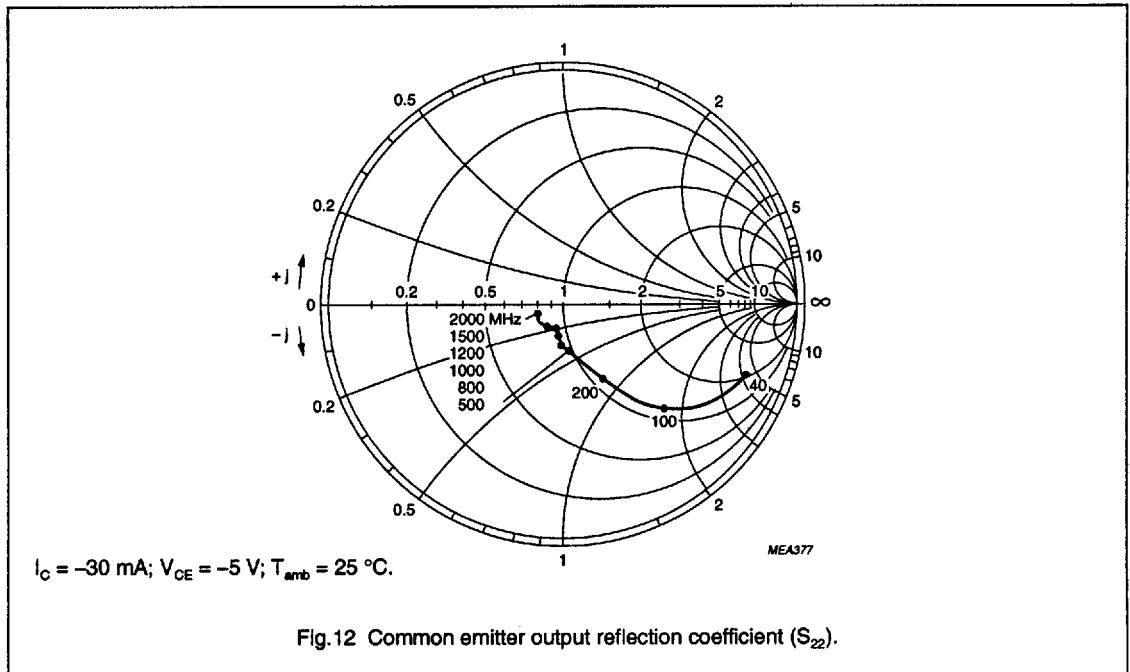
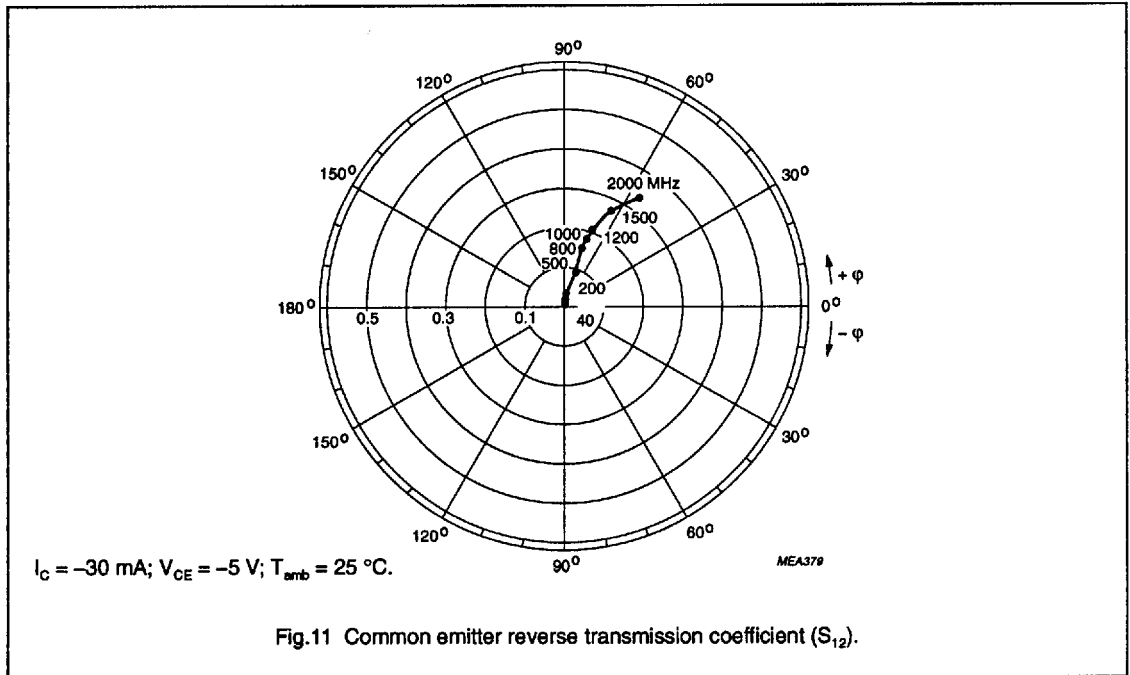

PNP 5 GHz wideband transistor

BFQ23

N AMER PHILIPS/DISCRETE

69E D

Table 1 Common emitter scattering parameters, $I_C = -10$ mA; $V_{CE} = -5$ V

f (MHz)	S ₁₁		S ₂₁		S ₁₂		S ₂₂		G _{UM} (dB)
	MAG. (RAT)	ANG. (DEG)	MAG. (RAT)	ANG. (DEG)	MAG. (RAT)	ANG. (DEG)	MAG. (RAT)	ANG. (DEG)	
40	0.398	-44.1	19.225	162.6	0.017	76.2	0.925	-17.9	34.8
100	0.484	-89.1	16.228	141.0	0.037	58.8	0.781	-40.6	29.5
200	0.573	-129.1	11.404	118.7	0.053	44.7	0.555	-65.1	24.5
300	0.617	-148.3	8.419	105.5	0.061	38.8	0.420	-80.6	21.4
400	0.639	-159.2	6.605	96.6	0.066	37.1	0.345	-91.7	19.2
500	0.650	-167.4	5.415	89.7	0.071	36.9	0.301	-100.1	17.5
600	0.657	-173.3	4.594	84.1	0.076	36.9	0.272	-106.1	16.0
700	0.657	-178.4	3.974	79.1	0.081	37.4	0.252	-111.1	14.7
800	0.658	177.3	3.523	74.9	0.086	38.0	0.235	-115.3	13.6
900	0.662	173.1	3.153	70.8	0.092	38.5	0.220	-119.0	12.7
1000	0.663	169.1	2.837	66.8	0.097	38.9	0.207	-123.4	11.8
1200	0.673	162.1	2.410	59.4	0.108	38.7	0.196	-134.0	10.4
1400	0.686	155.8	2.075	52.6	0.118	38.0	0.202	-144.1	9.3
1600	0.690	150.3	1.829	46.0	0.129	37.0	0.216	-149.3	8.3
1800	0.689	145.1	1.670	38.9	0.141	35.2	0.225	-152.4	7.5
2000	0.700	139.6	1.523	33.2	0.154	33.4	0.226	-157.6	6.8
2200	0.717	133.7	1.400	27.2	0.166	32.0	0.232	-165.3	6.3
2400	0.739	129.5	1.299	22.4	0.174	30.4	0.253	-173.4	6.0
2600	0.745	125.5	1.198	16.6	0.182	27.9	0.283	-178.2	5.4
2800	0.748	121.3	1.130	10.2	0.191	25.2	0.308	179.0	5.1
3000	0.750	115.9	1.069	5.2	0.202	22.8	0.317	175.3	4.6

PNP 5 GHz wideband transistor

BFQ23

N AMER PHILIPS/DISCRETE

69E D

Table 2 Common emitter scattering parameters, $I_C = -30$ mA; $V_{CE} = -5$ V

f (MHz)	S ₁₁		S ₂₁		S ₁₂		S ₂₂		G _{UM} (dB)
	MAG. (RAT)	ANG. (DEG)	MAG. (RAT)	ANG. (DEG)	MAG. (RAT)	ANG. (DEG)	MAG. (RAT)	ANG. (DEG)	
40	0.240	-119.3	27.300	157.9	0.012	71.9	0.847	-25.5	34.5
100	0.461	-138.7	21.121	133.3	0.023	57.3	0.661	-55.5	30.0
200	0.596	-158.6	13.535	111.9	0.033	50.2	0.446	-85.8	25.5
300	0.642	-168.6	9.634	100.4	0.039	49.2	0.345	-105.0	22.5
400	0.659	-174.7	7.423	92.7	0.046	51.2	0.296	-118.8	20.3
500	0.673	-179.8	6.028	86.6	0.052	51.9	0.270	-128.6	18.5
600	0.677	176.1	5.090	81.6	0.059	52.8	0.255	-135.7	17.1
700	0.677	172.6	4.395	76.9	0.066	53.3	0.242	-141.2	15.8
800	0.676	169.0	3.882	73.4	0.073	53.4	0.229	-146.2	14.7
900	0.682	166.0	3.468	69.3	0.080	53.4	0.219	-150.9	13.7
1000	0.684	163.0	3.113	65.9	0.087	53.2	0.212	-156.0	12.8
1200	0.700	156.9	2.637	59.2	0.101	51.9	0.212	-166.1	11.5
1400	0.711	151.5	2.261	52.9	0.113	50.1	0.225	-173.4	10.4
1600	0.714	147.0	1.983	46.4	0.127	47.8	0.234	-176.3	9.3
1800	0.713	141.9	1.800	39.9	0.141	44.9	0.238	-178.4	8.4
2000	0.722	136.4	1.648	34.1	0.155	42.0	0.238	177.0	7.8
2200	0.747	131.2	1.503	28.5	0.168	40.0	0.247	170.4	7.4
2400	0.766	126.7	1.401	24.1	0.178	37.6	0.270	165.0	7.1
2600	0.771	123.7	1.286	18.8	0.187	34.5	0.298	162.5	6.5
2800	0.781	119.0	1.222	12.8	0.196	31.2	0.314	161.2	6.3
3000	0.774	113.8	1.141	8.0	0.209	28.4	0.319	158.2	5.6