

PNP SILICON PLANAR TRANSISTOR

BFX30

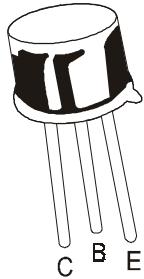

**TO-39
Metal Can Package**

INTENDED FOR SWITCHING APPLICATIONS.

ABSOLUTE MAXIMUM RATINGS (Ta=25°C unless specified otherwise)

DESCRIPTION	SYMBOL	VALUE	UNITS
Collector Emitter Voltage	V_{CEO}	65	V
Collector Base Voltage	V_{CBO}	65	V
Emitter Base Voltage	V_{EBO}	5.0	V
Collector Current Continuous	I_C	600	mA
Peak	I_{CM}	600	mA
Emitter Current (Peak Value)	I_{EM}	600	mA
Total Device Dissipation @ Ta=25°C	P_{tot}	600	mW
Operating And Storage Junction Temperature Range	T_j, T_{stg}	-65 to +200	°C

THERMAL RESISTANCE

Junction to Ambient	$R_{th(j-a)}$	300	K/W
---------------------	---------------	-----	-----

ELECTRICAL CHARACTERISTICS (Ta=25°C unless specified otherwise)

DESCRIPTION	SYMBOL	TEST CONDITION	VALUE		UNITS
			MIN	MAX	
Collector Cut off Current	I_{CBO}	$V_{CB}=65V, I_E=0$		500	nA
		$V_{CB}=50V, I_E=0$		50	nA
		$V_{CB}=50V, I_E=0, T_j=100^\circ C$		2.0	μA
Emitter Cut off Current	I_{EBO}	$V_{EB}=5V, I_C=0$		500	nA
		$V_{EB}=3V, I_C=0$		100	nA
DC Current Gain	h_{FE}	$I_C=1.0mA, V_{CE}=0.4V$	40		
		$I_C=10mA, V_{CE}=0.4V$	50	200	
		$I_C=50mA, V_{CE}=0.4V$	20		
		$I_C=150mA, V_{CE}=0.4V$	10		
Base Emitter Saturation Voltage	$V_{BE(Sat)}$	$I_C=30mA, I_B=1.0mA$	0.9		V
		$I_C=150mA, I_B=15mA$	1.3		V

PNP SILICON PLANAR TRANSISTOR

BFX30

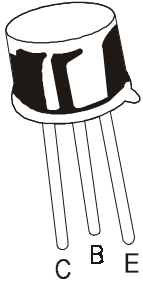

**TO-39
Metal Can Package**

ELECTRICAL CHARACTERISTICS (Ta=25° C unless specified otherwise)

DESCRIPTION	SYMBOL	TEST CONDITION	VALUE		UNITS
			MIN	MAX	
<u>SMALL SIGNAL CHARACTERISTICS</u>					
Collector Capacitance	C_{tc}	$V_{CB}=10V, I_E=I_C=0, f=1MHz$	typ.	6.0	pF
Emitter Capacitance	C_{te}	$V_{EB}=2.0V, I_C=, f=1MHz$	typ.	18	pF
<u>SWITCHING TIMES</u>					
Delay Time	t_d			15	ns
Rise Time	t_r			40	ns
Turn on time (td+ tr)	t_{on}	$I_C=100mA, I_{Bon}=I_{Boff}=10mA$		50	ns
Storage time	t_s			250	ns
Fall time	t_f			50	ns
Turn off time (ts+tf)	t_{off}			290	ns

TO-39 Metal Can Package

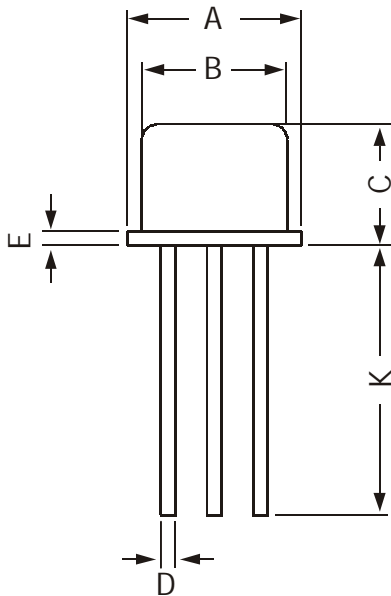

All dimensions are in mm

DIM	MIN	MAX
A	8.50	9.39
B	7.74	8.50
C	6.09	6.60
D	0.40	0.53
E	—	0.88
F	2.41	2.66
G	4.82	5.33
H	0.71	0.86
J	0.73	1.02
K	12.70	—
L	42 DEG	48 DEG

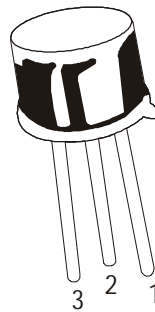
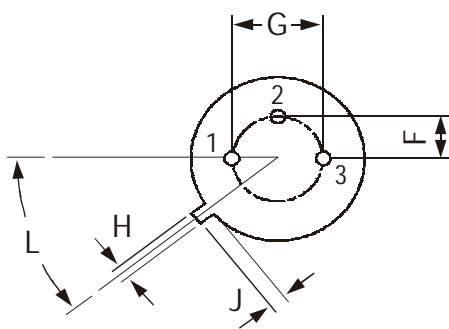

PIN CONFIGURATION

- 1. EMITTER
- 2. BASE
- 3. COLLECTOR

Packing Detail

PACKAGE	STANDARD PACK		INNER CARTON BOX		OUTER CARTON BOX		
	Details	Net Weight/Qty	Size	Qty	Size	Qty	Gr Wt
TO-39	500 pcs/polybag	540 gm/500 pcs	3" x 7.5" x 7.5"	20K	17" x 15" x 13.5"	32K	40 kgs

Disclaimer

The product information and the selection guides facilitate selection of the CDIL's Discrete Semiconductor Device(s) best suited for application in your product(s) as per your requirement. It is recommended that you completely review our Data Sheet(s) so as to confirm that the Device(s) meet functionality parameters for your application. The information furnished in the Data Sheet and on the CDIL Web Site/CD is believed to be accurate and reliable. CDIL however, does not assume responsibility for inaccuracies or incomplete information. Furthermore, CDIL does not assume liability whatsoever, arising out of the application or use of any CDIL product; neither does it convey any license under its patent rights nor rights of others. These products are not designed for use in life saving/support appliances or systems. CDIL customers selling these products (either as individual Discrete Semiconductor Devices or incorporated in their end products), in any life saving/support appliances or systems or applications do so at their own risk and CDIL will not be responsible for any damages resulting from such sale(s).

CDIL strives for continuous improvement and reserves the right to change the specifications of its products without prior notice.



CDIL is a registered Trademark of

Continental Device India Limited

C-120 Naraina Industrial Area, New Delhi 110 028, India.

Telephone + 91-11-579 6150 Fax + 91-11-579 9569, 579 5290

e-mail sales@cdil.com www.cdil.com