



LCD MODULE SPECIFICATION

MODEL NO.

BG12864EFPHn

FOR MESSRS:

ON DATE OF:

APPROVED BY:



C O N T E N T S

1. Numbering System
2. General Specification
3. Absolute Maximum Ratings
4. Electrical Characteristics
5. Optical Characteristics
6. Interface Description
7. Timing characteristics
8. Power supply for LCD Module and LCD operating voltage adjustment
9. Backlight information
10. Display control instruction
11. Quality Assurance
12. Reliability
13. Outline Dimension



1. Numbering System

<u>B</u>	<u>G</u>	<u>12864</u>	<u>E</u>	<u>F</u>	<u>P</u>	<u>H</u>	<u>-</u>	<u>H</u>	<u>n</u>
0	1	2	3	4	5	6	7	8	9

0	Brand	Bolymin	
1	Module Type	C= character type G= graphic type P= TAB/TCP type	O= COG type F= COF type
2	Format	2002=20 characters, 4 lines 12232= 122 x 32 dots	
3	Version No.	A type	
4	LCD Color	G=STN/gray Y=STN/yellow-green C=color STN	B=STN/blue F=FSTN T=TN
5	LCD Type	R=positive/reflective P=positive/transflective	M=positive/transmissive N=negative/transmissive
6	Backlight type/color	L=LED array/ yellow-green H=LED edge/white R=LED array/red G=LED edge/yellow-green	D=LED edge/blue E=EL/white B=EL/blue C=CCFL/white
7	CGRAM Font (applied only on character type)	J=English/Japanese Font E=English/European Font	C=English/Cyrillic Font H=English/Hebrew Font
8	View Angle/ Operating Temperature	B=Bottom/Normal Temperature H=Bottom/Wide Temperature U=Bottom/Ultra wide Temperature	T=Top/Normal Temperature W=Top/Wide Temperature C=9H/Normal Temperature
9	Special Code	3=3 volt logic power supply n=negative voltage for LCD c=cable/connector xxx=to be assigned on data sheet	t=temperature compensation for LCD p=touch panel



2. General Specification

(1) Mechanical Dimension

Item	Standard Value	Unit
Number of dots	128x64	dots
Module dimension (L*W*H)	75.0 x 52.7 x 8.4	mm
View area	60.0(W)x32.6(H)	mm
Active area	56.02(W)x27.5(H)	mm
Dot size	0.41(W)x0.41(H)	mm
Dot pitch	0.43(W)x0.43(H)	mm

(2) Controller IC: KS107 / KS108

(3) Temperature Range

	Wide
Operating	-20 ~ +70°C
Storage	-30 ~ +80°C

3. Absolute Maximum Ratings

Item	Symbol	Min	Typ	Max	Unit
Operating Temperature	T _{OP}	-20	—	+70	°C
Storage Temperature	T _{ST}	-30	—	+80	°C
Input Voltage	V _I	0	—	V _{CC}	V
Supply Voltage For Logic	V _{CC}	0	—	67	V
Supply Voltage For LCD	V _{CC} -V _{LCD}	0	—	16.7	V
Supply Voltage For LCD	V _{OUT}	—	—	-10	V



4. Electrical Characteristics

Item	Symbol	Condition	Min.	Typ.	Max.	Unit
Supply Voltage For Logic	$V_{DD}-V_{SS}$	—	4.5	5.0	5.5	V
Supply Voltage For LCD	$V_{DD}-V_0$	Ta=-20°C	—	9.8	—	V
		Ta=25°C	—	8.5	—	V
		Ta=+70°C	—	7.5	—	V
Input High Vol	V_{IH}	—	$0.7V_{DD}$	—	V_{DD}	V
Input Low Vol	V_{IL}	—	0	—	$0.3V_{DD}$	V
Output High Vol	V_{OH}	—	2.4	—	—	V
Output Low Vol.	V_{OL}	—	—	—	0.4	V
Supply Current	I_{DD}	—	—	6.0	—	mA

5. Optical Characteristics

a. FSTN

Item	Symbol	Condition	Min.	Typ.	Max.	Unit
View Angle	(V) θ	$CR \geq 24$	10		60	deg
	(H) φ	$CR \geq 24$	-45		45	deg
Contrast Ratio	CR	—		24		—
Response Time 25°C	T rise	—		100	150	ms
	T fall	—		150	200	ms



5.1 Definitions

■ View Angles

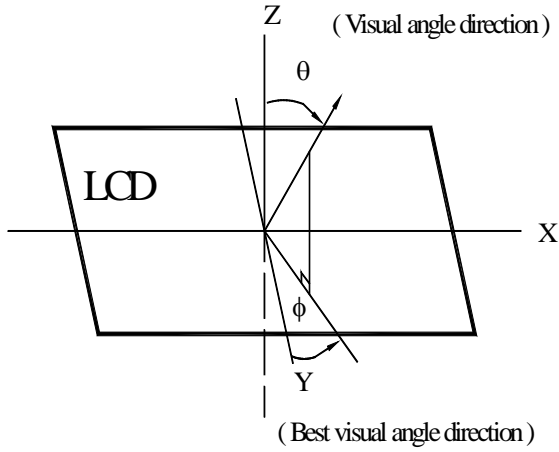

■ Contrast Ratio

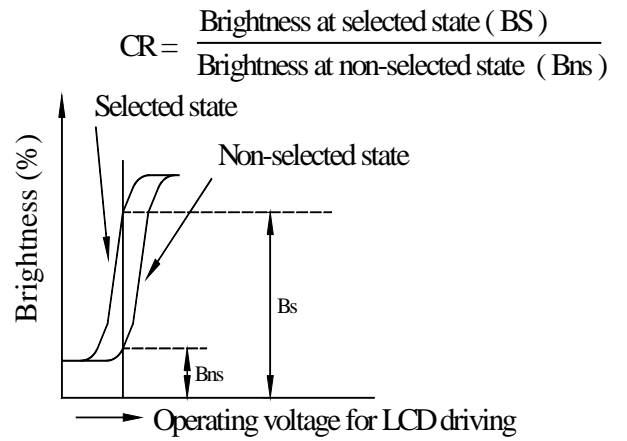

■ Response time

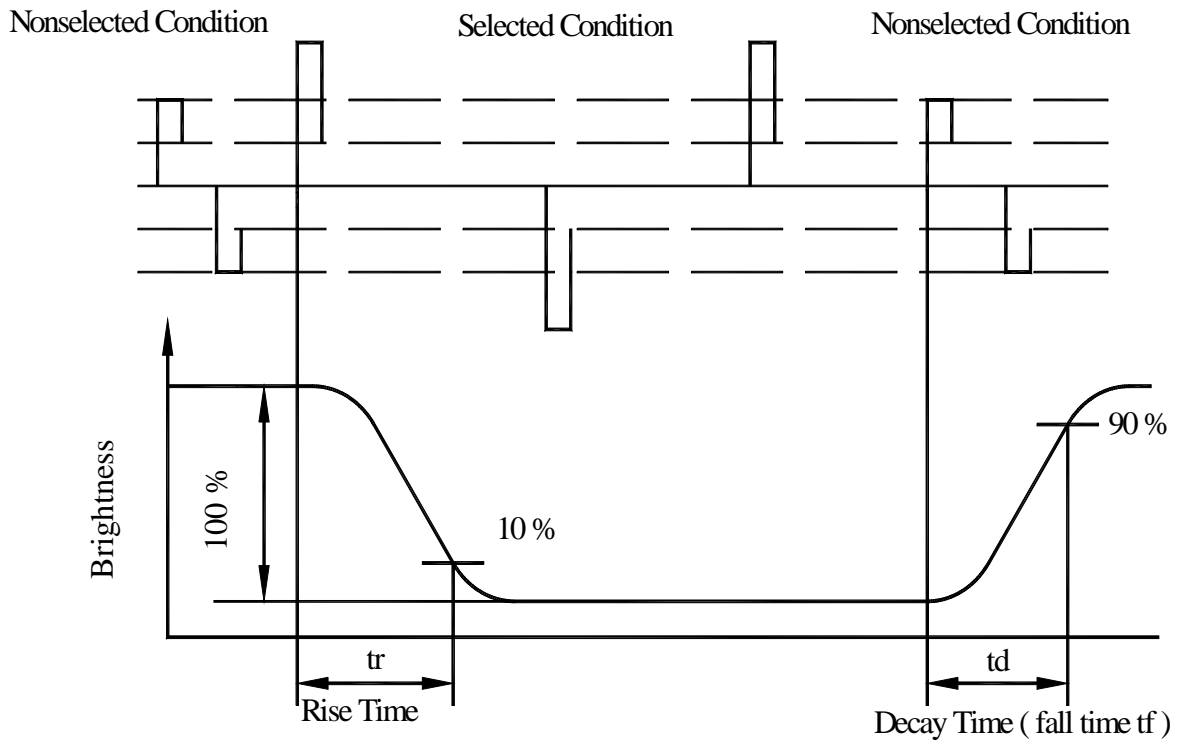



6. Interface Pin Function

Pin No.	Symbol	Level	Description
1	V _{dd}	5.0V	Supply voltage for logic (option +3V)
2	GND	0V	Ground
3	V _O	(Variable)	Operating voltage for LCD
4	DB0	H/L	Data bus line
5	DB1	H/L	Data bus line
6	DB2	H/L	Data bus line
7	DB3	H/L	Data bus line
8	DB4	H/L	Data bus line
9	DB5	H/L	Data bus line
10	DB6	H/L	Data bus line
11	DB7	H/L	Data bus line
12	/CS1	L	Chip Select for IC1
13	/CS2	L	Chip Select for IC2
14	/RST	L	Reset signal
15	R/W	H/L	H=Read mode , L=Write mode
16	D/I	H/L	H=Data register , L=Instruction register
17	E	H/L	Enable signal
18	V _{ee}		Negative Voltage output -4.8V
19	A	—	Power supply for B/L (+)
20	K	—	Power supply for B/L (GND)



7. Timing Characteristics

MPU Interface

Characteristic	Symbol	Min	Typ	Max	Unit
E cycle	tcyc	1000	—	—	ns
E high level width	twhE	450	—	—	ns
E low level width	twlE	450	—	—	ns
E rise time	tr	—	—	25	ns
E fall time	tf	—	—	25	ns
Address set-up time	tas	140	—	—	ns
Address hold time	tah	10	—	—	ns
Data set-up time	tdsw	200	—	—	ns
Data delay time	tddr	—	—	320	ns
Data hold time (write)	tdhw	10	—	—	ns
Data hold time (read)	tdhr	20	—	—	ns

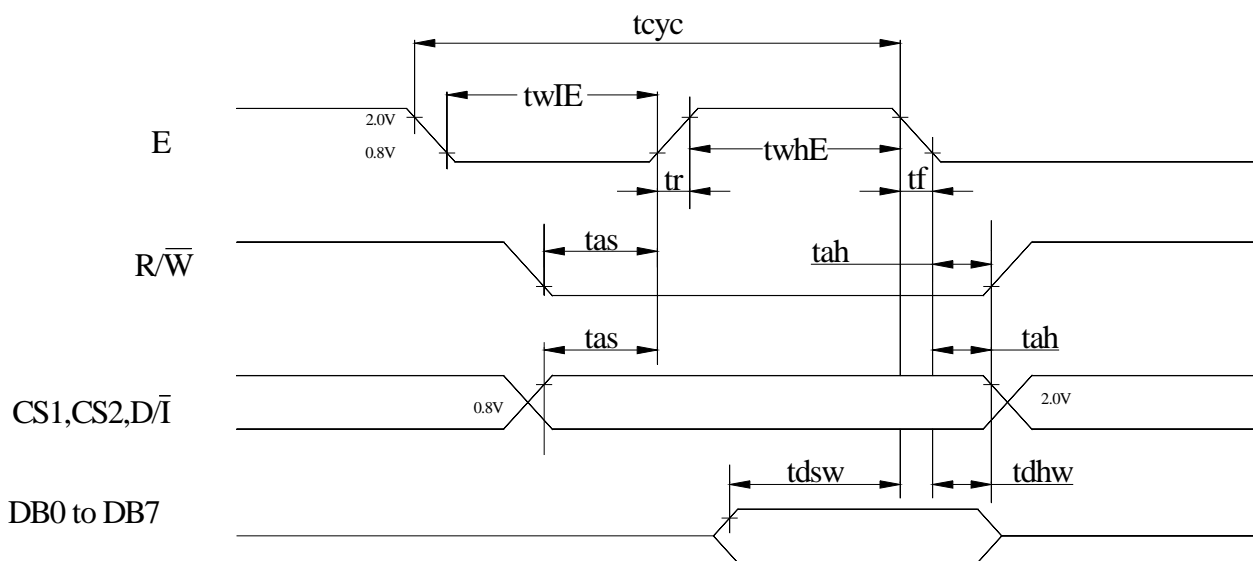

MPU Write Timing

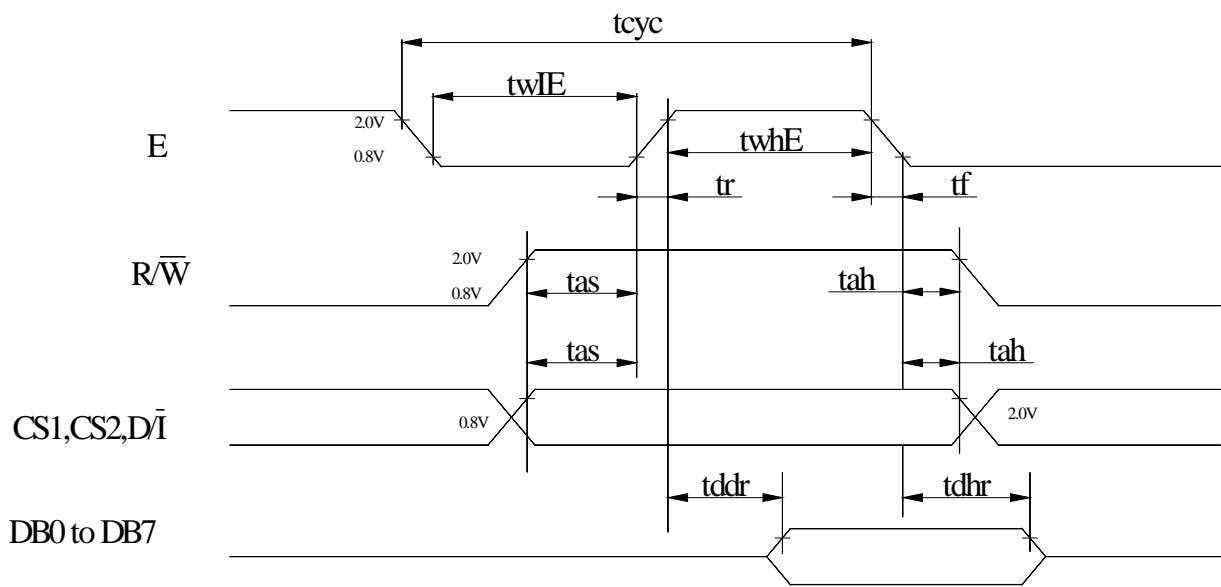

MPU Read Timing



8. Power Supply for LCD Module and LCD Operating Voltage a Adjustment

* LCM operating on " DC 5V " input with built-in negative voltage

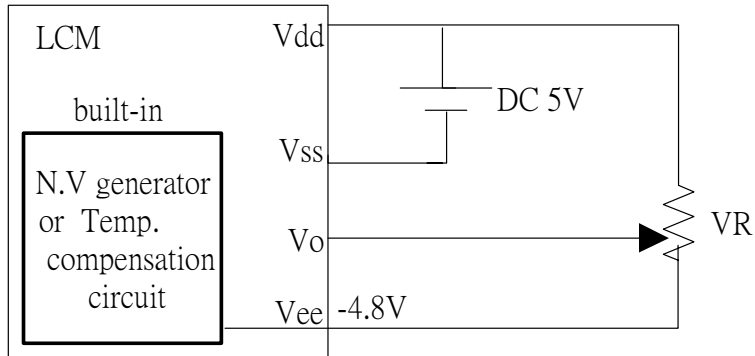



9. Backlight Information

9.1 Specification

(1) LED white / blue

Parameter	Symbol	Min	Typ	Max	Unit	Test Condition
Supply Current	I _{LED}		30	45	mA	V=3.2V
Supply Voltage	V		3.2	3.3	V	—
Reverse Voltage	V _R	—	—	8	V	—
Luminous Intensity	I _V	30	40	—	cd/m ²	I _{LED} =30mA
Wave Length	λ _p	—		—	nm	I _{LED} =30mA
Life Time		—	20000	—	Hr.	V ≤ 3.3V
Color	White					

9.2 Backlight driving methods

a. LED edge/yellow-green B/L drive from pin19 (LED+) pin20 (LED-)

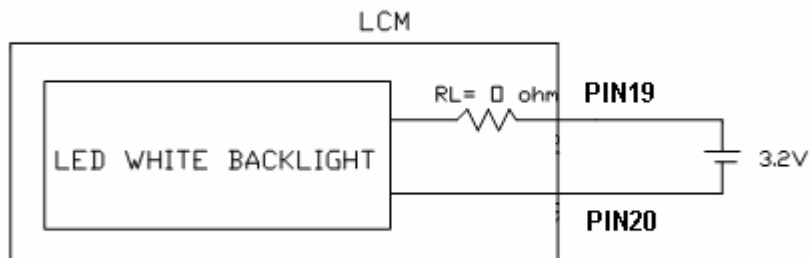



10. Display Control Instruction

The display control instructions control the internal state of the KS0108B. Instruction is received from MPU to KS0108B for the display control. The following table shows various instructions.

Instruction	D/I	R/W	DB7	DB6	DB5	DB4	DB3	DB2	DB1	DB0	Function	
Display ON/OFF	0	0	0	0	1	1	1	1	1	0/1	Controls the display on or off. Internal status and display RAM data are not affected. 0:OFF, 1:ON	
Set Address	0	0	0	1	Y address (0~63)						Sets the Y address in the Y address counter.	
Set Page (X address)	0	0	1	0	1	1	1	Page (0 ~7)			Sets the X address at the X address register.	
Display Start Line	0	0	1	1	Display start line(0~63)						Indicates the display data RAM displayed at the top of the screen.	
Status Read	0	1	B U S Y	0	ON/ OFF	R E S E T	0	0	0	0	Read status. BUSY 0:Ready 1:In operation ON/OFF 0:Display ON 1:Display OFF RESET 0:Normal 1:Reset	
Write Display Data	1	0	Display Data									Writes data (DB0:7) into display data RAM. After writing instruction, Y address is increased by 1 automatically.
Read Display Data	1	1	Display Data									Reads data (DB0:7) from display data RAM to the data bus.



10.1 Detailed Explanation

Display On/Off

R/W	D/I	DB7	DB6	DB5	DB4	DB3	DB2	DB1	DB0
0	0	0	0	1	1	1	1	1	D

The display data appears when D is and disappears when D is 0. Though the data is not on the screen with D = 0, it remains in the display data RAM. Therefore, you can make it appear by changing D = 0 into D = 1.

Display Start Line

R/W	D/I	DB7	DB6	DB5	DB4	DB3	DB2	DB1	DB0
0	0	1	1	A	A	A	A	A	A

Z address AAAAAA (binary) of the display data RAM is set in the display start line register and displayed at the top of the screen. Figure 2. shows examples of display (1/64 duty cycle) when the start line = 0-3. When the display duty cycle is 1/64 or more (ex. 1/32, 1/24 etc.), the data of total line number of LCD screen, from the line specified by display start line instruction, is displayed.

Set Page (X Address)

R/W	D/I	DB7	DB6	DB5	DB4	DB3	DB2	DB1	DB0
0	0	1	0	1	1	1	A	A	A

X address AAA (binary) of the display data RAM is set in the X address register. After that, writing or reading to or from MPU is executed in this specified page until the next page is set. See Figure 1.

Set Y Address

R/W	D/I	DB7	DB6	DB5	DB4	DB3	DB2	DB1	DB0
0	0	0	1	A	A	A	A	A	A

Y address AAAAAA (binary) of the display data RAM is set in the Y address counter. After that, Y address counter is increased by 1 every time the data is written or read to or from MPU.

Status Read

R/W	D/I	DB7	DB6	DB5	DB4	DB3	DB2	DB1	DB0
0	0	Busy	0	On/Off	RESET	0	0	0	0



•Busy

When busy is 1, the LSI is executing internal operations. No instruction are accepted while busy is 1, so you should make sure that busy is 0 before writing the next instruction.

•ON/OFF

Shows the liquid crystal display condition: on condition or off condition.

When on/off is 1, the display is in off condition.

When on/off is 0, the display is in on condition.

•RESET

RESET = 1 shows that the system system is being initialized. In this condition, no instructions except status read can be accepted.

RESET = 0 shows that initializing has system is in the usual operation condition.

Write Display Data

R/W	D/I	DB7	DB6	DB5	DB4	DB3	DB2	DB1	DB0
0	0	D	D	D	D	D	D	D	D

Writes 8-bit data DDDDDDDD (binary) into the display data RAM. The Y address is increased by 1 automatically.

Read Display Data

R/W	D/I	DB7	DB6	DB5	DB4	DB3	DB2	DB1	DB0
0	0	D	D	D	D	1	D	D	D

Reads out 8-bit data DDDDDDDD (binary) from the display data RAM. Then Y address is increased by 1 automatically.



One dummy read is necessary right after the address setting. For details, refer to the explanation of output register in “Function of Each Block”.

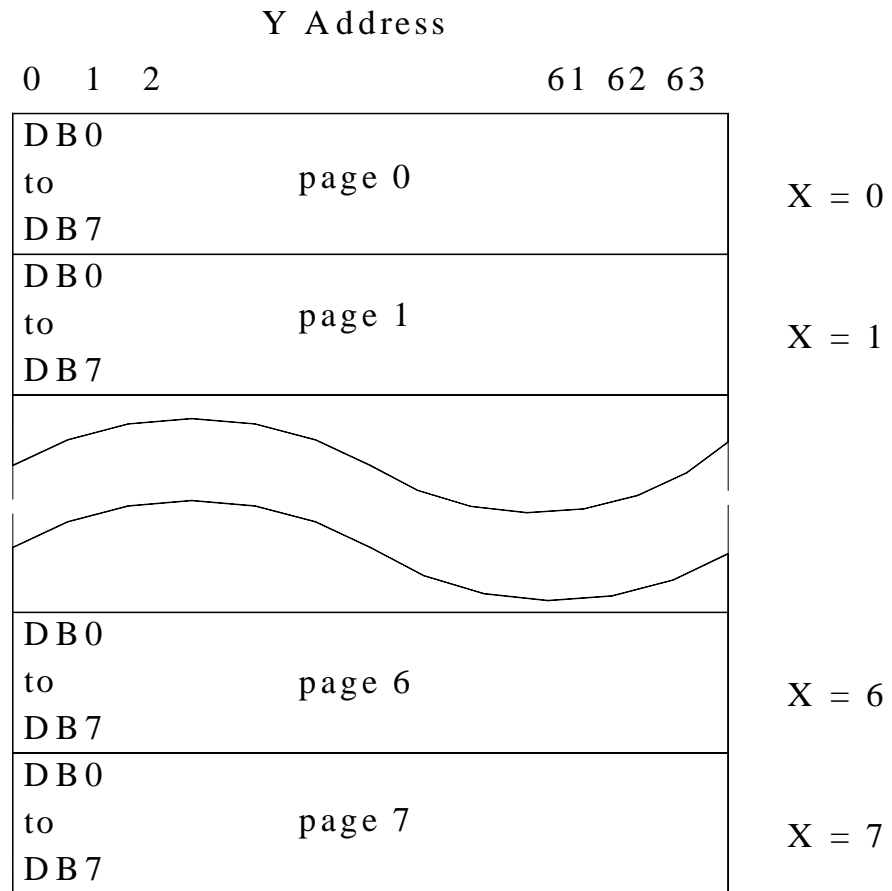
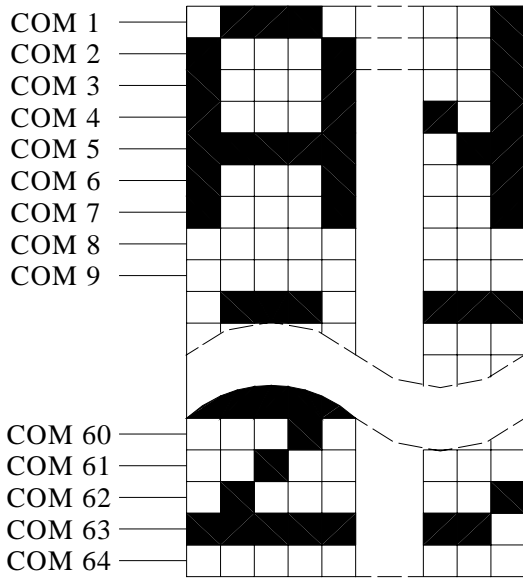
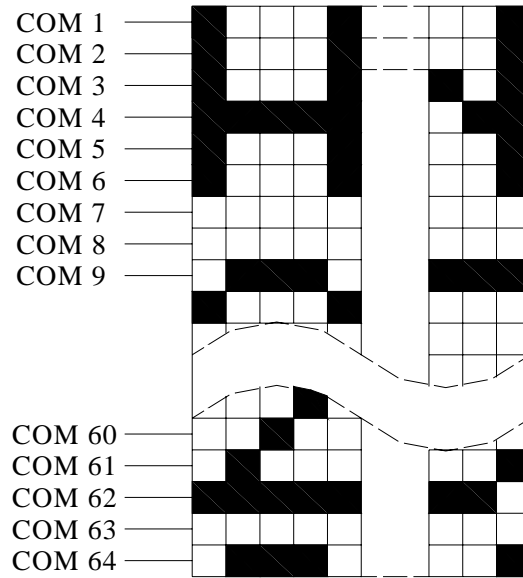

Figure 1.



Start line = 0



Start line = 1

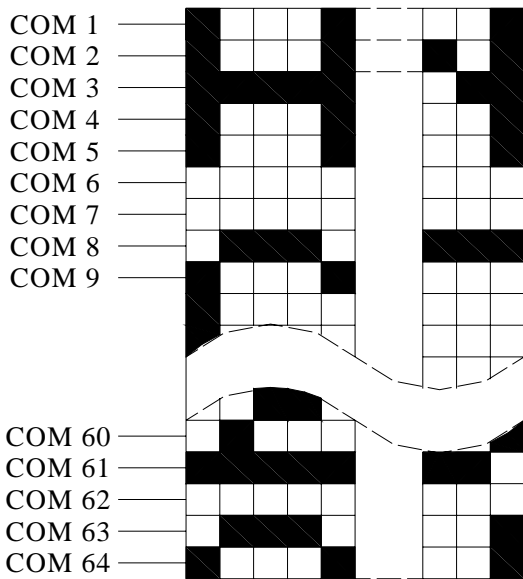

Start line = 3

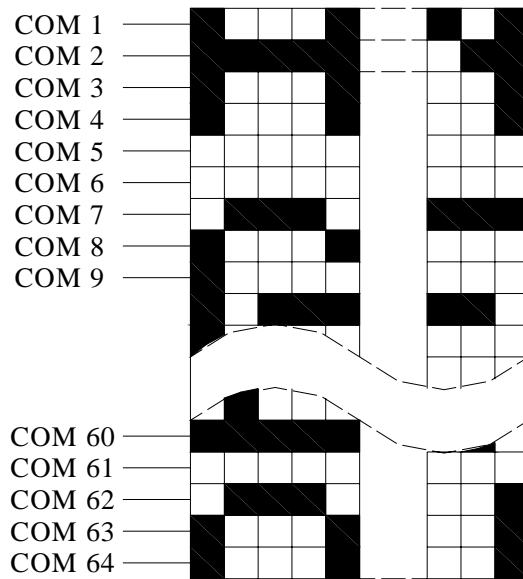

Start line = 4

Figure 2.



11. Quality Assurance

◆ Screen Cosmetic Criteria

No.	Defect	Judgement Criterion	Partition																				
1	Spots	<p>A) Clear</p> <table border="1"> <thead> <tr> <th>Size:d mm</th> <th>Acceptable Qty in active area</th> </tr> </thead> <tbody> <tr> <td>$d \leq 0.1$</td> <td>Disregard</td> </tr> <tr> <td>$0.1 < d \leq 0.2$</td> <td>6</td> </tr> <tr> <td>$0.2 < d \leq 0.3$</td> <td>2</td> </tr> <tr> <td>$0.3 < d$</td> <td>0</td> </tr> </tbody> </table> <p>Note: Including pin holes and defective dots which must be within one pixel size.</p> <p>B) Unclear</p> <table border="1"> <thead> <tr> <th>Size:d mm</th> <th>Acceptable Qty in active area</th> </tr> </thead> <tbody> <tr> <td>$d \leq 0.2$</td> <td>Disregard</td> </tr> <tr> <td>$0.2 < d \leq 0.5$</td> <td>6</td> </tr> <tr> <td>$0.5 < d \leq 0.7$</td> <td>2</td> </tr> <tr> <td>$0.7 < d$</td> <td>0</td> </tr> </tbody> </table>	Size:d mm	Acceptable Qty in active area	$d \leq 0.1$	Disregard	$0.1 < d \leq 0.2$	6	$0.2 < d \leq 0.3$	2	$0.3 < d$	0	Size:d mm	Acceptable Qty in active area	$d \leq 0.2$	Disregard	$0.2 < d \leq 0.5$	6	$0.5 < d \leq 0.7$	2	$0.7 < d$	0	Minor
Size:d mm	Acceptable Qty in active area																						
$d \leq 0.1$	Disregard																						
$0.1 < d \leq 0.2$	6																						
$0.2 < d \leq 0.3$	2																						
$0.3 < d$	0																						
Size:d mm	Acceptable Qty in active area																						
$d \leq 0.2$	Disregard																						
$0.2 < d \leq 0.5$	6																						
$0.5 < d \leq 0.7$	2																						
$0.7 < d$	0																						
2	Bubbles in Polarizer	<table border="1"> <thead> <tr> <th>Size:d mm</th> <th>Acceptable Qty in active area</th> </tr> </thead> <tbody> <tr> <td>$d \leq 0.3$</td> <td>Disregard</td> </tr> <tr> <td>$0.3 < d \leq 1.0$</td> <td>3</td> </tr> <tr> <td>$1.0 < d \leq 1.5$</td> <td>1</td> </tr> <tr> <td>$1.5 < d$</td> <td>0</td> </tr> </tbody> </table>	Size:d mm	Acceptable Qty in active area	$d \leq 0.3$	Disregard	$0.3 < d \leq 1.0$	3	$1.0 < d \leq 1.5$	1	$1.5 < d$	0	Minor										
Size:d mm	Acceptable Qty in active area																						
$d \leq 0.3$	Disregard																						
$0.3 < d \leq 1.0$	3																						
$1.0 < d \leq 1.5$	1																						
$1.5 < d$	0																						
3	Scratch	In accordance with spots cosmetic criteria. When the light reflects on the panel surface, the scratches are not to be remarkable.	Minor																				
4	Allowable Density	Above defects should be separated more than 30mm each other.	Minor																				
5	Coloration	Not to be noticeable coloration in the viewing area of the LCD panels. Back-light type should be judged with back-light on state only.	Minor																				



12. Reliability

Content of Reliability Test

Environmental Test				
No.	Test Item	Content of Test	Test Condition	Applicable Standard
1	High Temperature storage	Endurance test applying the high storage temperature for a long time.	80°C 200hrs	—
2	Low Temperature storage	Endurance test applying the high storage temperature for a long time.	-30°C 200hrs	—
3	High Temperature Operation	Endurance test applying the electric stress (Voltage & Current) and the thermal stress to the element for a long time.	70°C 200hrs	—
4	Low Temperature Operation	Endurance test applying the electric stress under low temperature for a long time.	-20°C 200hrs	—
5	High Temperature/ Humidity Storage	Endurance test applying the high temperature and high humidity storage for a long time.	60°C, 90%RH 96hrs	—
6	High Temperature/ Humidity Operation	Endurance test applying the electric stress (Voltage & Current) and temperature / humidity stress to the element for a long time.	40°C, 90%RH 96hrs	—
7	Temperature Cycle	Endurance test applying the low and high temperature cycle. $\begin{array}{ccc} -30^{\circ}\text{C} & 25^{\circ}\text{C} & 80^{\circ}\text{C} \\ \longleftarrow & & \longrightarrow \\ 30\text{min} & 5\text{min} & 30\text{min} \end{array}$ 1 cycle	-30°C/80°C 10 cycles	—
Mechanical Test				
8	Vibration test	Endurance test applying the vibration during transportation and using.	10~22Hz→1.5mmp-p 22~500Hz→1.5G Total 0.5hrs	—
9	Shock test	Constructional and mechanical endurance test applying the shock during transportation.	50G Half sign wave 11 msdc 3 times of each direction	—
10	Atmospheric pressure test	Endurance test applying the atmospheric pressure during transportation by air.	115mbar 40hrs	—
Others				
11	Static electricity test	Endurance test applying the electric stress to the terminal.	VS=800V,RS=1.5kΩ CS=100pF 1 time	—

***Supply voltage for logic system=5V. Supply vo



13.Outline Dimension

