

BGS13AL12

SP3T Antenna Switch with Antenna Termination Port

Data Sheet

Revision 1.1, 2009-06-25
Preliminary

Industrial & Multimarket

Edition 2009-06-25

**Published by
Infineon Technologies AG
81726 Munich, Germany**

**© 2009 Infineon Technologies AG
All Rights Reserved.**

Legal Disclaimer

The information given in this document shall in no event be regarded as a guarantee of conditions or characteristics. With respect to any examples or hints given herein, any typical values stated herein and/or any information regarding the application of the device, Infineon Technologies hereby disclaims any and all warranties and liabilities of any kind, including without limitation, warranties of non-infringement of intellectual property rights of any third party.

Information

For further information on technology, delivery terms and conditions and prices, please contact the nearest Infineon Technologies Office (www.infineon.com).

Warnings

Due to technical requirements, components may contain dangerous substances. For information on the types in question, please contact the nearest Infineon Technologies Office.

Infineon Technologies components may be used in life-support devices or systems only with the express written approval of Infineon Technologies, if a failure of such components can reasonably be expected to cause the failure of that life-support device or system or to affect the safety or effectiveness of that device or system. Life support devices or systems are intended to be implanted in the human body or to support and/or maintain and sustain and/or protect human life. If they fail, it is reasonable to assume that the health of the user or other persons may be endangered.

BGS13AL12, SP3T Antenna Switch with Antenna Termination Port

Revision History: 2009-06-25, Revision 1.1

Previous Revision: 2009-05-04, Revision 1.0

Page	Subjects (major changes since last revision)
	Converted to the new IFX FrameMaker Template.
9	Pin13 Pin Description
11,12	Electrical Specifications
13	Application Board, Deembedding Board
14	Pin Marking

Trademarks of Infineon Technologies AG

APOXI™, BlueMoon™, COMNEON™, CONVERGATE™, COSIC™, C166™, CROSSAVE™, CanPAK™, CIPOS™, CoolMOS™, CoolSET™, CORECONTROL™, DAVE™, EasyPIM™, EconoBRIDGE™, EconoDUAL™, EconoPACK™, EconoPIM™, EiceDRIVER™, EUPEC™, FCOS™, FALC™, GEMINAX™, GOLDMOS™, HITFET™, HybridPACK™, ISAC™, ISOFACE™, IsoPACK™, my-d™, MIPAQ™, ModSTACK™, NovalithIC™, OmniTune™, OmniVia™, OPTIVERSE™, OptiMOS™, ORIGA™, PROFET™, PRO-SIL™, PrimePACK™, RASIC™, ReverSave™, SCEPTRE™, SEROCCO™, SICOFI™, SMARTi™, SMINT™, SOCRATES™, SatRIC™, SensoNor™, SINDRION™, SmartLEWIS™, SIEGET™, TrueENTRY™, TEMPFET™, TriCore™, thinQ!™, TRENCHSTOP™, VINAX™, VINETIC™, X-GOLD™, XMM™, X-PMU™, XPOSYS™, XWAY™.

Other Trademarks

AMBA™, ARM™, MULTI-ICE™, PRIMECELL™, REALVIEW™, THUMB™ of ARM Limited, UK. AUTOSAR™ is licensed by AUTOSAR development partnership. Bluetooth™ of Bluetooth SIG Inc. CAT-iq™ of DECT Forum. COLOSSUS™, FirstGPS™ of Trimble Navigation Ltd. EMV™ of EMVCo, LLC (Visa Holdings Inc.). EPCOS™ of Epcos AG. FLEXGO™ of Microsoft Corporation. FlexRay™ is licensed by FlexRay Consortium. HYPERTERMINAL™ of Hilgraeve Incorporated. IEC™ of Commission Electrotechnique Internationale. IrDA™ of Infrared Data Association Corporation. ISO™ of INTERNATIONAL ORGANIZATION FOR STANDARDIZATION. MATLAB™ of MathWorks, Inc. MAXIM™ of Maxim Integrated Products, Inc. MICROTEC™, NUCLEUS™ of Mentor Graphics Corporation. Mifare™ of NXP. MIPI™ of MIPI Alliance, Inc. MIPS™ of MIPS Technologies, Inc., USA. muRata™ of MURATA MANUFACTURING CO. OmniVision™ of OmniVision Technologies, Inc. Openwave™ Openwave Systems Inc. RED HAT™ Red Hat, Inc. RFMD™ RF Micro Devices, Inc. SIRIUS™ of Sirius Sattelite Radio Inc. SOLARIS™ of Sun Microsystems, Inc. SPANSION™ of Spansion LLC Ltd. Symbian™ of Symbian Software Limited. TAIYO YUDEN™ of Taiyo Yuden Co. TEAKLITE™ of CEVA, Inc. TEKTRONIX™ of Tektronix Inc. TOKO™ of TOKO KABUSHIKI KAISHA TA. UNIX™ of X/Open Company Limited. VERILOG™, PALLADIUM™ of Cadence Design Systems, Inc. VLYNQ™ of Texas Instruments Incorporated. VXWORKS™, WIND RIVER™ of WIND RIVER SYSTEMS, INC. ZETEX™ of Diodes Zetex Limited.

Last Trademarks Update 2009-05-27

Table of Contents

	Table of Contents	4
	List of Figures	5
	List of Tables	6
1	Features	7
2	Signals Description	9
3	Electrical Characteristics	10
3.1	Electrical Specification	11
4	Application Board	13
4.1	Deembedding Board	13
5	Package Outlines	14

List of Figures

Figure 1	Functional Diagram.	8
Figure 2	Pin Configuration (top view)	9
Figure 3	Application Board with External Parallel Inductor L1 (15 nH) at Ant Port.	13
Figure 4	Deembedding Board.	13
Figure 5	Package Outlines	14
Figure 6	Pin Marking.	14
Figure 7	Land Pattern and Stencil Mask.	15

List of Tables

Table 1	Pin Description (top view)	9
Table 2	Truth Table	9
Table 3	Absolute Maximum Ratings	10
Table 4	Operating Ranges	10
Table 5	ESD Ratings	10
Table 6	Electrical Characteristics	11
Table 7	Electrical Characteristics (cont'd)	12

1 Features

Main Features:

- 3 high-linearity Rx ports with power handling capability of up to 30 dBm
- Antenna Termination Port
- No external decoupling components required
- Small leadless package TSLP12
- High ESD robustness
- Low harmonic generation
- Low insertion loss
- High port-to-port-isolation
- 0.1 to 3.0 GHz coverage
- On-chip control logic supporting logic levels from 1.4 V to 3.0 V
- Lead and halogen free package (RoHS and WEEE compliant)

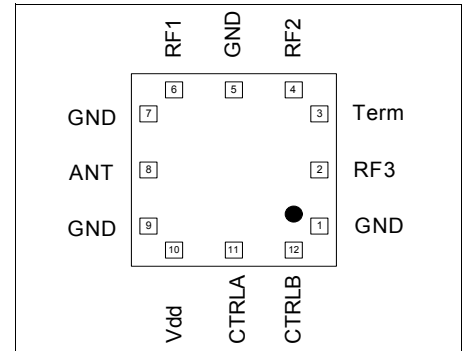

Applications

- WCDMA diversity
- CDMA diversity
- Analog and Digital Tuner
- Band Switching

Product Name	Product Type	Package
SP3T RF Switch	BGS13AL12	PG-TSLP-12-3

Description

The BGS13AL12 RF MOS switch is specifically designed for WCDMA diversity applications. An additional 4th port allows proper termination of the antenna when turned off.

This SP3T offers low insertion loss and high robustness against interferer signals at the antenna port, while maintaining a very small size of only 2.0 x 2.0 mm² and a maximum height of only 0.4 mm

The on-chip controller integrates CMOS logic and level shifters, driven by control inputs from 1.4 to 3.0 V. Unlike GaAs technology, external DC blocking capacitors at the RF Ports are only required if DC voltage is applied externally.

The BGS13AL12 RF Switch is manufactured in Infineon's patented MOS technology, offering the performance of GaAs with the economy and integration of conventional CMOS including the inherent higher ESD robustness.

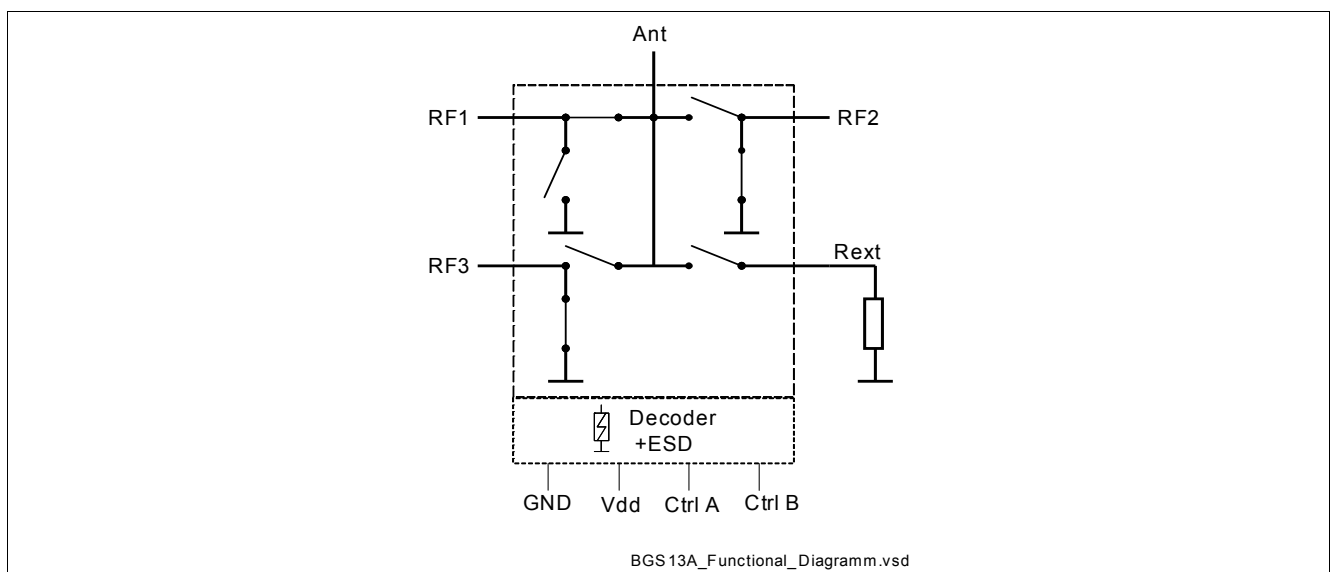

Figure 1 Functional Diagram

2 Signals Description

Table 1 Pin Description (top view)

Pin No.	Name	Pin Type	Buffer Type	Function
1	GND	GND		Ground
2	RF3	I/O		Rx RF port 3
3	Term	I/O		Ext. Term Port
4	RF2	I/O		Rx RF port 2
5	GND	GND		Ground
6	RF1	I/O		Rx RF port 1
7	GND	GND		Ground
8	Ant	I/O		Antenna port
9	GND	GND		Ground
10	Vdd	PWR		Vdd supply
11	CTRL A	I		Control pin A
12	CTRL B	I		Control pin B
13	NC	NC		For thermal reasons recommended to connect to Ground

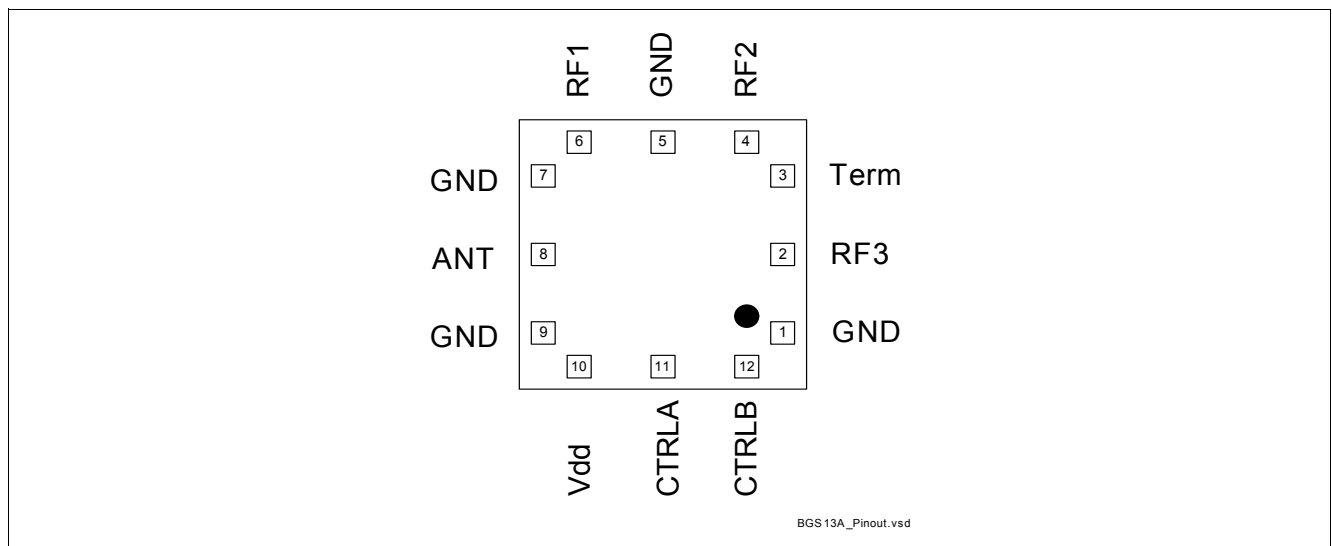

Figure 2 Pin Configuration (top view)

Table 2 Truth Table

Function	Ctrl A	Ctrl B
Ant → RF1	H	H
Ant → RF2	L	H
Ant → RF3	H	L
Ant → Term	L	L

3 Electrical Characteristics

Table 3 Absolute Maximum Ratings

Parameter	Symbol	Values			Unit	Note / Test Condition
		Min.	Typ.	Max.		
Storage Temperature Range	T_{stg}	-65	–	150	°C	–
DC Voltage at all pins to GND	V_{DC}	–	–	3.2	V	–
Max RF power at antenna port, any RF port on	$P_{Ant IN max}$	–	–	32	dBm	–

Table 4 Operating Ranges

Parameter	Symbol	Values			Unit	Note / Test Condition
		Min.	Typ.	Max.		
Ambient Temperature	T_A	-30	–	85	°C	–
RF Frequency	f	0.1	–	3	GHz	–
Control Voltage low	V_{CtrlL}	-0.3	–	0.3	V	–
Control Voltage high	V_{CtrlH}	1.4	–	V_{dd}	V	–
Supply Voltage	V_{dd}	2.70	–	3.0	V	–
Max. Input (Reverse) Power at antenna pin	Pin	–	–	30	dBm	–

Table 5 ESD Ratings

Parameter	Symbol	Values			Unit	Note / Test Condition
		Min.	Typ.	Max.		
Human Body-Model IEC 61340-3-1, all pins	V_{max}	–	–	500	V	–
Human Body-Model IEC 61340-3-1, antenna port	V_{max}	–	–	1000	V	–

ESD robustness of antenna port can be increased to 8 kV IEC-61000-4-2 with external protection circuit.

Attention: Stresses above the max. values listed here may cause permanent damage to the device. Exposure to absolute maximum rating conditions for extended periods may affect device reliability. Maximum ratings are absolute ratings; exceeding only one of these values may cause irreversible damage to the integrated circuit.

3.1 Electrical Specification

Test Conditions:

- Termination port impedance: $Z_0 = 50 \Omega$
- Temperature range: $T_A = -30 \text{ }^\circ\text{C} \dots +85 \text{ }^\circ\text{C}$
- Supply Voltage: $V_{dd} = 2.8 \text{ V}$
- $P_{in} = 15 \text{ dBm}$
- Across operating range of control voltages: $V_{Ctrl} = 1.4 \dots 2.8 \text{ V}$

Table 6 Electrical Characteristics

Parameter	Symbol	Values			Unit	Note / Test Condition
		Min.	Typ.	Max.		
Insertion Loss						
824<f<960 MHz		–	0.45/0.75 ¹⁾	0.65/1.0 ¹⁾	dB	–
1710<f<1980 MHz		–	0.8/0.7 ¹⁾	1.0/0.9 ¹⁾	dB	–
1980<f<2170 MHz		–	0.9/0.8 ¹⁾	1.1/1.0 ¹⁾	dB	–
Inband ripple Rx ports (high bands)		–	–	0.2	dB	–
Inband ripple Rx ports (low bands)		–	–	0.2	dB	–
Return Loss¹⁾						
All ports @ 0.9 GHz		14	–	–	dB	–
All ports @ 2 GHz		12	–	–	dB	–
Isolation Ant – RF1,2,3						
0.9 GHz		20	–	–	dB	–
2 GHz		20	–	–	dB	–
Isolation RF1,2,3 – RF1,2,3						
0.9 GHz		20	–	–		–
2 GHz		20	–	–		–
Isolation RF Ports – V_{dd}, V_{ctrl}						
0.9 GHz		20	–	–	dB	–
2 GHz		20	–	–	dB	–

1) With external parallel Inductor (15 nH) at Ant port

Table 7 Electrical Characteristics (cont'd)

Parameter	Symbol	Values			Unit	Note / Test Condition
		Min.	Typ.	Max.		
Input Intercept Point Requirements - IMD2¹⁾						
Tx=10 dBm@ ant port, Int=-15 dBm @ant port (TX Freq = 824 - 915 MHz)		–	-115	-100	dBm	–
Tx=10 dBm@ ant port, Int=-15 dBm @ant port (TX Freq=1710 - 1980 MHz)		–	-110	-100	dBm	–
Input Intercept Point Requirements – IMD3¹⁾						
Tx=10 dBm@ ant port, Int= -15 dBm @ant port(TX Freq = 824 - 915 MHz)		–	-110	-107	dBm	–
Tx=10 dBm@ ant port, Int=-15 dBm @ant port (TX Freq=1710 - 1980 MHz)		–	-110	-107	dBm	–
Triple Beat Ratio						
Tx1=21.5 dBm, Tx2=21.5 dBm, Int=-30 dBm (650 MHz - 900 MHz)		–	-83	–	dBc	–
Tx1=21.5 dBm, Tx2=21.5 dBm, Int=-30 dBm (1710 MHz - 2155 MHz)		–	-82	–	dBc	–
Harmonic Generation RF ports up to 12.75 GHz						
Pin (UMTS) = 23 dBm, Duty Cycle = 100%, unused RF pins = any load, VSWR = 4:1		–	–	–	–	–
1 GHz		–	–	-46	dBm	–
2 GHz		–	–	-46	dBm	–
Harmonic Generation Termination port up to 12.75 GHz						
Pin (UMTS) = 30 dBm at low band, 22 dBm at high band, Duty Cycle = 25%		–	–	–	–	–
1 GHz, Second Harmonic		–	–	-40	dBm	–
1 GHz, all other Harmonics up to 12.75GHz		–	–	-46	dBm	–
2 GHz		–	–	-44	dBm	–
Switching Time and Current Consumption						
On/Off Switching Time (10-90%) RF		–	–	5	μs	–
Current Consumption at Vdd Pin		–	200	500	μA	–
Current Consumption at Vctrl Pins		–	<1	30	μA	–

1) With external parallel inductor (15 nH) at Ant port

4 Application Board

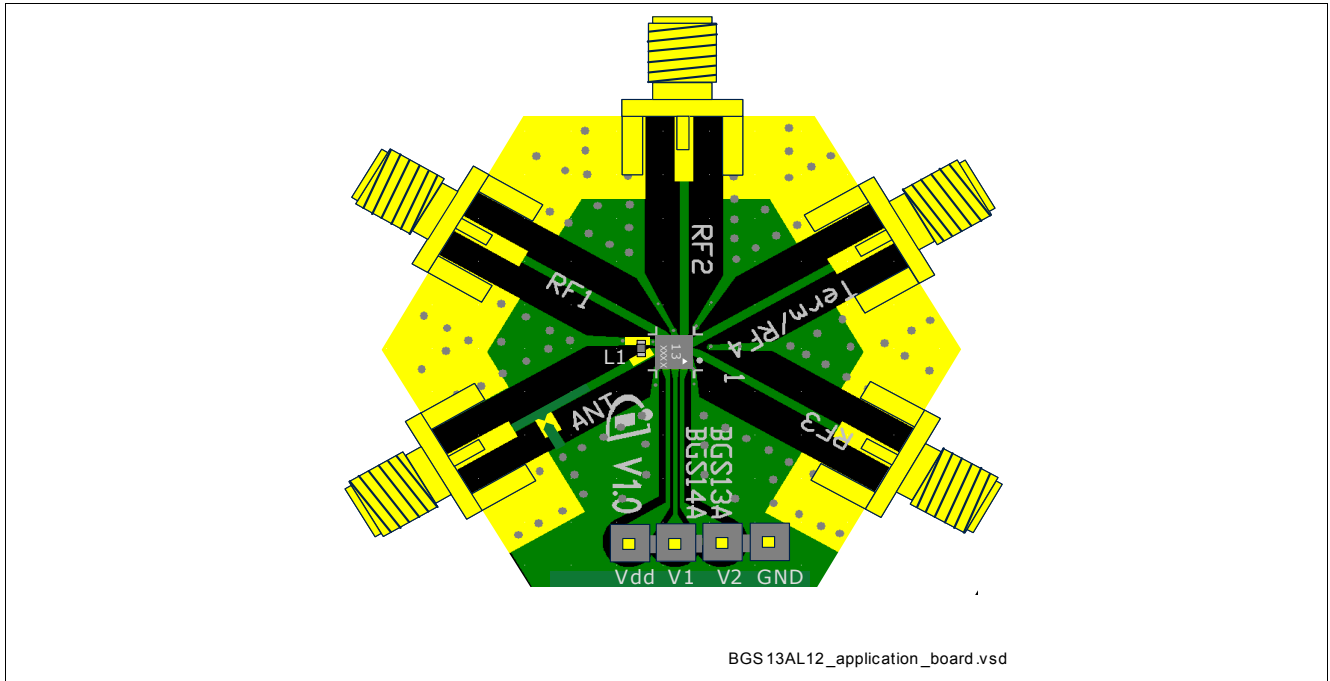

Figure 3 Application Board with External Parallel Inductor L1 (15 nH) at Ant Port

4.1 Deembedding Board

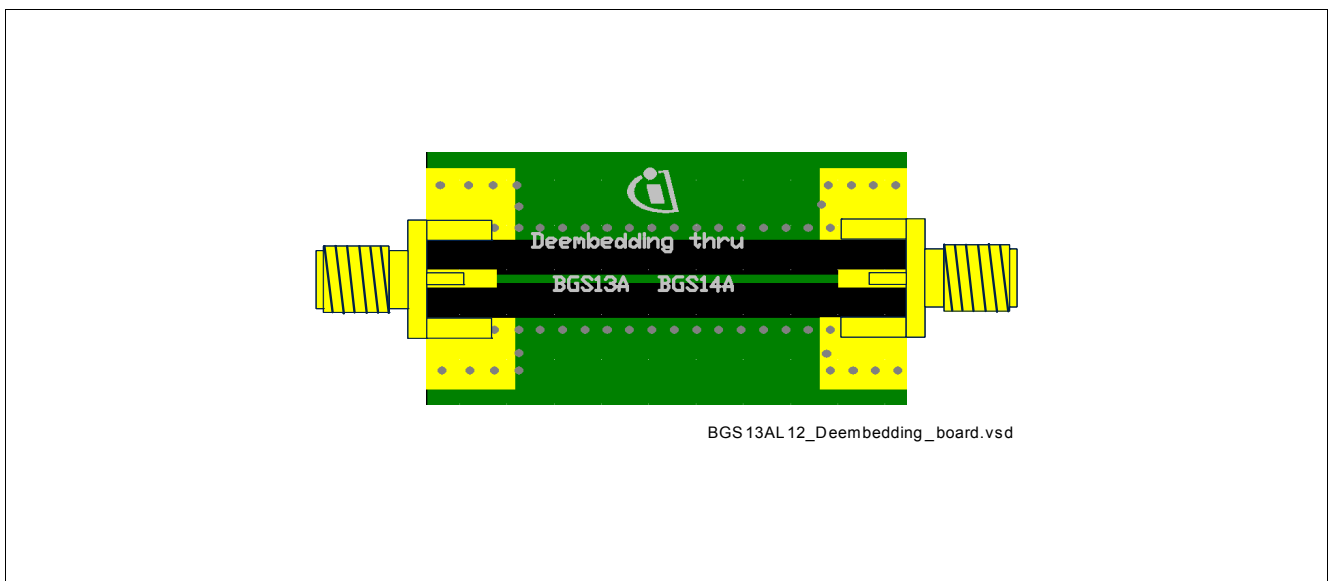

Figure 4 Deembedding Board

5 Package Outlines

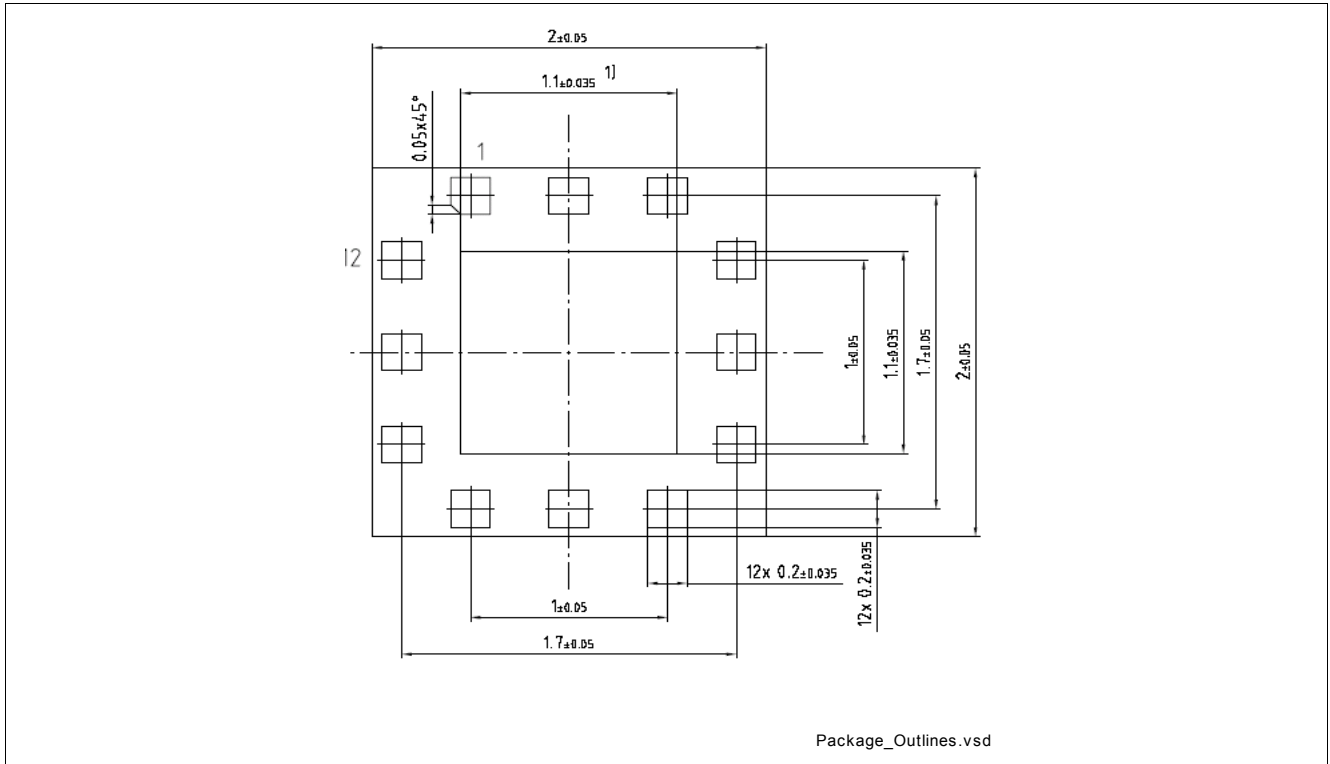

Figure 5 Package Outlines

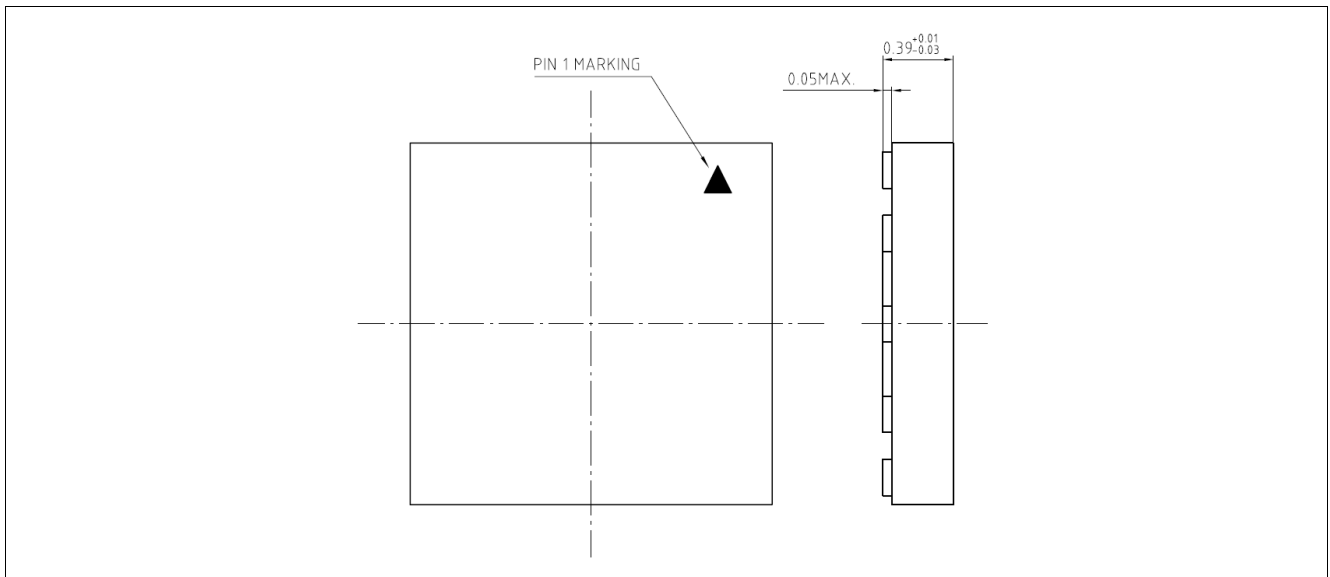

Figure 6 Pin Marking

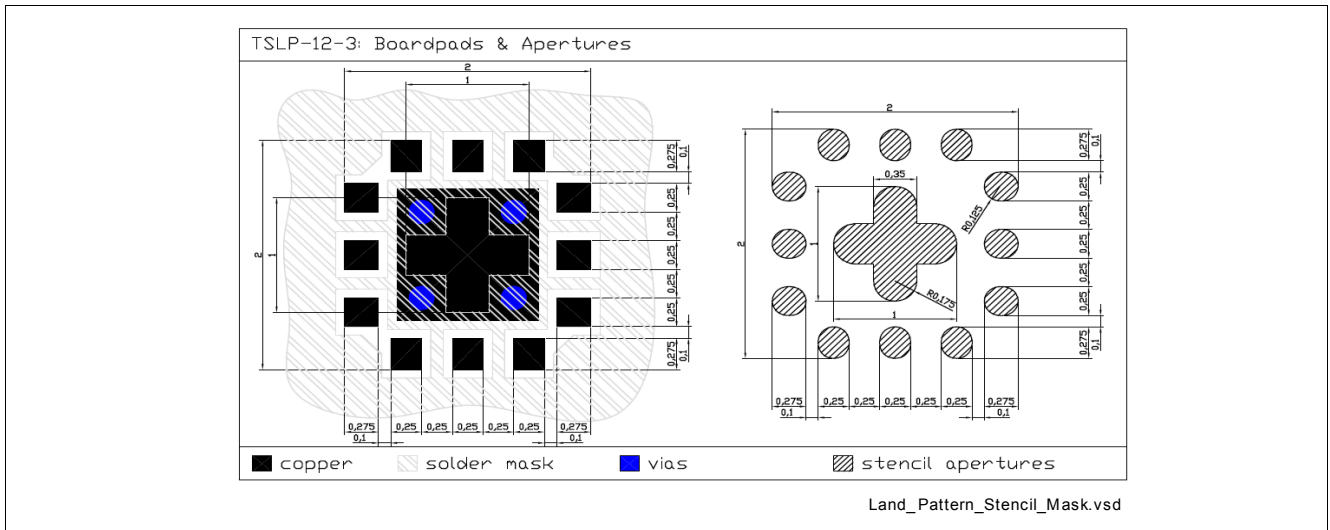

Figure 7 Land Pattern and Stencil Mask

www.infineon.com

Published by Infineon Technologies AG