

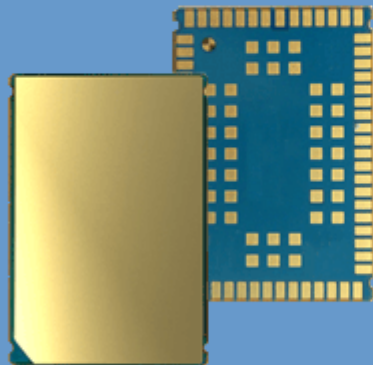

**CINTERION**  
a Gemalto company

## BGS2-E/BGS2-W

Version: 01.301  
DocId: BGS2\_HID\_v01.301



# Hardware Interface Description

Document Name: **BGS2-E/BGS2-W Hardware Interface Description**

Version: **01.301**

Date: **2011-04-07**

DocId: **BGS2\_HID\_v01.301**

Status: **Confidential / Released**

**GENERAL NOTE**

THE USE OF THE PRODUCT INCLUDING THE SOFTWARE AND DOCUMENTATION (THE "PRODUCT") IS SUBJECT TO THE RELEASE NOTE PROVIDED TOGETHER WITH PRODUCT. IN ANY EVENT THE PROVISIONS OF THE RELEASE NOTE SHALL PREVAIL. THIS DOCUMENT CONTAINS INFORMATION ON CINTERION PRODUCTS. THE SPECIFICATIONS IN THIS DOCUMENT ARE SUBJECT TO CHANGE AT CINTERION'S DISCRETION. CINTERION WIRELESS MODULES GMBH GRANTS A NON-EXCLUSIVE RIGHT TO USE THE PRODUCT. THE RECIPIENT SHALL NOT TRANSFER, COPY, MODIFY, TRANSLATE, REVERSE ENGINEER, CREATE DERIVATIVE WORKS; DISASSEMBLE OR DECOMPILE THE PRODUCT OR OTHERWISE USE THE PRODUCT EXCEPT AS SPECIFICALLY AUTHORIZED. THE PRODUCT AND THIS DOCUMENT ARE PROVIDED ON AN "AS IS" BASIS ONLY AND MAY CONTAIN DEFICIENCIES OR INADEQUACIES. TO THE MAXIMUM EXTENT PERMITTED BY APPLICABLE LAW, CINTERION WIRELESS MODULES GMBH DISCLAIMS ALL WARRANTIES AND LIABILITIES. THE RECIPIENT UNDERTAKES FOR AN UNLIMITED PERIOD OF TIME TO OBSERVE SECRECY REGARDING ANY INFORMATION AND DATA PROVIDED TO HIM IN THE CONTEXT OF THE DELIVERY OF THE PRODUCT. THIS GENERAL NOTE SHALL BE GOVERNED AND CONSTRUED ACCORDING TO GERMAN LAW.

**Copyright**

Transmittal, reproduction, dissemination and/or editing of this document as well as utilization of its contents and communication thereof to others without express authorization are prohibited. Offenders will be held liable for payment of damages. All rights created by patent grant or registration of a utility model or design patent are reserved.

Copyright © 2011, Cinterion Wireless Modules GmbH

**Trademark Notice**

Microsoft and Windows are either registered trademarks or trademarks of Microsoft Corporation in the United States and/or other countries. All other registered trademarks or trademarks mentioned in this document are property of their respective owners.

## Contents

<b>0</b>	<b>Document History .....</b>	<b>9</b>
<b>1</b>	<b>Introduction .....</b>	<b>10</b>
1.1	Related Documents .....	10
1.2	Terms and Abbreviations .....	10
1.3	Regulatory and Type Approval Information .....	14
1.3.1	Directives and Standards .....	14
1.3.2	SAR requirements specific to portable mobiles .....	17
1.3.3	Safety Precautions .....	18
<b>2</b>	<b>Product Concept .....</b>	<b>19</b>
2.1	Key Features at a Glance .....	19
2.2	BGS2-E/BGS2-W System Overview .....	21
2.3	Circuit Concept .....	22
<b>3</b>	<b>Application Interface.....</b>	<b>23</b>
3.1	Operating Modes .....	24
3.2	Power Supply .....	25
3.2.1	Minimizing Power Losses .....	25
3.2.2	Measuring the Supply Voltage (VBATT+) .....	26
3.2.3	Monitoring Power Supply by AT Command .....	26
3.3	Power Up/Power Down Scenarios .....	27
3.3.1	Turn on BGS2-E/BGS2-W .....	27
3.3.1.1	Switch on BGS2-E/BGS2-W Using ON Signal .....	27
3.3.1.2	Suppressing Unintentional Pulses on ON Signal Line .....	29
3.3.1.3	Turn on BGS2-E/BGS2-W Using the RTC (Alarm Mode) ...	30
3.3.2	Restart BGS2-E/BGS2-W .....	30
3.3.2.1	Restart BGS2-E/BGS2-W via AT+CFUN Command .....	30
3.3.2.2	Restart BGS2-E/BGS2-W Using EMERG_RST .....	31
3.3.3	Signal States after Startup .....	32
3.3.4	Turn off BGS2-E/BGS2-W .....	34
3.3.4.1	Switch off BGS2-E/BGS2-W Using AT Command .....	34
3.3.5	Automatic Shutdown .....	36
3.3.5.1	Thermal Shutdown .....	36
3.3.5.2	Undervoltage Shutdown .....	37
3.3.5.3	Overvoltage Shutdown .....	37
3.4	Automatic GPRS Multislot Class Change .....	38
3.5	Power Saving .....	39
3.5.1	No Power Saving (AT+CFUN=1) .....	39
3.5.2	NON-CYCLIC SLEEP Mode (AT+CFUN=0) .....	39
3.5.3	CYCLIC SLEEP Mode AT+CFUN=7 .....	40
3.5.4	CYCLIC SLEEP Mode AT+CFUN=9 .....	40
3.5.5	Timing of the CTS Signal in CYCLIC SLEEP Modes .....	40

3.5.6	Wake up BGS2-E/BGS2-W from SLEEP Mode.....	42
3.5.6.1	Wake-up via RTS0 and RTS1 (if AT+CFUN=0 or AT+CFUN=9).....	43
3.6	Summary of State Transitions (except SLEEP Mode).....	43
3.7	RTC Backup.....	44
3.8	SIM/USIM Interface.....	45
3.9	Serial Interface ASC0 .....	47
3.10	Serial Interface ASC1 .....	50
3.11	Analog Audio Interface.....	52
3.11.1	Microphone Inputs and Supply .....	52
3.11.2	Loudspeaker Output .....	54
3.12	GPIO Interface .....	55
3.13	I <sup>2</sup> C Interface .....	57
3.14	PWM Interfaces .....	59
3.15	Status LED.....	59
3.16	Behavior of the RING0 Line (ASC0 Interface only).....	60
3.17	Power Indication Circuit .....	61
<b>4</b>	<b>Antenna Interface.....</b>	<b>63</b>
4.1	Antenna Installation .....	64
4.2	RF Line Routing Design.....	65
4.2.1	Line Arrangement Examples.....	65
4.2.1.1	Embedded Stripline .....	65
4.2.1.2	Micro-Stripline .....	66
4.2.2	Routing Example.....	70
4.2.2.1	Interface to RF Connector.....	70
<b>5</b>	<b>Electrical, Reliability and Radio Characteristics.....</b>	<b>71</b>
5.1	Absolute Maximum Ratings .....	71
5.2	Operating Temperatures.....	72
5.3	Reliability Characteristics.....	73
5.4	Pad Assignment and Signal Description.....	74
5.5	Power Supply Ratings.....	82
5.6	Electrical Characteristics of the Voiceband Part.....	83
5.6.1	Setting Audio Parameters by AT Commands .....	83
5.6.2	Audio Programming Model .....	84
5.6.3	Characteristics of Audio Modes .....	85
5.6.4	Voiceband Receive Path.....	86
5.6.5	Voiceband Transmit Path.....	87
5.7	Antenna Interface Specification .....	88
5.8	Electrostatic Discharge .....	89
<b>6</b>	<b>Mechanics, Mounting and Packaging .....</b>	<b>90</b>
6.1	Mechanical Dimensions of BGS2-E/BGS2-W.....	90
6.2	Mounting BGS2-E/BGS2-W onto the Application Platform.....	92
6.2.1	SMT PCB Assembly .....	92
6.2.1.1	Land Pattern and Stencil .....	92
6.2.1.2	Board Level Characterization.....	94

---

6.2.2	Moisture Sensitivity Level .....	94
6.2.3	Soldering Conditions and Temperature .....	95
6.2.3.1	Reflow Profile .....	95
6.2.3.2	Maximum Temperature and Duration .....	96
6.2.4	Durability and Mechanical Handling.....	97
6.2.4.1	Storage Conditions .....	97
6.2.4.2	Processing Life.....	98
6.2.4.3	Baking .....	98
6.2.4.4	Electrostatic Discharge.....	98
6.3	Packaging .....	99
6.3.1	Tape and Reel .....	99
6.3.1.1	Orientation.....	99
6.3.1.2	Barcode Label .....	100
6.3.2	Shipping Materials .....	101
6.3.2.1	Moisture Barrier Bag .....	101
6.3.2.2	Transportation Box .....	103
6.3.3	Trays .....	104
<b>7</b>	<b>Sample Application.....</b>	<b>105</b>
7.1	Blocking against RF on Interface Lines .....	107
<b>8</b>	<b>Reference Approval .....</b>	<b>109</b>
8.1	Reference Equipment for Type Approval.....	109
8.2	Compliance with FCC and IC Rules and Regulations .....	110
<b>9</b>	<b>Appendix.....</b>	<b>111</b>
9.1	List of Parts and Accessories.....	111

## Tables

Table 1:	Directives .....	14
Table 2:	Standards of North American type approval .....	14
Table 3:	Standards of European type approval.....	14
Table 4:	Requirements of quality .....	15
Table 5:	Standards of the Ministry of Information Industry of the People’s Republic of China .....	15
Table 6:	Toxic or hazardous substances or elements with defined concentration limits	16
Table 7:	Overview of operating modes .....	24
Table 8:	Signal states.....	32
Table 9:	Temperature dependent behavior .....	36
Table 10:	Wake-up events in NON-CYCLIC and CYCLIC SLEEP modes .....	42
Table 11:	State transitions of BGS2-E/BGS2-W (except SLEEP mode) .....	43
Table 12:	Signals of the SIM interface (SMT application interface) .....	45
Table 13:	DCE-DTE wiring of ASC0 .....	48
Table 14:	DCE-DTE wiring of ASC1 .....	50
Table 15:	GPIO assignment.....	55
Table 16:	Power indication circuit .....	61
Table 17:	Return loss in the active band.....	63
Table 18:	Absolute maximum ratings.....	71
Table 19:	Board temperature .....	72
Table 20:	Ambient temperature according to IEC 60068-2 (w/o forced air circulation)..	72
Table 21:	Ambient temperature with forced air circulation (air speed 0.9m/s).....	72
Table 22:	Summary of reliability test conditions .....	73
Table 23:	Pad assignments.....	75
Table 24:	Electrical description of application interface .....	76
Table 25:	Power supply ratings.....	82
Table 26:	Audio parameters adjustable by AT command .....	83
Table 27:	Voiceband characteristics (typical).....	85
Table 28:	Voiceband receive path.....	86
Table 29:	Voiceband transmit path .....	87
Table 30:	Antenna interface specifications .....	88
Table 31:	Measured electrostatic values.....	89
Table 32:	Reflow temperature ratings .....	95
Table 33:	Storage conditions .....	97
Table 34:	EMI measures on the application interface .....	108
Table 35:	List of parts and accessories.....	111
Table 36:	Molex sales contacts (subject to change) .....	112

## Figures

Figure 1:	BGS2-E/BGS2-W system overview .....	21
Figure 2:	BGS2-E/BGS2-W block diagram .....	22
Figure 3:	Power supply limits during transmit burst.....	25
Figure 4:	Position of reference points BATT+and GND .....	26
Figure 5:	ON circuit sample.....	27
Figure 6:	ON timing .....	28
Figure 7:	Sample circuit to suppress spikes or glitches on ON signal line .....	29
Figure 8:	Emergency restart timing .....	31
Figure 9:	Switch off behavior.....	35
Figure 10:	Timing of CTS signal (example for a 2.12 s paging cycle).....	41
Figure 11:	Beginning of power saving if CFUN=7 .....	41
Figure 12:	RTC supply variants.....	44
Figure 13:	External SIM card holder circuit .....	45
Figure 14:	VDIG controlled power supply domain.....	47
Figure 15:	Serial interface ASC0.....	48
Figure 16:	ASC0 startup behavior .....	49
Figure 17:	Serial interface ASC1.....	50
Figure 18:	ASC1 startup behavior .....	51
Figure 19:	Single ended microphone connection .....	53
Figure 20:	Differential Microphone connection.....	53
Figure 21:	Line Input .....	53
Figure 22:	Differential loudspeaker connection .....	54
Figure 23:	Line output connection .....	54
Figure 24:	GPIO startup behavior .....	56
Figure 25:	I <sup>2</sup> C interface connected to VCC of application .....	57
Figure 26:	I <sup>2</sup> C interface connected to V180 or V285.....	57
Figure 27:	I <sup>2</sup> C startup behavior .....	58
Figure 28:	Status signalling with LED driver.....	59
Figure 29:	Incoming voice call.....	60
Figure 30:	Incoming voice call.....	60
Figure 31:	URC transmission .....	60
Figure 32:	Power indication circuit .....	62
Figure 33:	Antenna pads (bottom view) .....	64
Figure 34:	Embedded Stripline with 65µm prepreg (1080) and 710µm core .....	65
Figure 35:	Micro-Stripline on 1.0mm standard FR4 2-layer PCB - example 1 .....	66
Figure 36:	Micro-Stripline on 1.0mm Standard FR4 PCB - example 2.....	67
Figure 37:	Micro-Stripline on 1.5mm Standard FR4 PCB - example 1.....	68
Figure 38:	Micro-Stripline on 1.5mm Standard FR4 PCB - example 2.....	69
Figure 39:	Putting to application's RF connector - top view .....	70
Figure 40:	Numbering plan for connecting pads (bottom view).....	74
Figure 41:	Audio programming model.....	84
Figure 42:	BGS2-E/BGS2-W– top and bottom view.....	90
Figure 43:	Dimensions of BGS2-E/BGS2-W (all dimensions in mm).....	91
Figure 44:	Land pattern (top view) .....	92
Figure 45:	Recommended design for 110 micron thick stencil (top view).....	93
Figure 46:	Recommended design for 150 micron thick stencil (top view).....	93
Figure 47:	Reflow Profile .....	95
Figure 48:	Carrier tape .....	99
Figure 49:	Reel direction .....	99
Figure 50:	Barcode label on tape reel .....	100

---

Figure 51:	Moisture barrier bag (MBB) with imprint.....	101
Figure 52:	Moisture Sensitivity Label .....	102
Figure 53:	Humidity Indicator Card - HIC .....	103
Figure 54:	Small quantity tray.....	104
Figure 55:	Tray to ship odd module amounts.....	104
Figure 56:	Trays with packaging materials.....	104
Figure 57:	Schematic diagram of BGS2-E/BGS2-W sample application .....	106
Figure 58:	EMI circuits.....	107
Figure 59:	Reference equipment for Type Approval .....	109



## 0 Document History

Preceding document: "BGS2-E/BGS2-W Hardware Interface Description" Version 00.100b

New document: "BGS2-E/BGS2-W Hardware Interface Description" Version **01.301**

Chapter	What is new
<a href="#">5.4</a>	Marked pad 64 as AGND pad in <a href="#">Figure 40</a> .
<a href="#">5.4</a> , <a href="#">6.1</a>	Updated layout for module's center pads.
<a href="#">6.2.1.1</a>	Updated section <a href="#">Land Pattern and Stencil</a> .
<a href="#">6.3.3</a>	New section on <a href="#">Trays</a> .
<a href="#">7</a>	Revised <a href="#">Figure 57</a> to show only two BATT+ pads.

Preceding document: "BGS2-E/BGS2-W Hardware Interface Description" Version 00.100a

New document: "BGS2-E/BGS2-W Hardware Interface Description" Version 00.100b

Chapter	What is new
<a href="#">2.1</a>	Added module weight.
<a href="#">3.2.2</a>	Added <a href="#">Figure 4</a> .
<a href="#">6.2.1.1</a>	Updated section <a href="#">Land Pattern and Stencil</a> .
<a href="#">6.2.3.1</a>	Updated section <a href="#">Reflow Profile</a> .
<a href="#">6.3.1</a>	Added tape and reel dimensions.
<a href="#">6.3.1.1</a>	Added <a href="#">Figure 48</a> .

Preceding document: "BGS2-E/BGS2-W Hardware Interface Description" Version 00.100

New document: "BGS2-E/BGS2-W Hardware Interface Description" Version 00.100a

Chapter	What is new
<a href="#">3.16</a>	Revised RING0 behavior.
<a href="#">6.1</a>	Updated <a href="#">Figure 43</a> .

New document: "BGS2-E/BGS2-W Hardware Interface Description" Version 00.100

Chapter	What is new
--	Initial document setup.

# 1 Introduction

This document<sup>1</sup> describes the hardware of the Cinterion BGS2-E/BGS2-W module that connects to the cellular device application and the air interface. It helps you quickly retrieve interface specifications, electrical and mechanical details and information on the requirements to be considered for integrating further components.

## 1.1 Related Documents

- [1] BGS2-E/BGS2-W AT Command Set
- [2] BGS2-E/BGS2-W Release Note
- [3] Application Note 48: SMT Module Integration for BGS2-E/BGS2-W

## 1.2 Terms and Abbreviations

Abbreviation	Description
ADC	Analog-to-digital converter
AGC	Automatic Gain Control
ANSI	American National Standards Institute
ARFCN	Absolute Radio Frequency Channel Number
ARP	Antenna Reference Point
ASC0/ASC1	Asynchronous Controller. Abbreviations used for first and second serial interface of BGS2-E/BGS2-W
B	Thermistor Constant
BER	Bit Error Rate
BTS	Base Transceiver Station
CB or CBM	Cell Broadcast Message
CE	Conformité Européene (European Conformity)
CHAP	Challenge Handshake Authentication Protocol
CPU	Central Processing Unit
CS	Coding Scheme
CSD	Circuit Switched Data
CTS	Clear to Send
DAC	Digital-to-Analog Converter
DAI	Digital Audio Interface
dBm0	Digital level, 3.14dBm0 corresponds to full scale, see ITU G.711, A-law
DCE	Data Communication Equipment (typically modems, e.g. Cinterion GSM module)

1. The document is effective only if listed in the appropriate Release Notes as part of the technical documentation delivered with your Cinterion product.

Abbreviation	Description
DCS 1800	Digital Cellular System, also referred to as PCN
DRX	Discontinuous Reception
DSB	Development Support Box
DSP	Digital Signal Processor
DSR	Data Set Ready
DTE	Data Terminal Equipment (typically computer, terminal, printer or, for example, GSM application)
DTR	Data Terminal Ready
DTX	Discontinuous Transmission
EFR	Enhanced Full Rate
EGSM	Enhanced GSM
EIRP	Equivalent Isotropic Radiated Power
EMC	Electromagnetic Compatibility
ERP	Effective Radiated Power
ESD	Electrostatic Discharge
ETS	European Telecommunication Standard
FCC	Federal Communications Commission (U.S.)
FDMA	Frequency Division Multiple Access
FR	Full Rate
GMSK	Gaussian Minimum Shift Keying
GPIO	General Purpose Input/Output
GPRS	General Packet Radio Service
GSM	Global Standard for Mobile Communications
HiZ	High Impedance
HR	Half Rate
I/O	Input/Output
IC	Integrated Circuit
IMEI	International Mobile Equipment Identity
ISO	International Standards Organization
ITU	International Telecommunications Union
kbps	kbits per second
LED	Light Emitting Diode
Li-Ion/Li+	Lithium-Ion
Li battery	Rechargeable Lithium Ion or Lithium Polymer battery
Mbps	Mbits per second
MMI	Man Machine Interface
MO	Mobile Originated
MS	Mobile Station (GSM module), also referred to as TE

Abbreviation	Description
MSISDN	Mobile Station International ISDN number
MT	Mobile Terminated
NTC	Negative Temperature Coefficient
OEM	Original Equipment Manufacturer
PA	Power Amplifier
PAP	Password Authentication Protocol
PBCCH	Packet Switched Broadcast Control Channel
PCB	Printed Circuit Board
PCL	Power Control Level
PCM	Pulse Code Modulation
PCN	Personal Communications Network, also referred to as DCS 1800
PCS	Personal Communication System, also referred to as GSM 1900
PDU	Protocol Data Unit
PLL	Phase Locked Loop
PPP	Point-to-point protocol
PSK	Phase Shift Keying
PSU	Power Supply Unit
PWM	Pulse Width Modulation
R&TTE	Radio and Telecommunication Terminal Equipment
RAM	Random Access Memory
RF	Radio Frequency
RMS	Root Mean Square (value)
RoHS	Restriction of the use of certain hazardous substances in electrical and electronic equipment.
ROM	Read-only Memory
RTC	Real Time Clock
RTS	Request to Send
Rx	Receive Direction
SAR	Specific Absorption Rate
SAW	Surface Accoustic Wave
SELV	Safety Extra Low Voltage
SIM	Subscriber Identification Module
SMD	Surface Mount Device
SMS	Short Message Service
SMT	Surface Mount Technology
SRAM	Static Random Access Memory
TA	Terminal adapter (e.g. GSM module)
TDMA	Time Division Multiple Access

---

<b>Abbreviation</b>	<b>Description</b>
TE	Terminal Equipment, also referred to as DTE
Tx	Transmit Direction
UART	Universal asynchronous receiver-transmitter
URC	Unsolicited Result Code
USSD	Unstructured Supplementary Service Data
VSWR	Voltage Standing Wave Ratio

## 1.3 Regulatory and Type Approval Information

### 1.3.1 Directives and Standards

BGS2-E/BGS2-W is designed to comply with the directives and standards listed below.

It is the responsibility of the application manufacturer to ensure compliance of the final product with all provisions of the applicable directives and standards as well as with the technical specifications provided in the "BGS2-E/BGS2-W Hardware Interface Description".<sup>1</sup>

**Table 1:** Directives

1999/05/EC	Directive of the European Parliament and of the council of 9 March 1999 on radio equipment and telecommunications terminal equipment and the mutual recognition of their conformity (in short referred to as R&TTE Directive 1999/5/EC). The product is labeled with the CE conformity mark <b>CE 0682</b>
2002/95/EC	Directive of the European Parliament and of the Council of 27 January 2003 on the restriction of the use of certain hazardous substances in electrical and electronic equipment (RoHS) 

**Table 2:** Standards of North American type approval<sup>1</sup>

CFR Title 47	Code of Federal Regulations, Part 22 and Part 24 (Telecommunications, PCS); US Equipment Authorization FCC
UL 60 950-1	Product Safety Certification (Safety requirements) 
NAPRD.03 V5.6	Overview of PCS Type certification review board Mobile Equipment Type Certification and IMEI control PCS Type Certification Review board (PTCRB)
RSS132 (Issue2) RSS133 (Issue5)	Canadian Standard

1. Applies for the quad band module variant BGS2-W only.

**Table 3:** Standards of European type approval

3GPP TS 51.010-1	Digital cellular telecommunications system (Phase 2); Mobile Station (MS) conformance specification
ETSI EN 301 511 V9.0.2	Candidate Harmonized European Standard (Telecommunications series) Global System for Mobile communications (GSM); Harmonized standard for mobile stations in the GSM 900 and DCS 1800 bands covering essential requirements under article 3.2 of the R&TTE directive (1999/5/EC) (GSM 13.11 version 7.0.1 Release 1998)
GCF-CC V3.40	Global Certification Forum - Certification Criteria

1. Manufacturers of applications which can be used in the US shall ensure that their applications have a PTCRB approval. For this purpose they can refer to the PTCRB approval of the respective module.

**Table 3:** Standards of European type approval

ETSI EN 301 489-1 V1.8.1	Candidate Harmonized European Standard (Telecommunications series) Electro Magnetic Compatibility and Radio spectrum Matters (ERM); Electro Magnetic Compatibility (EMC) standard for radio equipment and services; Part 1: Common Technical Requirements
ETSI EN 301 489-7 V1.3.1	Candidate Harmonized European Standard (Telecommunications series) Electro Magnetic Compatibility and Radio spectrum Matters (ERM); Electro Magnetic Compatibility (EMC) standard for radio equipment and services; Part 7: Specific conditions for mobile and portable radio and ancillary equipment of digital cellular radio telecommunications systems (GSM and DCS)
EN 60950-1:2006	Safety of information technology equipment

**Table 4:** Requirements of quality

IEC 60068	Environmental testing
DIN EN 60529	IP codes

**Table 5:** Standards of the Ministry of Information Industry of the People's Republic of China

SJ/T 11363-2006	"Requirements for Concentration Limits for Certain Hazardous Substances in Electronic Information Products" (2006-06).
SJ/T 11364-2006	<p>"Marking for Control of Pollution Caused by Electronic Information Products" (2006-06).</p> <p>According to the "Chinese Administration on the Control of Pollution caused by Electronic Information Products" (ACPEIP) the EPUP, i.e., Environmental Protection Use Period, of this product is 20 years as per the symbol shown here, unless otherwise marked. The EPUP is valid only as long as the product is operated within the operating limits described in the Cinterion Wireless Modules Hardware Interface Description.</p> <p>Please see <a href="#">Table 6</a> for an overview of toxic or hazardous substances or elements that might be contained in product parts in concentrations above the limits defined by SJ/T 11363-2006.</p> 

**Table 6:** Toxic or hazardous substances or elements with defined concentration limits

部件名称 Name of the part	有毒有害物质或元素 Hazardous substances					
	铅 (Pb)	汞 (Hg)	镉 (Cd)	六价铬 (Cr(VI))	多溴联苯 (PBB)	多溴二苯醚 (PBDE)
金属部件 (Metal Parts)	○	○	○	○	○	○
电路模块 (Circuit Modules)	X	○	○	○	○	○
电缆及电缆组件 (Cables and Cable Assemblies)	○	○	○	○	○	○
塑料和聚合物部件 (Plastic and Polymeric parts)	○	○	○	○	○	○

O:  
表示该有毒有害物质在该部件所有均质材料中的含量均在SJ/T11363-2006 标准规定的限量要求以下。  
Indicates that this toxic or hazardous substance contained in all of the homogeneous materials for this part is below the limit requirement in SJ/T11363-2006.

X:  
表示该有毒有害物质至少在该部件的某一均质材料中的含量超出SJ/T11363-2006标准规定的限量要求。  
Indicates that this toxic or hazardous substance contained in at least one of the homogeneous materials used for this part *might exceed* the limit requirement in SJ/T11363-2006.



### 1.3.2 SAR requirements specific to portable mobiles

Mobile phones, PDAs or other portable transmitters and receivers incorporating a GSM module must be in accordance with the guidelines for human exposure to radio frequency energy. This requires the Specific Absorption Rate (SAR) of portable BGS2-E/BGS2-W based applications to be evaluated and approved for compliance with national and/or international regulations.

Since the SAR value varies significantly with the individual product design manufacturers are advised to submit their product for approval if designed for portable use. For European and US markets the relevant directives are mentioned below. It is the responsibility of the manufacturer of the final product to verify whether or not further standards, recommendations or directives are in force outside these areas.

*Products intended for sale on US markets<sup>1</sup>*

ES 59005/ANSI C95.1 Considerations for evaluation of human exposure to Electromagnetic Fields (EMFs) from Mobile Telecommunication Equipment (MTE) in the frequency range 30MHz - 6GHz

*Products intended for sale on European markets*







EN 50360 Product standard to demonstrate the compliance of mobile phones with the basic restrictions related to human exposure to electromagnetic fields (300MHz - 3GHz)

---

1. Applies for the quad band module variant BGS2-W only.

### 1.3.3 Safety Precautions

The following safety precautions must be observed during all phases of the operation, usage, service or repair of any cellular terminal or mobile incorporating BGS2-E/BGS2-W. Manufacturers of the cellular terminal are advised to convey the following safety information to users and operating personnel and to incorporate these guidelines into all manuals supplied with the product. Failure to comply with these precautions violates safety standards of design, manufacture and intended use of the product. Cinterion Wireless Modules assumes no liability for customer's failure to comply with these precautions.

	<p>When in a hospital or other health care facility, observe the restrictions on the use of mobiles. Switch the cellular terminal or mobile off, if instructed to do so by the guidelines posted in sensitive areas. Medical equipment may be sensitive to RF energy. The operation of cardiac pacemakers, other implanted medical equipment and hearing aids can be affected by interference from cellular terminals or mobiles placed close to the device. If in doubt about potential danger, contact the physician or the manufacturer of the device to verify that the equipment is properly shielded. Pacemaker patients are advised to keep their hand-held mobile away from the pacemaker, while it is on.</p>
	<p>Switch off the cellular terminal or mobile before boarding an aircraft. Make sure it cannot be switched on inadvertently. The operation of wireless appliances in an aircraft is forbidden to prevent interference with communications systems. Failure to observe these instructions may lead to the suspension or denial of cellular services to the offender, legal action, or both.</p>
	<p>Do not operate the cellular terminal or mobile in the presence of flammable gases or fumes. Switch off the cellular terminal when you are near petrol stations, fuel depots, chemical plants or where blasting operations are in progress. Operation of any electrical equipment in potentially explosive atmospheres can constitute a safety hazard.</p>
	<p>Your cellular terminal or mobile receives and transmits radio frequency energy while switched on. Remember that interference can occur if it is used close to TV sets, radios, computers or inadequately shielded equipment. Follow any special regulations and always switch off the cellular terminal or mobile wherever forbidden, or when you suspect that it may cause interference or danger.</p>
	<p>Road safety comes first! Do not use a hand-held cellular terminal or mobile when driving a vehicle, unless it is securely mounted in a holder for speakerphone operation. Before making a call with a hand-held terminal or mobile, park the vehicle. Speakerphones must be installed by qualified personnel. Faulty installation or operation can constitute a safety hazard.</p>
	<p><b>IMPORTANT!</b> Cellular terminals or mobiles operate using radio signals and cellular networks. Because of this, connection cannot be guaranteed at all times under all conditions. Therefore, you should never rely solely upon any wireless device for essential communications, for example emergency calls. Remember, in order to make or receive calls, the cellular terminal or mobile must be switched on and in a service area with adequate cellular signal strength. Some networks do not allow for emergency calls if certain network services or phone features are in use (e.g. lock functions, fixed dialing etc.). You may need to deactivate those features before you can make an emergency call. Some networks require that a valid SIM card be properly inserted in the cellular terminal or mobile.</p>

## 2 Product Concept

### 2.1 Key Features at a Glance

Feature	Implementation
<i>General</i>	
Frequency bands	Dual band (BGS2-E): GSM 900/1800MHz Quad band (BGS2-W): GSM 850/900/1800/1900MHz
GSM class	Small MS
Output power (according to Release 99, V5)	Class 4 (+33dBm $\pm$ 2dB) for EGSM850 (quad band only) Class 4 (+33dBm $\pm$ 2dB) for EGSM900 Class 1 (+30dBm $\pm$ 2dB) for GSM1800 Class 1 (+30dBm $\pm$ 2dB) for GSM1900 (quad band only)
Power supply	3.3V to 4.5V
Operating temperature (board temperature)	Normal operation: -30°C to +85°C Restricted operation: -40°C to -30°C, +85°C to +90°C
Physical	Dimensions: 27.6mm x 18.8mm x 2.7mm Weight: approx. 3 g
RoHS	All hardware components fully compliant with EU RoHS Directive
<i>GSM/GPRS features</i>	
Data transfer	GPRS: <ul style="list-style-type: none"> <li>• Multislot Class 8 (dual band) or 10 (quad band)</li> <li>• Full PBCCH support</li> <li>• Mobile Station Class B</li> <li>• Coding Scheme 1 – 4</li> </ul> CSD: <ul style="list-style-type: none"> <li>• V.110, RLP, non-transparent</li> <li>• 2.4, 4.8, 9.6, 14.4kbps</li> <li>• USSD</li> </ul> PPP-stack for GPRS data transfer
SMS	Point-to-point MT and MO Cell broadcast Text and PDU mode Storage: SIM card plus 25 SMS locations in mobile equipment Transmission of SMS alternatively over CSD or GPRS. Preferred mode can be user defined.
Fax	Group 3; Class 1
Audio	Speech codecs: <ul style="list-style-type: none"> <li>• Half rate HR (ETS 06.20)</li> <li>• Full rate FR (ETS 06.10)</li> <li>• Enhanced full rate EFR (ETS 06.50/06.60/06.80)</li> <li>• Adaptive Multi Rate AMR</li> </ul> Handsfree operation, echo cancellation, noise suppression, 7 different ringing tones/melodies

Feature	Implementation
<i>Software</i>	
AT commands	Hayes 3GPP TS 27.007, TS 27.005, Cinterion AT commands for RIL compatibility
Microsoft™ compatibility	RIL for Pocket PC and Smartphone
SIM Application Toolkit	SAT Release 99
TCP/IP stack	Protocols: TCP server/client, UDP, HTTP, FTP, SMTP, POP3 Access by AT commands
Firmware update	Generic update from host application over ASC0 or ASC1.
<i>Interfaces</i>	
Module interface	Surface mount device with solderable connection pads (SMT application interface). Land grid array (LGA) technology ensures high solder joint reliability and provides the possibility to use an optional module mounting socket. For more information on how to integrate SMT modules see also [3]. This application note comprises chapters on module mounting and application layout issues as well as on additional SMT application development equipment.
2 serial interfaces	ASC0: <ul style="list-style-type: none"> <li>8-wire modem interface with status and control lines, unbalanced, asynchronous</li> <li>Adjustable baud rates: 1,200bps to 230,400bps</li> <li>Autobauding: 1,200bps to 230,400bps</li> <li>Supports RTS0/CTS0 hardware handshake and software XON/XOFF flow control.</li> <li>Multiplex ability according to GSM 07.10 Multiplexer Protocol.</li> </ul> ASC1: <ul style="list-style-type: none"> <li>4-wire, unbalanced asynchronous interface</li> <li>Adjustable baud rates: 1,200bps to 230,400bps</li> <li>Supports RTS1/CTS1 hardware handshake and software XON/XOFF flow control</li> </ul>
Audio	1 analog interface (with microphone feeding)
UICC interface	Supported SIM/USIM cards: 3V, 1.8V External SIM card reader has to be connected via interface connector (note that card reader is not part of BGS2-E/BGS2-W)
GPIO interface	GPIO interface with 10 GPIO lines. The GPIO interface is shared with an I2C interface, LED signalling and PWM functionality.
Antenna	50Ω
<i>Power on/off, Reset</i>	
Power on/off	Switch-on by hardware signal ON Switch-off by AT command (AT^SMSO) Automatic switch-off in case of critical temperature and voltage conditions.
Reset	Orderly shutdown and reset by AT command
<i>Special features</i>	
Real time clock	Timer functions via AT commands
Phonebook	SIM and phone
TTY/CTM support	Integrated CTM modem

## 2.2 BGS2-E/BGS2-W System Overview

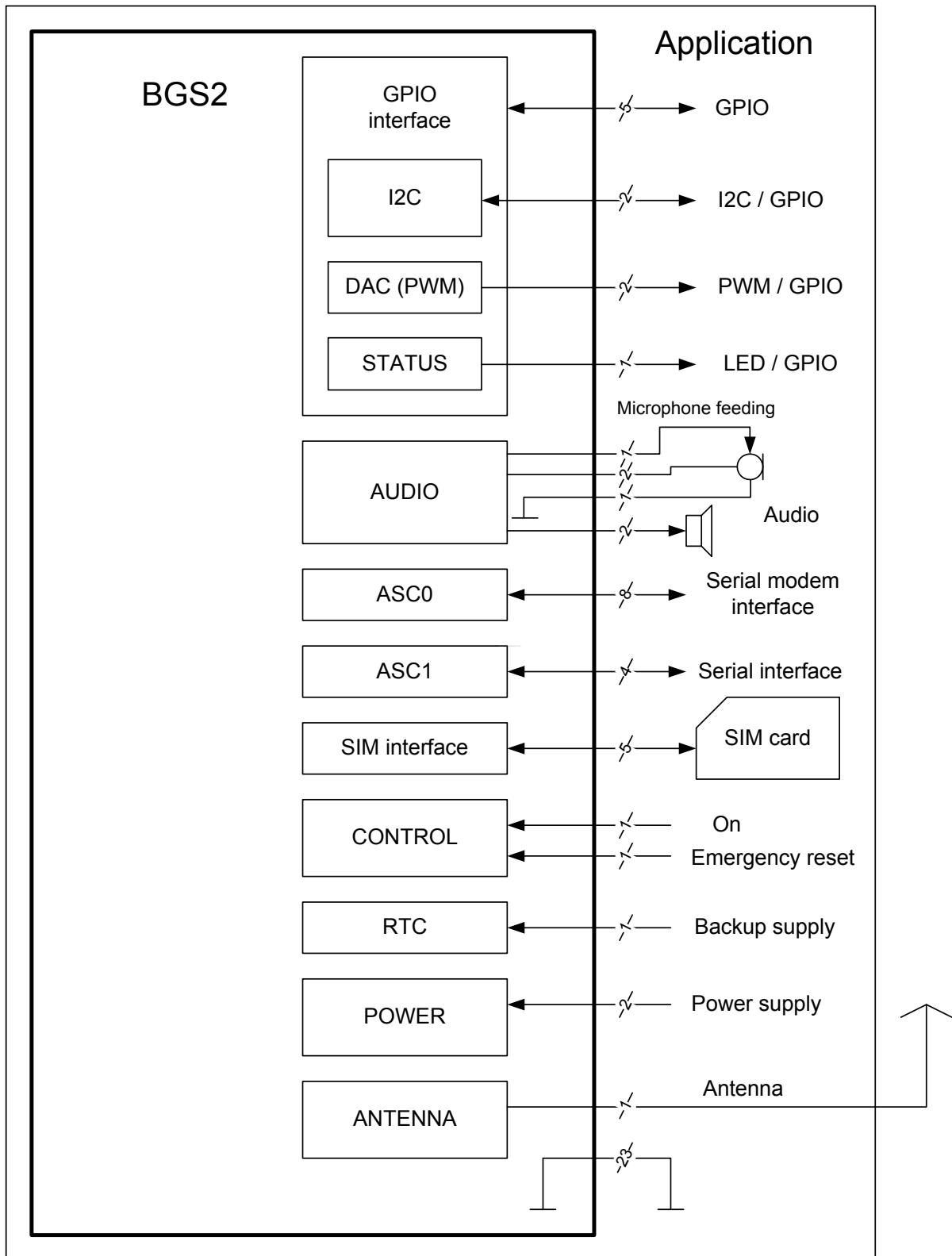

Figure 1: BGS2-E/BGS2-W system overview

## 2.3 Circuit Concept

Figure 2 shows a block diagram of the BGS2-E/BGS2-W module and illustrates the major functional components:

Baseband block:

- GSM baseband processor and power management
- Stacked flash/PSRAM memory
- Application interface (SMT with connecting pads)

GSM RF section:

- RF transceiver (part of baseband processor IC)
- RF power amplifier/front-end module inc. harmonics filtering
- Receive SAW filters

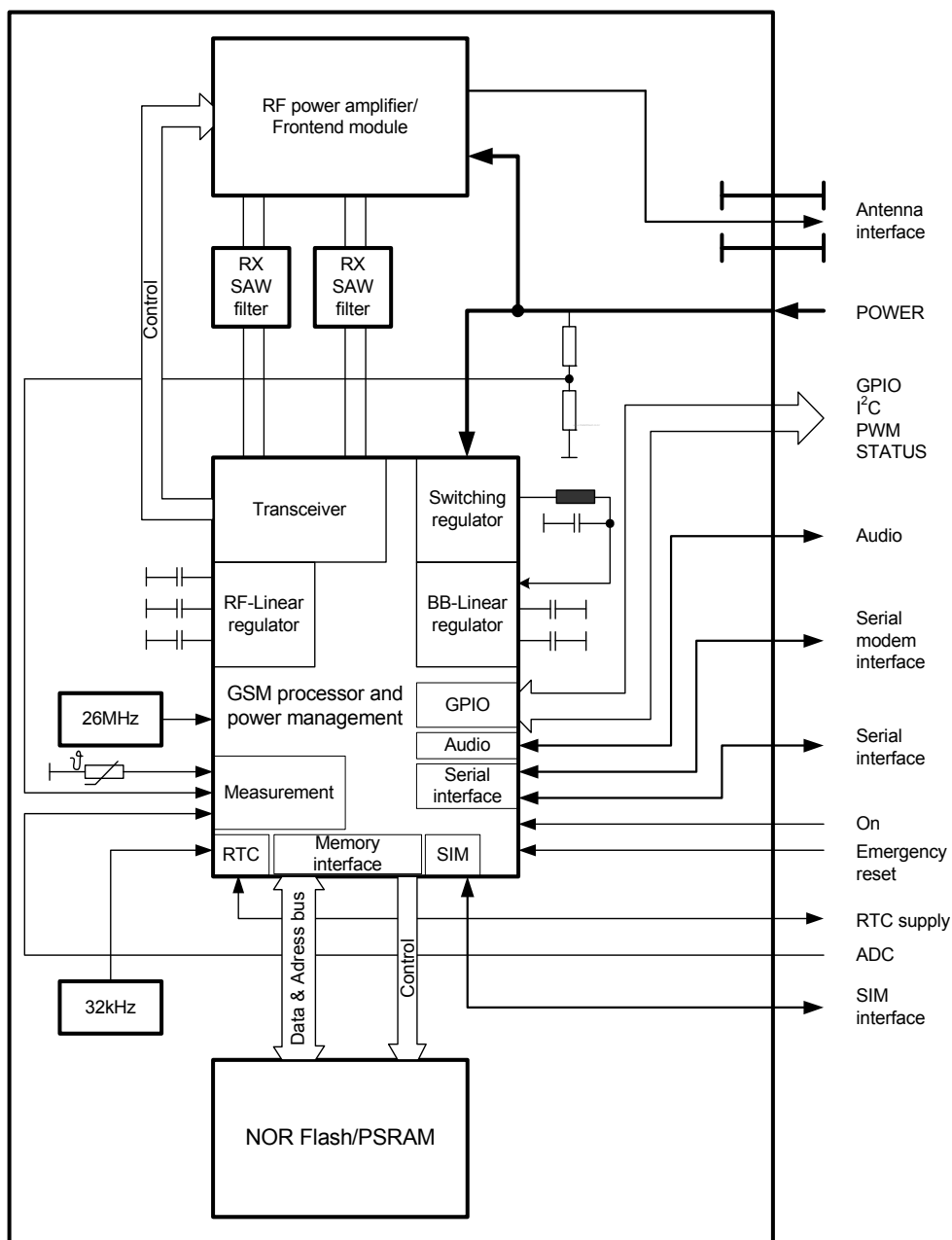

Figure 2: BGS2-E/BGS2-W block diagram

## 3 Application Interface

BGS2-E/BGS2-W is equipped with an SMT application interface that connects to the external application. The host interface incorporates several sub-interfaces described in the following sections:

- Power supply - see [Section 3.2](#)
- RTC backup – see [Section 3.7](#)
- SIM/USIM interface - see [Section 3.8](#)
- Serial interface ASC0 - see [Section 3.9](#)
- Serial interface ASC1 - see [Section 3.10](#)
- Analog audio interface - see [Section 3.11](#)
- GPIO interface - see [Section 3.12](#)
- I<sup>2</sup>C interface - [Section 3.13](#)
- PWM interfaces - [Section 3.14](#)
- Status Control - LED: [Section 3.15](#), RING line: [Section 3.16](#), Power indication: [Section 3.17](#)

### 3.1 Operating Modes

The table below briefly summarizes the various operating modes referred to in the following chapters.

**Table 7:** Overview of operating modes

Normal operation	GSM/GPRS SLEEP	Various power save modes set with AT+CFUN command.  Software is active to minimum extent. If the module was registered to the GSM network in IDLE mode, it is registered and paging with the BTS in SLEEP mode, too. Power saving can be chosen at different levels: The NON-CYCLIC SLEEP mode (AT+CFUN=0) disables the AT interface. The CYCLIC SLEEP modes AT+CFUN=7 and 9 alternately activate and deactivate the AT interfaces to allow permanent access to all AT commands.
	GSM IDLE	Software is active. Once registered to the GSM network, paging with BTS is carried out. The module is ready to send and receive.
	GSM TALK	Connection between two subscribers is in progress. Power consumption depends on network coverage individual settings, such as DTX off/on, FR/EFR/HR, hopping sequences, antenna.
	GPRS IDLE	Module is ready for GPRS data transfer, but no data is currently sent or received. Power consumption depends on network settings and GPRS configuration (e.g. multislot settings).
	GPRS DATA	GPRS data transfer in progress. Power consumption depends on network settings (e.g. power control level), uplink/downlink data rates, GPRS configuration (e.g. used multislot settings) and reduction of maximum output power.
Power Down	Normal shutdown after sending the AT^SMSO command. Only a voltage regulator is active for powering the RTC. Software is not active. Interfaces are not accessible. Operating voltage (connected to BATT+) remains applied.	
Alarm mode	Restricted operation launched by RTC alert function while the module is in Power Down mode. Module will not be registered to GSM network. Limited number of AT commands is accessible.	

See the following sections for the various options of waking up BGS2-E/BGS2-W and proceeding from one mode to another.



## 3.2 Power Supply

BGS2-E/BGS2-W needs to be connected to a power supply at the SMT application interface (2 lines each BATT+ and GND).

The power supply of BGS2-E/BGS2-W has to be a single voltage source at BATT+. It must be able to provide the peak current during the uplink transmission.

All the key functions for supplying power to the device are handled by the power management section of the analog controller. This IC provides the following features:

- Stabilizes the supply voltages for the GSM baseband using low drop linear voltage regulators and a DC-DC step down switching regulator.
- Switches the module's power voltages for the power-up and -down procedures.
- Delivers, across the VEXT line, a regulated voltage for an external application. This voltage is not available in Power-down mode.
- SIM switch to provide SIM power supply.

### 3.2.1 Minimizing Power Losses

When designing the power supply for your application please pay specific attention to power losses. Ensure that the input voltage  $V_{\text{BATT+}}$  never drops below 3.3V on the BGS2-E/BGS2-W board, not even in a GSM transmit burst where current consumption can rise (for peaks values see the power supply ratings listed in [Section 5.5](#)). It should be noted that BGS2-E/BGS2-W switches off when exceeding these limits. Any voltage drops that may occur in a transmit burst should not exceed 400mV.

The module switches off if the minimum battery voltage ( $V_{\text{BattMin}}$ ) is reached.

Example:

$$V_{\text{BattLowLimit}} = 3.3\text{V}$$

$$D_{\text{DropMax}} = 0.4\text{V}$$

$$V_{\text{BattMin}} = V_{\text{BattLowLimit}} + D_{\text{DropMax}}$$

$$V_{\text{BattMin}} = 3.3\text{V} + 0.4\text{V} = 3.7\text{V}$$

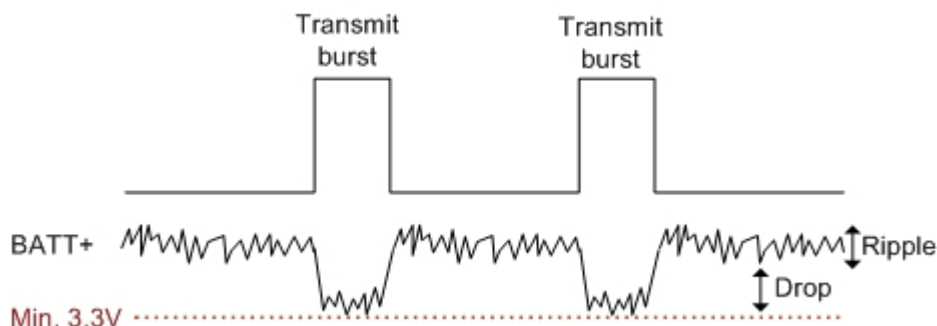

**Figure 3:** Power supply limits during transmit burst

### 3.2.2 Measuring the Supply Voltage ( $V_{\text{BATT+}}$ )

To measure the supply voltage  $V_{\text{BATT+}}$  it is possible to define two reference points GND and BATT+. GND should be the module's shielding, while BATT+ should be a test pad on the external application the module is mounted on. The external BATT+ reference point has to be connected to and positioned close to the SMT application interface's BATT+ pads 5 or 53 as shown in [Figure 4](#).

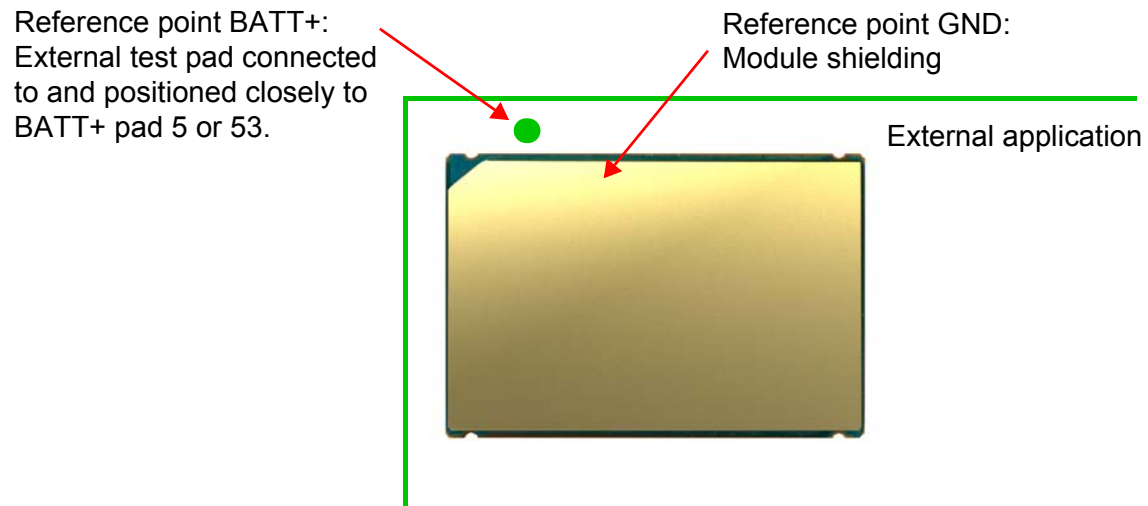

Figure 4: Position of reference points BATT+ and GND

### 3.2.3 Monitoring Power Supply by AT Command

To monitor the supply voltage you can also use the AT<sup>^</sup>SBV command which returns the value related to the reference points BATT+ and GND.

The module continuously measures the voltage at intervals depending on the operating mode of the RF interface. The duration of measuring ranges from 0.5s in TALK/DATA mode to 50s when BGS2-E/BGS2-W is in IDLE mode or Limited Service (deregistered). The displayed voltage (in mV) is averaged over the last measuring period before the AT<sup>^</sup>SBV command was executed.

### 3.3 Power Up/Power Down Scenarios

In general, be sure not to turn on BGS2-E/BGS2-W while it is beyond the safety limits of voltage and temperature stated in [Chapter 5](#). BGS2-E/BGS2-W would immediately switch off after having started and detected these inappropriate conditions. In extreme cases this can cause permanent damage to the module.

#### 3.3.1 Turn on BGS2-E/BGS2-W

BGS2-E/BGS2-W can be started as described in the following sections:

- Hardware driven switch on by ON line: Starts Normal mode (see [Section 3.3.1.1](#)).
- Wake-up from Power Down mode by using RTC interrupt: Starts Alarm mode (see [Section 3.3.1.3](#)).

##### 3.3.1.1 Switch on BGS2-E/BGS2-W Using ON Signal

When the operating voltage BATT+ is applied, BGS2-E/BGS2-W can be switched on by means of the ON signal.

If the operating voltage BATT+ is applied while the ON signal is present, BGS2-E/BGS2-W will be switched on automatically. Please note that if the rise time for the operating voltage BATT+ is longer than 12ms, the module startup will be delayed by about 1 second.

Please also note that if there is no ON signal present right after applying BATT+, BGS2-E/BGS2-W will instead of switching on perform a very short switch on/off sequence (approx. 120ms) that cannot be avoided.

The ON signal is a high active signal and only allows the input voltage level of the VDDL P signal. The following [Figure 5](#) shows an example for a switch-on circuit (an alternative switch-on possibility is shown in [Figure 57](#)).

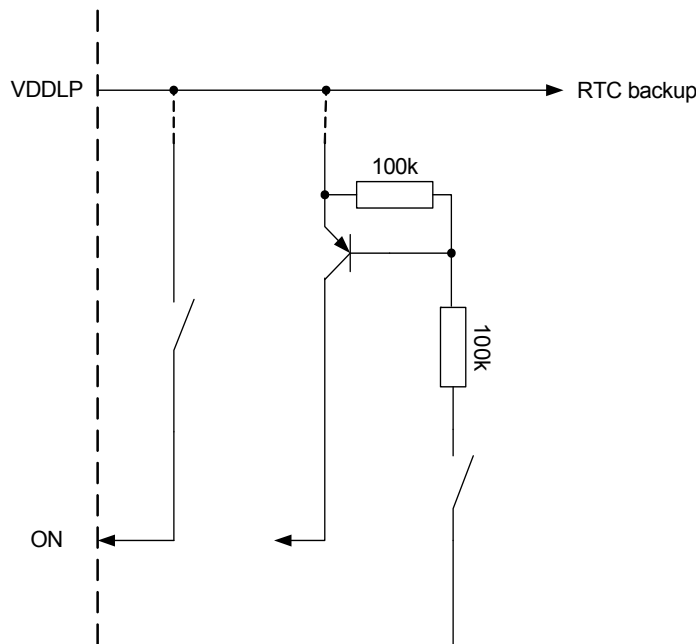

Figure 5: ON circuit sample

It is recommended to set a serial 1kOhm resistor between the ON circuit and the external capacitor or battery at the VDDLp power supply. This serial resistor protection is necessary in case the capacitor or battery has low power (is empty).

Please note that the ON signal is an edge triggered signal. This implies that a micro-second high pulse on the signal line suffices to almost immediately switch on the module, as shown in Figure 6. The following Section 3.3.1.2 describes a sample circuit that may be implemented to prevent possible spikes or glitches on the ON signal line from unintentionally switching on the module.

Please also note that if the state of the ON signal is coupled to the state of the VDDLp line or that if the ON signal otherwise remains active high after switch on, it is no longer possible to switch off BGS2-E/BGS2-W using the AT command AT^SMSO. Using this command will instead automatically restart the module.

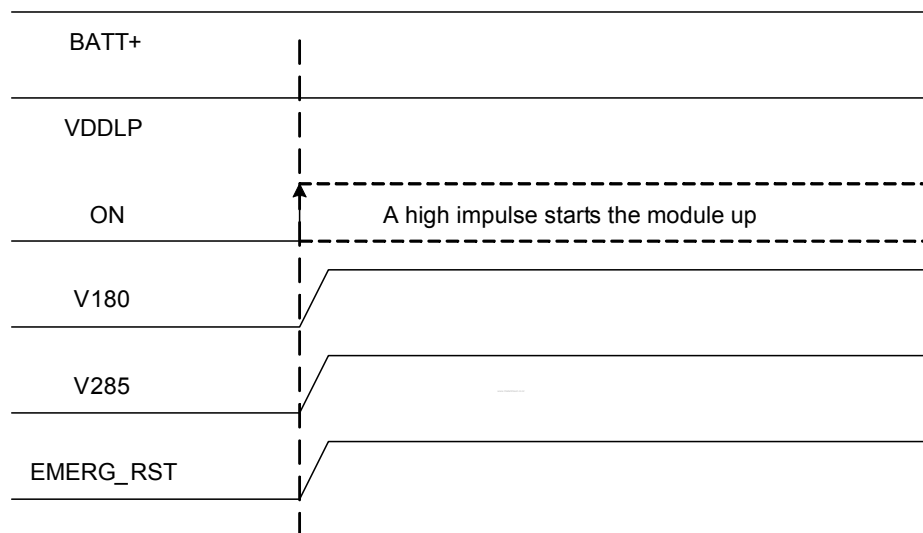

Figure 6: ON timing

If configured to a fixed bit rate (AT+IPR≠0), the module will send the URC “^SYSSTART” which notifies the host application that the first AT command can be sent to the module. The duration until this URC is output varies with the SIM card and may take a couple of seconds, particularly if the request for the SIM PIN is deactivated on the SIM card.

Please note that no “^SYSSTART” URC will be generated if autobauding (AT+IPR=0) is enabled.

To allow the application to detect the ready state of the module we recommend using hardware flow control which can be set with AT\Q (see [1] for details). The default setting is AT\Q0 (no flow control) which shall be altered to AT\Q3 (RTS/CTS handshake). If the application design does not integrate RTS/CTS lines the host application shall wait at least for the “^SYSSTART” URC. However, if the URC is not available (due to autobauding), you will simply have to wait for a period of time (at least 2 seconds) before assuming the module to be in ready state and before entering any data.

Please note that no data must be sent over the ASC0 interface before the interface is active and ready to receive data.

### 3.3.1.2 Suppressing Unintentional Pulses on ON Signal Line

Since the ON signal is edge triggered and a microsecond high pulse on the signal line suffices to almost immediately switch on the module, it might be necessary to implement a circuit on the external application that prevents possible spikes or glitches on the signal line from unintentionally switching on the module. [Figure 7](#) shows an example for such a circuit.

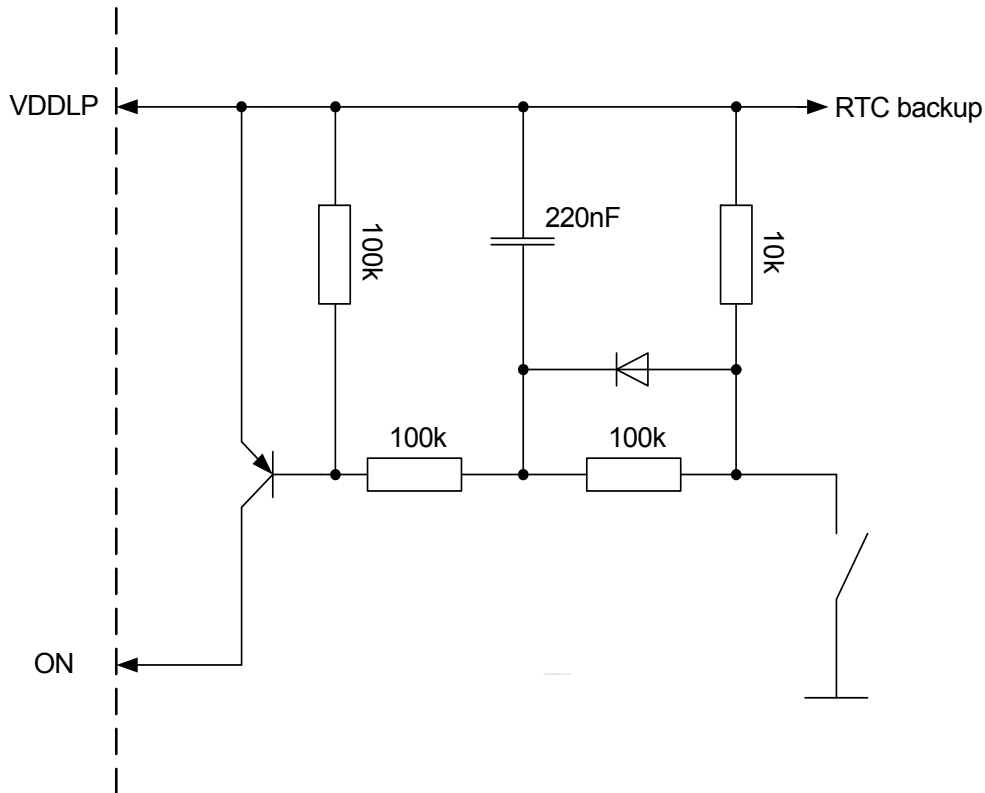

**Figure 7:** Sample circuit to suppress spikes or glitches on ON signal line

### 3.3.1.3 Turn on BGS2-E/BGS2-W Using the RTC (Alarm Mode)

Another power-on approach is to use the RTC, which is constantly supplied with power from a separate voltage regulator in the power supply processor. The RTC provides an alert function, which allows the BGS2-E/BGS2-W to wake up whilst the internal voltage regulators are off. This procedure only enables restricted operation, referred to as Alarm mode. It must not be confused with a reminder message that can be activated by using the same AT command, but without switching off power.

Use the AT+CALA command to set the alarm time. The RTC retains the alarm time if BGS2-E/BGS2-W was powered down by AT^SMSO. Once the alarm is timed out and executed, BGS2-E/BGS2-W enters Alarm mode. This is indicated by an Unsolicited Result Code (URC) which reads:

```
^SYSSTART ALARM MODE
```

Note that this URC is the only indication of the Alarm mode and will not appear when autobauding AT+IPR=0 was activated (due to the missing synchronization between DTE and DCE upon start-up). Therefore, it is recommended to select a fixed baudrate before using the Alarm mode.

In Alarm mode the module is deregistered from the GSM network and only a limited number of AT commands is available. For a table showing the availability of AT commands depending on the module's operating mode please refer to [1].

For the module to change from Alarm mode to full operation (normal operating mode) it is possible to use the AT+CFUN command or to switch on the module using the ON signal. The latter must be implemented in your host application as described in [Section 3.3.1.1](#).

## 3.3.2 Restart BGS2-E/BGS2-W

After startup BGS2-E/BGS2-W can be re-started as described in the following sections:

- Software controlled reset by AT+CFUN command: Starts Normal mode (see [Section 3.3.2.1](#)).
- Hardware controlled reset by EMERG\_RST line: Starts Normal mode (see [Section 3.3.2.2](#))

### 3.3.2.1 Restart BGS2-E/BGS2-W via AT+CFUN Command

To reset and restart the BGS2-E/BGS2-W module use the command AT+CFUN. You can enter the command AT+CFUN=,1 or 1,1 or 7,1 or 9,1. See [1] for details.

If configured to a fix baud rate (AT+IPR≠0), the module will send the URC "^SYSSTART" to notify that it is ready to operate. If autobauding is enabled (AT+IPR=0) there will be no notification. To register to the network SIM PIN authentication is necessary after restart.

### 3.3.2.2 Restart BGS2-E/BGS2-W Using EMERG\_RST

The EMERG\_RST signal is internally connected to the central GSM processor. A low level for more than 10ms sets the processor and with it all the other signal pads to their respective reset state. The reset state is described in Section 3.3.3 as well as in the figures showing the startup behavior of an interface.

After releasing the EMERG-RST line, i.e., with a change of the signal level from low to high, the module restarts. The other signals continue from their reset state as if the module was switched on by the ON signal.

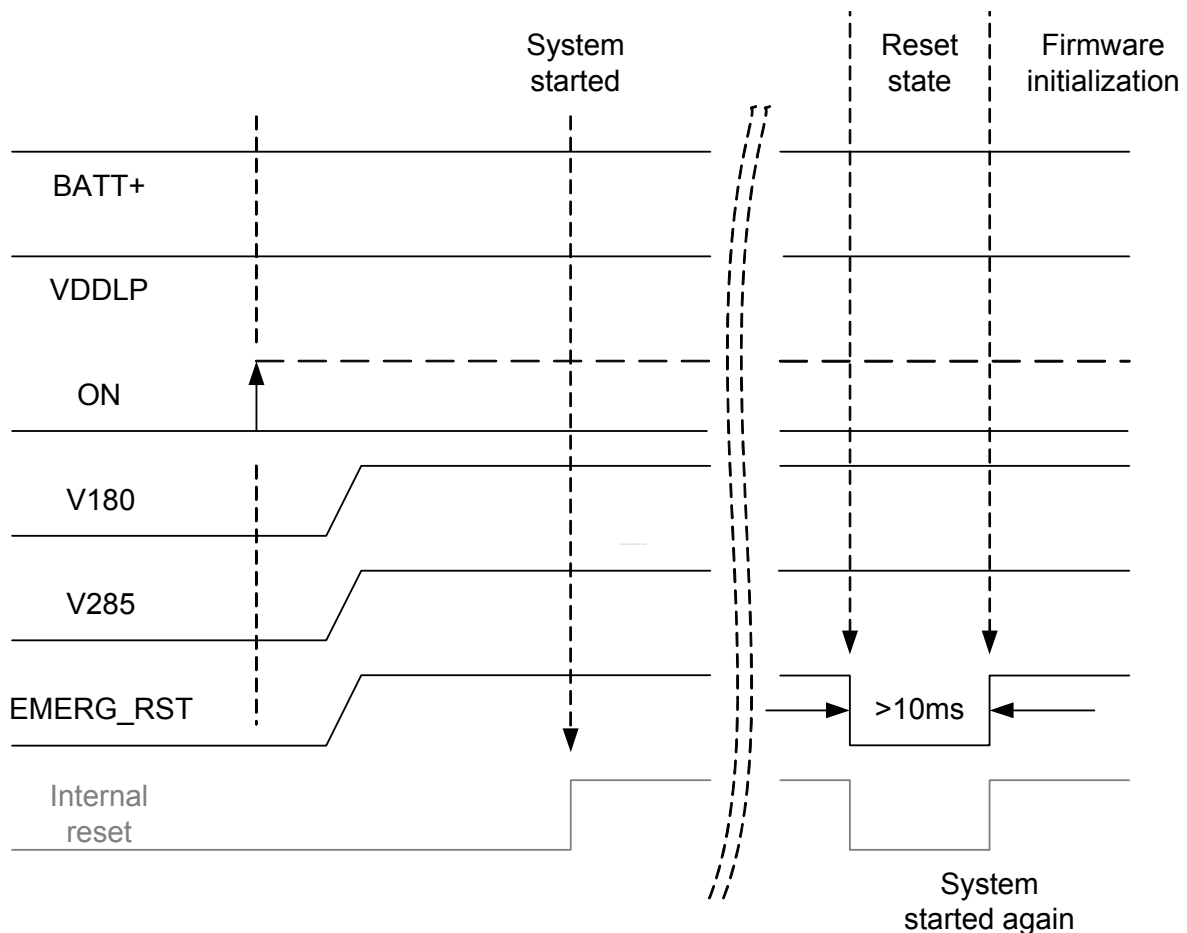

Figure 8: Emergency restart timing

It is recommended to control this EMERG\_RST line with an open collector transistor or an open drain field-effect transistor.

*Caution: Use the EMERG\_RST line only when, due to serious problems, the software is not responding for more than 5 seconds. Pulling the EMERG\_RST line causes the loss of all information stored in the volatile memory. Therefore, this procedure is intended only for use in case of emergency, e.g. if BGS2-E/BGS2-W does not respond, if reset or shutdown via AT command fails.*

### 3.3.3 Signal States after Startup

Table 8 lists the states each interface signal passes through during reset and firmware initialization.

The reset state is reached with the rising edge of the EMERG\_RST signal - either after a normal module startup (see Section 3.3.1.1) or after a reset (see Section 3.3.2.2). After the reset state has been reached the firmware initialization state begins. The firmware initialization is completed as soon as the ASC0 interface lines CTS0, DSR0 and RING0 as well as the ASC1 interface line CTS1 have turned low (see Section 3.9 and Section 3.10). Now, the module is ready to receive and transmit data.

**Table 8:** Signal states

Signal name	Reset state	Firmware initialization
CCIN	T / 100k PD	I / 100k PD
CCRST	L	O / L
CCIO	L	O / L
CCCLK	L	O / L
CCVCC	T / PU_B	O / L
RXD0	T / 2 x PU_A	O / H
TXD0	T / 2 x PU_A	I
CTS0	PD_B	O / H
RTS0	T / 10k PU	I / 10k PU
RING0	T / 10k PU	O / H, 10k PU
DTR0	T / PD_A	T / PD_A
DCD0	T / PU_A	T / PU_A
DSR0	T / PD_C	T / PD_C
RXD1	T / PD_B	O / H
TXD1	T / PD_B	I
CTS1	T / PD_B	O / H
RTS1	T / PU_A	I / PU_A
GPIO1	T / PU_B	T / PU_B
GPIO2	T / PU_B	T / PU_B
GPIO3	T / PU_B	T / PU_B
GPIO4	T / PU_A	T / PU_A
GPIO5 / LED	T / PU_A	T / PU_A
GPIO6 / PWM2	T / PU_B	T / PU_B
GPIO7 / PWM1	T / PU_B	T / PU_B
GPIO8	T / PU_B	T / PU_B
GPIO9 / I2CDAT	T / OD	T / OD
GPIO10 / I2CCLK	T / 5k PU / OD	T / 5k PU / OD



Abbreviations used in above [Table 8](#):

L = Low level	OD = Open Drain
H = High level	PD_A = Pull down, 103 $\mu$ A at 1.75V
L/H = Low or high level	PD_B = Pull down, 51 $\mu$ A at 1.75V
T = Tristate	PD_C = Pull down, 27 $\mu$ A at 1.75V
I = Input	PU_A = Pull up -102 $\mu$ A at 0.05V
O = Output	PU_B = Pull up -55 $\mu$ A at 0.05V
	PU_C = Pull up -31 $\mu$ A at 0.05V

### 3.3.4 Turn off BGS2-E/BGS2-W

To switch the module off the following procedures may be used:

- *Normal shutdown procedure:* Software controlled by sending the AT<sup>^</sup>SMSO command over the serial application interface. See [Section 3.3.4.1](#).
- *Automatic shutdown:* See [Section 3.3.5](#)
  - Takes effect if under- or overvoltage is detected.
  - Takes effect if BGS2-E/BGS2-W board temperature exceeds a critical limit.

#### 3.3.4.1 Switch off BGS2-E/BGS2-W Using AT Command

The best and safest approach to powering down BGS2-E/BGS2-W is to issue the AT<sup>^</sup>SMSO command. This procedure lets BGS2-E/BGS2-W log off from the network and allows the software to enter into a secure state and save data before disconnecting the power supply. The mode is referred to as Power Down mode. In this mode, only the RTC stays active.

Before switching off the device sends the following response:

```
^SMSO: MS OFF
```

```
OK
```

```
^SHUTDOWN
```

After sending AT<sup>^</sup>SMSO do not enter any other AT commands. There are two ways to verify when the module turns off:

- Wait for the URC “^SHUTDOWN”. It indicates that data have been stored non-volatile and the module turns off in less than 1 second.
- Also, you can monitor the V180/V285 pads. The low state of these pads definitely indicates that the module is switched off.

Be sure not to disconnect the operating voltage  $V_{BATT+}$  before the URC “^SHUTDOWN” has been issued and the V180/V285 pads have gone low. Otherwise you run the risk of losing data.

While BGS2-E/BGS2-W is in Power Down mode the application interface is switched off and must not be fed from any other voltage source. Therefore, your application must be designed to avoid any current flow into any digital pads of the application interface.

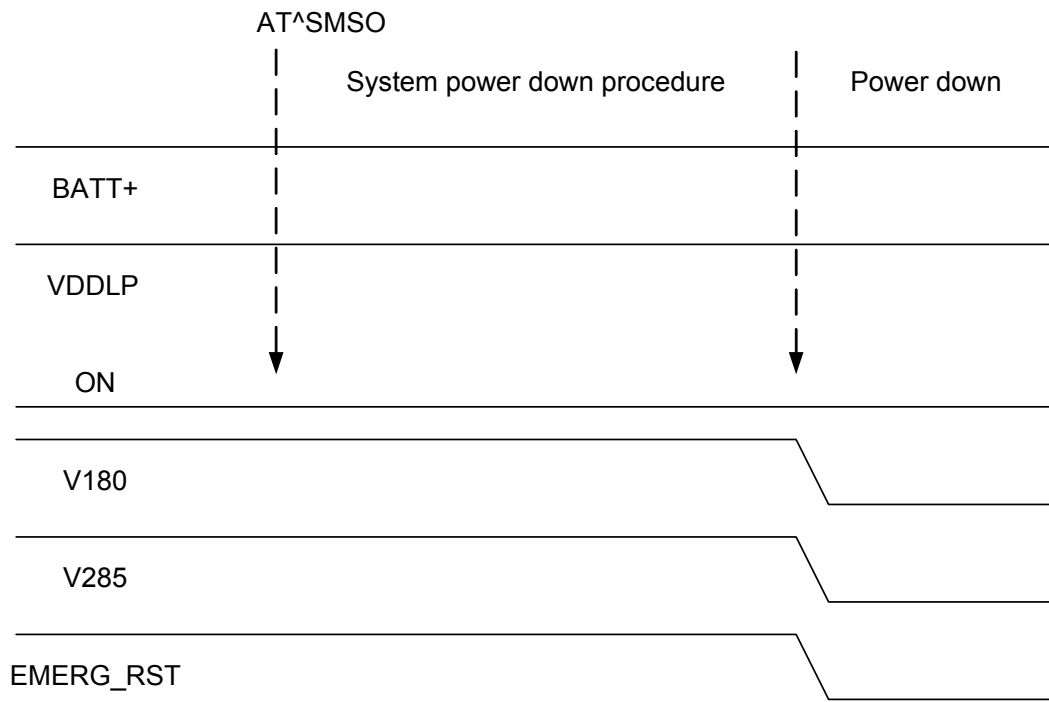

Figure 9: Switch off behavior

### 3.3.5 Automatic Shutdown

Automatic shutdown takes effect if any of the following events occurs:

- the BGS2-E/BGS2-W board is exceeding the critical limits of overtemperature or undertemperature
- undervoltage or overvoltage is detected

The automatic shutdown procedure is equivalent to the power-down initiated with the AT^SMSO command, i.e. BGS2-E/BGS2-W logs off from the network and the software enters a secure state avoiding loss of data.

#### 3.3.5.1 Thermal Shutdown

The board temperature is constantly monitored by an internal NTC resistor located on the PCB. The values detected by the NTC resistor are measured directly on the board and therefore, are not fully identical with the ambient temperature.

Each time the board temperature goes out of range or back to normal, BGS2-E/BGS2-W instantly displays an alert (if enabled).

- URCs indicating the level "1" or "-1" allow the user to take appropriate precautions, such as protecting the module from exposure to extreme conditions. The presentation of the URCs depends on the settings selected with the AT^SCTM write command (for details see [1]):  
 AT^SCTM=1: Presentation of URCs is always enabled.  
 AT^SCTM=0 (default): Presentation of URCs is enabled during the 15 second guard period after start-up of BGS2-E/BGS2-W. After expiry of the 15 second guard period, the presentation will be disabled, i.e. no URCs with alert levels "1" or "-1" will be generated.
- URCs indicating the level "2" or "-2" are instantly followed by an orderly shutdown. The presentation of these URCs is always enabled, i.e. they will be output even though the factory setting AT^SCTM=0 was never changed.

The maximum temperature ratings are stated in Section 5.2. Refer to Table 9 for the associated URCs.

**Table 9:** Temperature dependent behavior

Sending temperature alert (15s after BGS2-E/BGS2-W startup, otherwise only if URC presentation enabled)	
^SCTM_B: 1	Board close to overtemperature limit.
^SCTM_B: -1	Board close to undertemperature limit.
^SCTM_B: 0	Board back to non-critical temperature range.
Automatic shutdown (URC appears no matter whether or not presentation was enabled)	
^SCTM_B: 2	Alert: Board equal or beyond overtemperature limit. BGS2-E/BGS2-W switches off.
^SCTM_B: -2	Alert: Board equal or below undertemperature limit. BGS2-E/BGS2-W switches off.

### 3.3.5.2 Undervoltage Shutdown

If the measured supply voltage is no more sufficient to set up a call the following URC will be presented:

^SBC: Undervoltage.

The message will be reported, for example, when you attempt to make a call while the voltage is close to the shutdown threshold of 3.3V and further power loss is caused during the transmit burst. In an idle state, the shutdown threshold is the sum of the module's minimum supply voltage (3.3V) and the value of the maximum voltage drop resulting from earlier calls. This means that in an idle state the actual shutdown threshold may be higher than 3.3V. Therefore, to properly calculate the actual shutdown threshold application manufacturers are advised to measure the maximum voltage drops that may occur during transmit bursts.

This type of URC does not need to be activated by the user. It will be output automatically when fault conditions occur.

### 3.3.5.3 Overvoltage Shutdown

The overvoltage shutdown threshold is 100mV above the maximum supply voltage  $V_{BATT+}$  specified in [Table 24](#).

When the supply voltage approaches the overvoltage shutdown threshold the module will send the following URC:

^SBC: Overvoltage

This alert is sent once.

When the overvoltage shutdown threshold is exceeded the module will shut down cleanly.

This type of URC does not need to be activated by the user. It will be output automatically when fault conditions occur.

Keep in mind that several BGS2-E/BGS2-W components are directly linked to BATT+ and, therefore, the supply voltage remains applied at major parts of BGS2-E/BGS2-W. Especially the power amplifier is very sensitive to high voltage and might even be destroyed.

### 3.4 Automatic GPRS Multislot Class Change

Please note that automatic GPRS multislot class change applies only for the quad band module variant BGS2-W:

Temperature control is also effective for operation in GPRS Multislot Class 10. If the board temperature increases to the limit specified for restricted operation (see [Section 5.2](#) for temperature limits) while data is transmitted over GPRS, the module automatically reverts from GPRS Multislot Class 10 (2Tx) to Class 8 (1Tx). This reduces the power consumption and, consequently, causes the board's temperature to decrease. Once the temperature drops to a value of 5 degrees below the limit of restricted operation, BGS2-W returns to the higher Multislot Class. If the temperature stays at the critical level or even continues to rise, BGS2-W will not switch back to the higher class.

After a transition from Multislot Class 10 to Multislot 8 a possible switchback to Multislot Class 10 is blocked for one minute.

Please note that there is not one single cause of switching over to a lower GPRS Multislot Class. Rather it is the result of an interaction of several factors, such as the board temperature that depends largely on the ambient temperature, the operating mode and the transmit power. Furthermore, take into account that there is a delay until the network proceeds to a lower or, accordingly, higher Multislot Class. The delay time is network dependent. In extreme cases, if it takes too much time for the network and the temperature cannot drop due to this delay, the module may even switch off as described in [Section 3.3.4](#).

## 3.5 Power Saving

SLEEP mode reduces the functionality of the BGS2-E/BGS2-W module to a minimum and, thus, minimizes the current consumption to the lowest level. Settings can be made using the AT+CFUN command. For details see below and [\[1\]](#). SLEEP mode falls into two categories:

- NON-CYCLIC SLEEP mode AT+CFUN=0
- CYCLIC SLEEP modes, selectable with AT+CFUN=7 or 9.

**IMPORTANT:** Please keep in mind that power saving works properly only when PIN authentication has been done. If you attempt to activate power saving while the SIM card is not inserted or the PIN not correctly entered (Limited Service), the selected <fun> level will be set, though power saving does not take effect. For the same reason, power saving cannot be used if BGS2-E/BGS2-W operates in Alarm mode.

To check whether power saving is on, you can query the status of AT+CFUN if you have chosen CYCLIC SLEEP mode.

The wake-up procedures are quite different depending on the selected SLEEP mode. [Table 10](#) compares the wake-up events that can occur in NON-CYCLIC and CYCLIC SLEEP modes.

### 3.5.1 No Power Saving (AT+CFUN=1)

The functionality level <fun>=1 is where power saving is switched off. This is the default after startup.

### 3.5.2 NON-CYCLIC SLEEP Mode (AT+CFUN=0)

If level 0 has been selected (AT+CFUN=0), the serial interface is blocked. The module shortly deactivates power saving to listen to a paging message sent from the base station and then immediately resumes power saving. Level 0 is called NON-CYCLIC SLEEP mode, since the serial interface is not alternatingly made accessible as in CYCLIC SLEEP mode.

The first wake-up event fully activates the module, enables the serial interface and terminates the power saving mode. In short, it takes BGS2-E/BGS2-W back to the highest level of functionality <fun>=1.

In NON-CYCLIC mode, the falling edge of the RTS0 or RTS1 lines wakes up the module to <fun>=1. To efficiently use this feature it is recommended to enable hardware flow control (RTS/CTS handshake) as in this case the CTS line notifies the application when the module is ready to send or receive characters. See [Section 3.5.6.1](#) for details.

### 3.5.3 CYCLIC SLEEP Mode AT+CFUN=7

The functionality level AT+CFUN=7 is referred to as CYCLIC SLEEP modes. The major benefit of all CYCLIC SLEEP modes is that the serial interface remains accessible, and that, in intermittent wake-up periods, characters can be sent or received without terminating the selected mode.

The CYCLIC SLEEP modes give you greater flexibility regarding the wake-up procedures: For example, in all CYCLIC SLEEP modes, you can enter AT+CFUN=1 to permanently wake up the module. In mode CFUN=7, BGS2-E/BGS2-W automatically resumes power saving, after you have sent or received a short message, made a call or completed a GPRS transfer. Please refer to [Table 10](#) for a summary of all modes.

The CYCLIC SLEEP mode is a dynamic process which alternately enables and disables the serial interface. By setting/resetting the CTS signal, the module indicates to the application whether or not the UART is active. The timing of CTS is described below.

Both the application and the module must be configured to use hardware flow control (RTS/CTS handshake). The default setting of BGS2-E/BGS2-W is AT\Q0 (no flow control) which must be altered to AT\Q3. See [\[1\]](#) for details.

*Note: If both serial interfaces ASC0 and ASC1 are connected, both are synchronized. This means that SLEEP mode takes effect on both, no matter on which interface the AT command was issued. Although not explicitly stated, all explanations given in this section refer equally to ASC0 and ASC1, and accordingly to CTS0 and CTS1.*

### 3.5.4 CYCLIC SLEEP Mode AT+CFUN=9

Mode AT+CFUN=9 is similar to AT+CFUN=7, but provides two additional features:

- The time the module stays active after RTS was asserted or after the last character was sent or received, can be configured individually using the command AT^SCFG. Default setting is 2 seconds like in AT+CFUN=7. The entire range is from 0.5 seconds to 1 hour, selectable in tenths of seconds. For details see [\[1\]](#).
- RTS0 and RTS1 are not only used for flow control (as in mode AT+CFUN=7), but also cause the module to wake up temporarily. See [Section 3.5.6.1](#) for details.

### 3.5.5 Timing of the CTS Signal in CYCLIC SLEEP Modes

The CTS signal is enabled in synchrony with the module's paging cycle. It goes active low each time when the module starts listening to a paging message block from the base station. The timing of the paging cycle varies with the base station. The duration of a paging interval can be calculated from the following formula:

$4.616 \text{ ms (TDMA frame duration)} * 51 \text{ (number of frames)} * \text{DRX value.}$

DRX (Discontinuous Reception) is a value from 2 to 9, resulting in paging intervals from 0.47 to 2.12 seconds. The DRX value of the base station is assigned by the network operator.

Each listening period causes the CTS signal to go active low: If DRX is 2, the CTS signal is activated every 0.47 seconds, if DRX is 3, the CTS signal is activated every 0.71 seconds and if DRX is 9, the CTS signal is activated every 2.1 seconds.



The CTS signal is active low for 4.6 ms. This is followed by another 4.6 ms UART activity. If the start bit of a received character is detected within these 9.2 ms, CTS will be activated and the proper reception of the character will be guaranteed. CTS will also be activated if any character is to be sent.

After the last character was sent or received the interface will remain active for

- another 2 seconds, if AT+CFUN=7
- or for an individual time defined with AT^SCFG, if AT+CFUN=9. Assertion of RTS has the same effect.

In the pauses between listening to paging messages, while CTS is high, the module resumes power saving and the AT interface is not accessible. See [Figure 10](#) and [Figure 11](#).

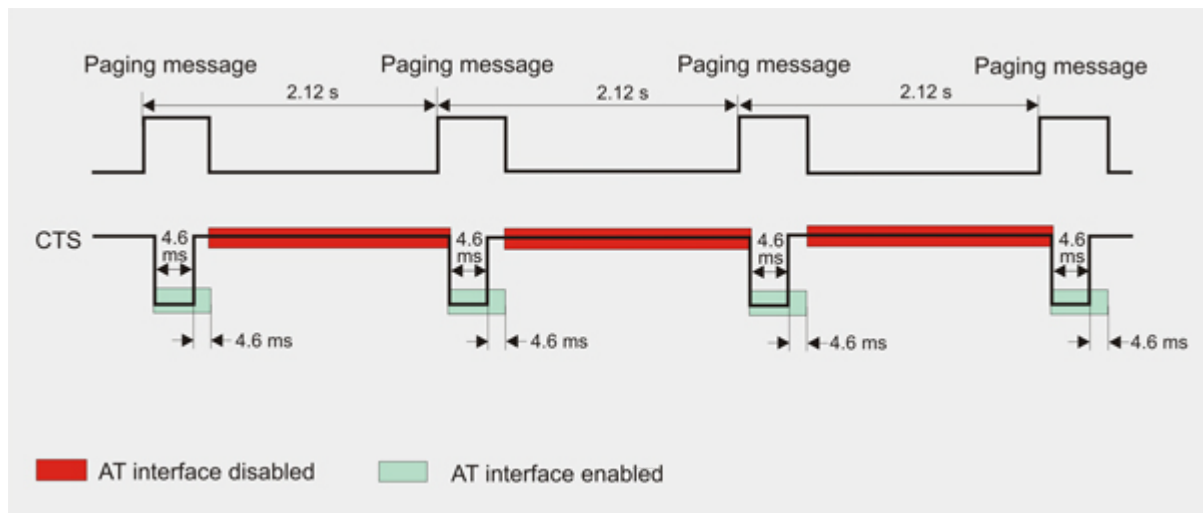

Figure 10: Timing of CTS signal (example for a 2.12 s paging cycle)

[Figure 11](#) illustrates the CFUN=7 modes, which reset the CTS signal 2 seconds after the last character was sent or received.

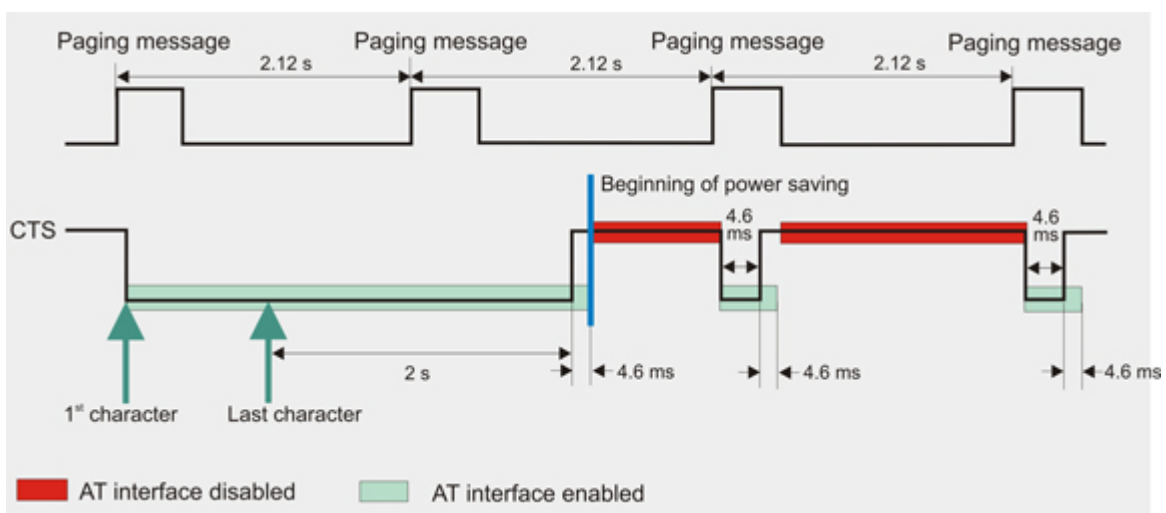

Figure 11: Beginning of power saving if CFUN=7

### 3.5.6 Wake up BGS2-E/BGS2-W from SLEEP Mode

A wake-up event is any event that causes the module to draw current. Depending on the selected mode the wake-up event either switches SLEEP mode off and takes BGS2-E/BGS2-W back to AT+CFUN=1, or activates BGS2-E/BGS2-W temporarily without leaving the current SLEEP mode.

Definitions of the state transitions described in [Table 10](#):

- Quit = BGS2-E/BGS2-W exits SLEEP mode and returns to AT+CFUN=1.  
 Temporary = BGS2-E/BGS2-W becomes active temporarily for the duration of the event and the mode specific follow-up time after the last character was sent or received on the serial interface.  
 No effect = Event is not relevant in the selected SLEEP mode. BGS2-E/BGS2-W does not wake up.

**Table 10:** Wake-up events in NON-CYCLIC and CYCLIC SLEEP modes

Event	Selected mode AT+CFUN=0	Selected mode AT+CFUN=7 or 9
Ignition line	No effect	No effect
RTS0 or RTS1 <sup>1)</sup> (falling edge)	Quit + flow control	Mode 7: No effect, RTS is only used for flow control Mode 9: Temporary + flow control
Unsolicited Result Code (URC)	Quit	Temporary
Incoming voice or data call	Quit	Temporary
Any AT command (incl. outgoing voice or data call, outgoing SMS)	Not possible (UART disabled)	Temporary
Incoming SMS depending on mode selected by AT+CNMI: AT+CNMI=0,0 (= default, no indication of received SMS)	No effect	No effect
AT+CNMI=1,1 (= displays URC upon receipt of SMS)	Quit	Temporary
GPRS data transfer	Not possible (UART disabled)	Temporary
RTC alarm <sup>2)</sup>	Quit	Temporary
AT+CFUN=1	Not possible (UART disabled)	Quit

1. See [Section 3.5.6.1](#) on wake-up via RTS.

2. Recommendation: In NON-CYCLIC SLEEP mode, you can set an RTC alarm to wake up BGS2-E/BGS2-W and return to full functionality. This is a useful approach because, in this mode, the AT interface is not accessible.

### 3.5.6.1 Wake-up via RTS0 and RTS1 (if AT+CFUN=0 or AT+CFUN=9)

During the CYCLIC SLEEP mode 7, the RTS0 and RTS1 lines are conventionally used for flow control: The assertion of RTS0 or RTS1 indicates that the application is ready to receive data - without waking up the module.

If the module is in CFUN=0 mode the assertion of RTS0 and RTS1 serves as a wake-up event, giving the application the possibility to intentionally terminate power saving. If the module is in CFUN=9 mode, the assertion of RTS0 or RTS1 can be used to temporarily wake up BGS2-E/ BGS2-W for the time specified with the AT^SCFG command (default = 2s). In both cases, if RTS0 or RTS1 is asserted while AT+CFUN=0 or AT+CFUN=9 is set, there may be a short delay until the module is able to receive data again. This delay depends on the current module activities (e.g. paging cycle) and may be up to 60ms. The ability to receive data is signaled by CTS0 and CTS1. It is therefore recommended to enable RTS/CTS flow control, not only in CYCLIC SLEEP mode, but also in NON-CYCLIC SLEEP mode.

## 3.6 Summary of State Transitions (except SLEEP Mode)

The table shows how to proceed from one mode to another (grey column = present mode, white columns = intended modes)

**Table 11:** State transitions of BGS2-E/BGS2-W (except SLEEP mode)

Further mode →→ Present mode	Power Down	Normal mode	Alarm mode
Power Down mode	---	ON >10ms at VDDL P level	Wake-up from Power Down mode (if activated with AT+CALA)
Normal mode	AT^SMSO	EMERG_RST > 10ms	AT+CALA followed by AT^SMSO. BGS2-E/ BGS2-W enters Alarm mode when specified time is reached.
Alarm mode	AT^SMSO	AT+CFUN=x,1 or ON >10ms at VDDL P level	---

### 3.7 RTC Backup

The internal Real Time Clock of BGS2-E/BGS2-W is supplied from a separate voltage regulator in the power supply component which is also active when BGS2-E/BGS2-W is in Power Down mode and BATT+ is available. An alarm function is provided that allows to wake up BGS2-E/BGS2-W without logging on to the GSM network.

In addition, you can use the VDDLp pad to backup the RTC from an external capacitor. The capacitor is charged from the internal LDO of BGS2-E/BGS2-W. If the voltage supply at BATT+ is disconnected the RTC can be powered by the capacitor. The size of the capacitor determines the duration of buffering when no voltage is applied to BGS2-E/BGS2-W, i.e. the greater the capacitor the longer BGS2-E/BGS2-W will save the date and time. The RTC can also be supplied from an external battery (rechargeable or non-chargeable). In this case the electrical specification of the VDDLp pad (see [Section 5.4](#)) has to be taken in to account.

Figure 12 shows an RTC backup configuration.

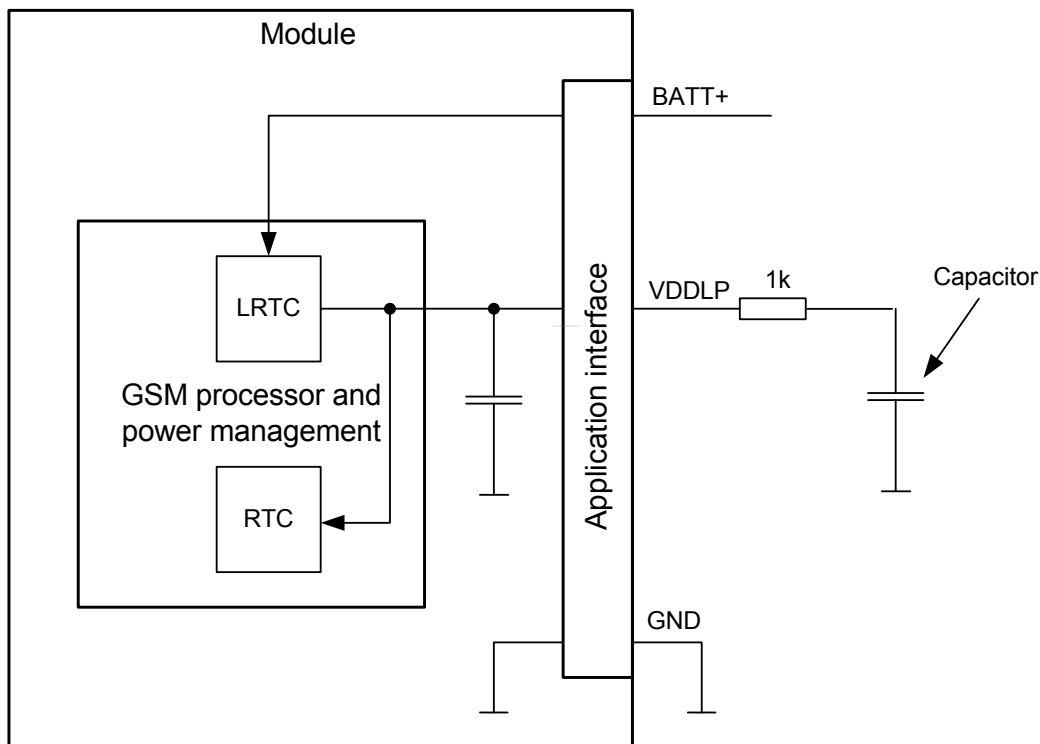

Figure 12: RTC supply variants

### 3.8 SIM/USIM Interface

The baseband processor has an integrated SIM/USIM card interface compatible with the ISO/IEC 7816 IC Card standard. This is wired to the host interface in order to be connected to an external SIM card holder. Five pads are reserved for the SIM interface. BGS2-E/BGS2-W supports and automatically detects 3.0V as well as 1.8V SIM cards.

The CCIN pad serves to detect whether a tray is present in the card holder. Using the CCIN pad is mandatory for compliance with the 3GPP TS 11.11 (Rel.99) recommendation if the mechanical design of the host application allows the user to remove the SIM card during operation.

**Table 12:** Signals of the SIM interface (SMT application interface)

Signal	Description
CCCLK	Chipcard clock, various clock rates can be set in the baseband processor.
CCVCC	SIM supply voltage from PSU-ASIC
CCIO	Serial data line, input and output.
CCRST	Chipcard reset, provided by baseband processor
CCIN	Input on the baseband processor for detecting a SIM card tray in the holder. The default level of CCIN is low (internal pull down resistor, no card inserted). It will change to high level when the card is inserted. To take advantage of this feature, an appropriate contact is required on the cardholder. Ensure that the cardholder on your application platform is wired to output a high signal when the SIM card is present. The CCIN pad is mandatory for applications that allow the user to remove the SIM card during operation. The CCIN pad is solely intended for use with a SIM card. It must not be used for any other purposes. Failure to comply with this requirement may invalidate the type approval of BGS2-E/BGS2-W.

The figure below shows a circuit to connect an external SIM card holder.

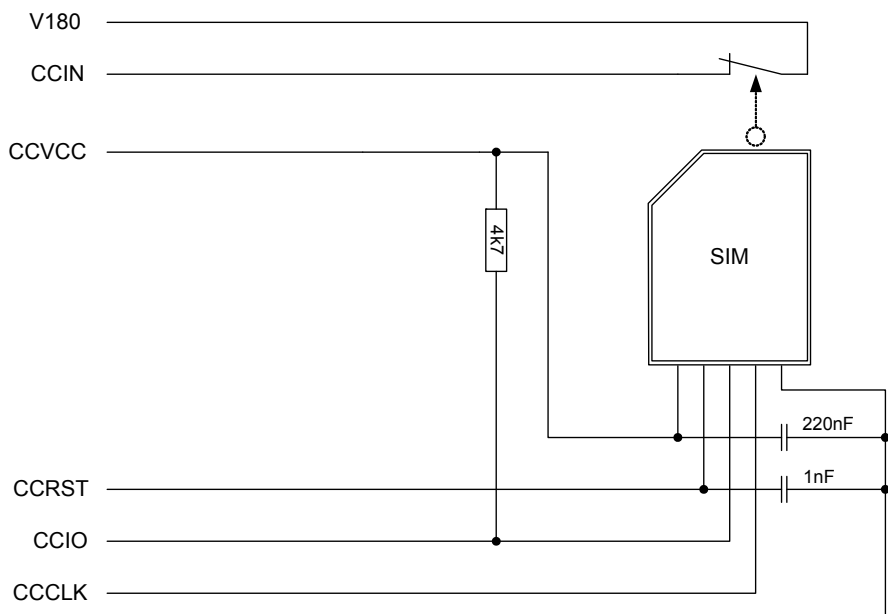

**Figure 13:** External SIM card holder circuit

It is recommended that the total cable length between SMT application interface pads on BGS2-E/BGS2-W and the connector of the external SIM card holder must not exceed 100mm in order to meet the specifications of 3GPP TS 51.010-1 and to satisfy the requirements of EMC compliance.

To avoid possible cross-talk from the CCCLK signal to the CCIO signal be careful that both lines are not placed closely next to each other. A useful approach would be to use a separate SIM card ground connection to shield the CCIO line from the CCCLK line. A GND line may be employed for such a case.

*Notes: No guarantee can be given, nor any liability accepted, if loss of data is encountered after removing the SIM card during operation.*

*Also, no guarantee can be given for properly initialising any SIM card that the user inserts after having removed a SIM card during operation. In this case, the application must restart BGS2-E/BGS2-W.*

*If using a SIM card holder without detecting contact please be sure to switch off the module before removing the SIM Card or inserting a new one.*

### 3.9 Serial Interface ASC0

BGS2-E/BGS2-W offers an 8-wire unbalanced, asynchronous modem interface ASC0 conforming to ITU-T V.24 protocol DCE signalling. The electrical characteristics do not comply with ITU-T V.28. The voltage level of the ASC0 interface can be configured to either 1.8V or 2.85V:

- If the VDIG signal (i.e., application interface pad 10) is connected to the V180 line (i.e., application interface pad 35) the ASC0 interface starts up with a 1.8V signal level.
- If the VDIG signal (i.e., application interface pad 10) is connected to the V285 line (i.e., application interface pad 22), the ASC0 interface runs with a 2.85V signal level.

The voltage level configuration of the ASC0 interface also has an impact on the I<sup>2</sup>C interface. The I<sup>2</sup>C interface is also in the power supply domain configured by the VDIG signal (see [Section 3.13](#)).

For electrical characteristics of the interface signals please refer to [Section 5.4](#).

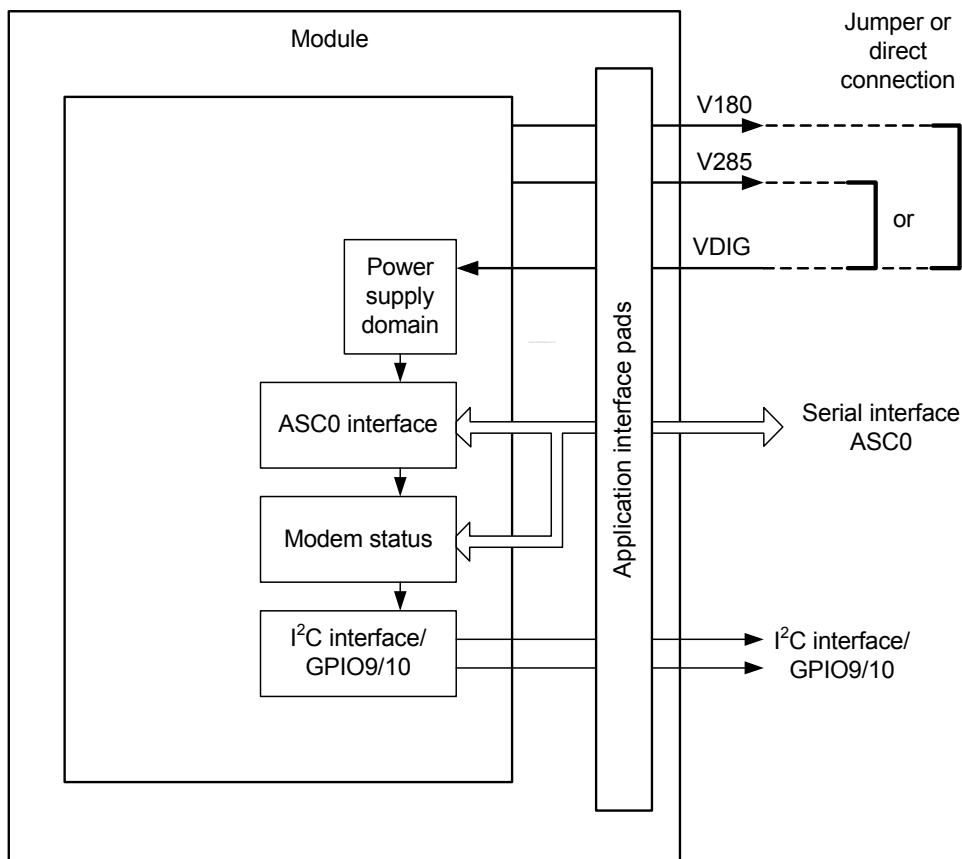

**Figure 14:** VDIG controlled power supply domain

BGS2-E/BGS2-W is designed for use as a DCE. Based on the conventions for DCE-DTE connections it communicates with the customer application (DTE) using the following signals:

- Port TXD @ application sends data to the module's TXD0 signal line
- Port RXD @ application receives data from the module's RXD0 signal line

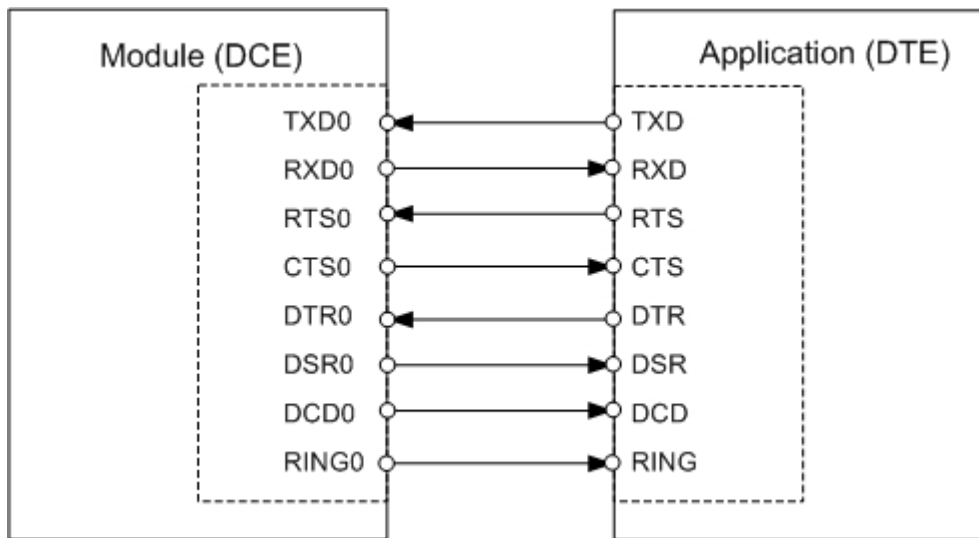

Figure 15: Serial interface ASC0

Features:

- Includes the data lines TXD0 and RXD0, the status lines RTS0 and CTS0 and, in addition, the modem control lines DTR0, DSR0, DCD0 and RING0.
- ASC0 is primarily designed for controlling voice calls, transferring CSD, fax and GPRS data and for controlling the GSM module with AT commands.
- The DTR0 signal will only be polled once per second from the internal firmware of BGS2-E/BGS2-W.
- The RING0 signal serves to indicate incoming calls and other types of URCs (Unsolicited Result Code). It can also be used to send pulses to the host application, for example to wake up the application from power saving state. See [1] for details on how to configure the RING0 line by AT^SCFG.
- Configured for 8 data bits, no parity and 1 stop bit.
- ASC0 can be operated at fixed bit rates from 1,200 bps to 230,400 bps.
- Autobauding supports bit rates from 1,200 bps to 230,400 bps.
- Supports RTS0/CTS0 hardware flow control and XON/XOFF software flow control.

Table 13: DCE-DTE wiring of ASC0

V.24 circuit	DCE		DTE	
	Pad function	Signal direction	Pad function	Signal direction
103	TXD0	Input	TXD	Output
104	RXD0	Output	RXD	Input
105	RTS0	Input	RTS	Output
106	CTS0	Output	CTS	Input
108/2	DTR0	Input	DTR	Output
107	DSR0	Output	DSR	Input
109	DCD0	Output	DCD	Input
125	RING0	Output	RING	Input



The following figure shows the startup behavior of the asynchronous serial interface ASC0.

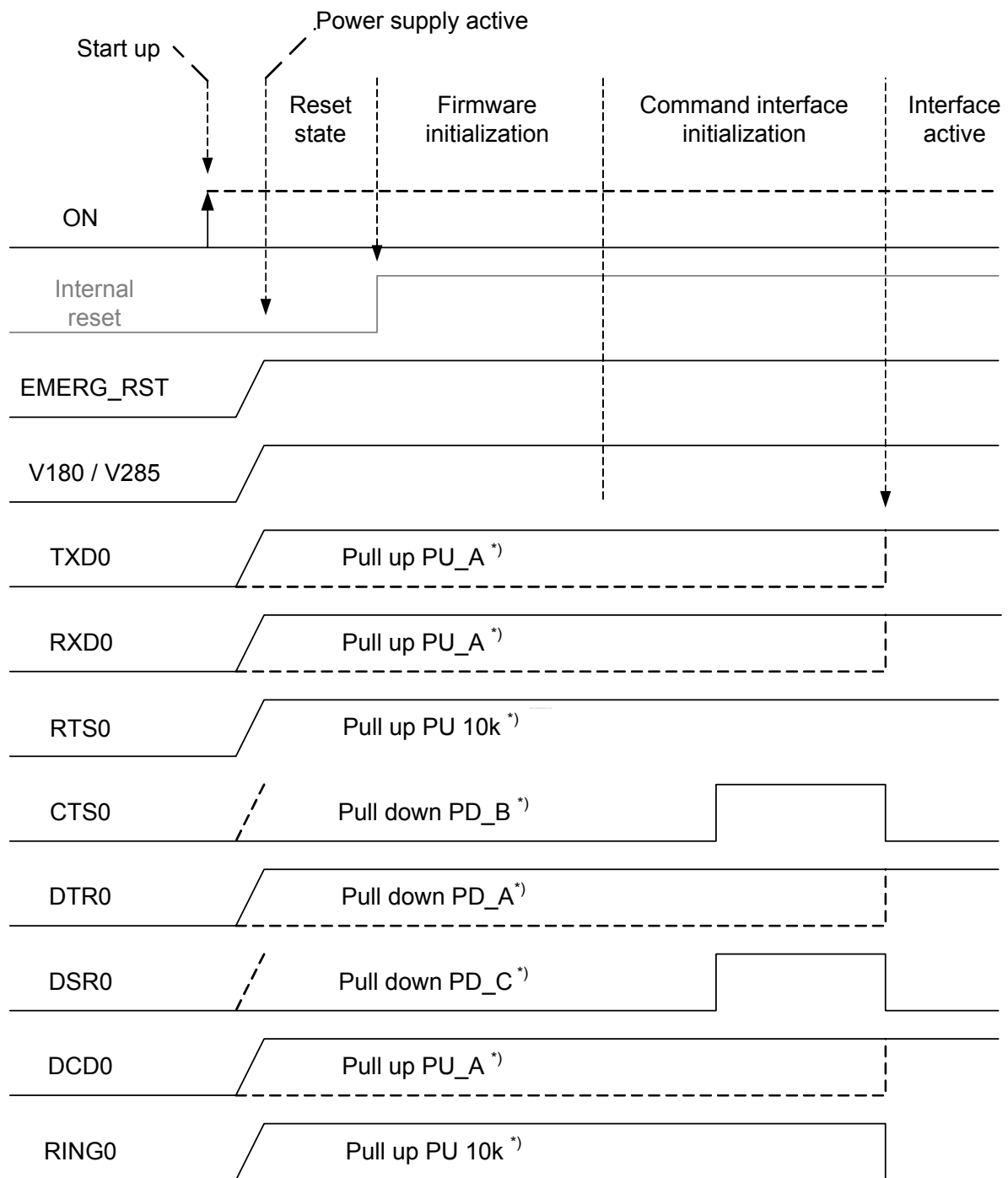

\*) For pull-up and pull-down values see [Table 8](#).

**Figure 16:** ASC0 startup behavior

Please note that no data must be sent over the ASC0 interface before the interface is active and ready to receive data (see [Section 3.3.1.1](#)).

### 3.10 Serial Interface ASC1

BGS2-E/BGS2-W offers a 4-wire unbalanced, asynchronous modem interface ASC1 conforming to ITU-T V.24 protocol DCE signalling. The electrical characteristics do not comply with ITU-T V.28. The electrical level of the ASC1 interface is set to 1.8V. For electrical characteristics please refer to [Table 23](#).

BGS2-E/BGS2-W is designed for use as a DCE. Based on the conventions for DCE-DTE connections it communicates with the customer application (DTE) using the following signals:

- Port TXD @ application sends data to module's TXD1 signal line
- Port RXD @ application receives data from the module's RXD1 signal line

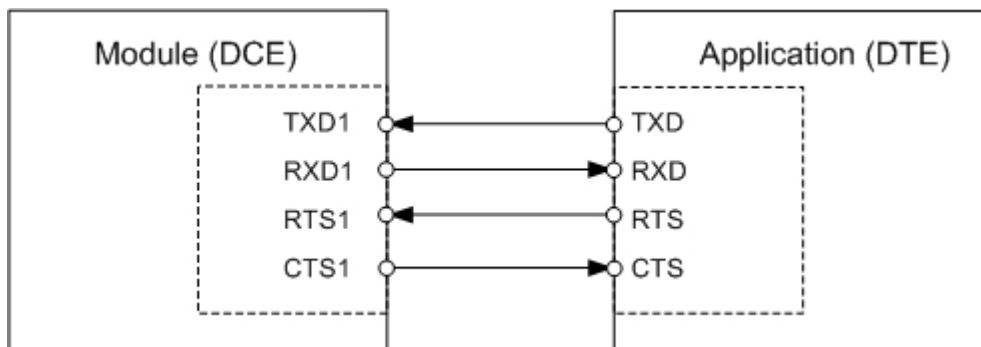

Figure 17: Serial interface ASC1

#### Features

- Includes only the data lines TXD1 and RXD1 plus RTS1 and CTS1 for hardware handshake.
- On ASC1 no RING line is available. The indication of URCs on the second interface depends on the settings made with the AT^SCFG command. For details refer to [\[1\]](#).
- Configured for 8 data bits, no parity and 1 or 2 stop bits.
- ASC1 can be operated at fixed bit rates from 1,200 bps to 230,400 bps. Autobauding is not supported on ASC1.
- Supports RTS1/CTS1 hardware flow control and XON/XOFF software flow control.

Table 14: DCE-DTE wiring of ASC1

V.24 circuit	DCE		DTE	
	Line function	Signal direction	Line function	Signal direction
103	TXD1	Input	TXD	Output
104	RXD1	Output	RXD	Input
105	RTS1	Input	RTS	Output
106	CTS1	Output	CTS	Input

The following figure shows the startup behavior of the asynchronous serial interface ASC1.

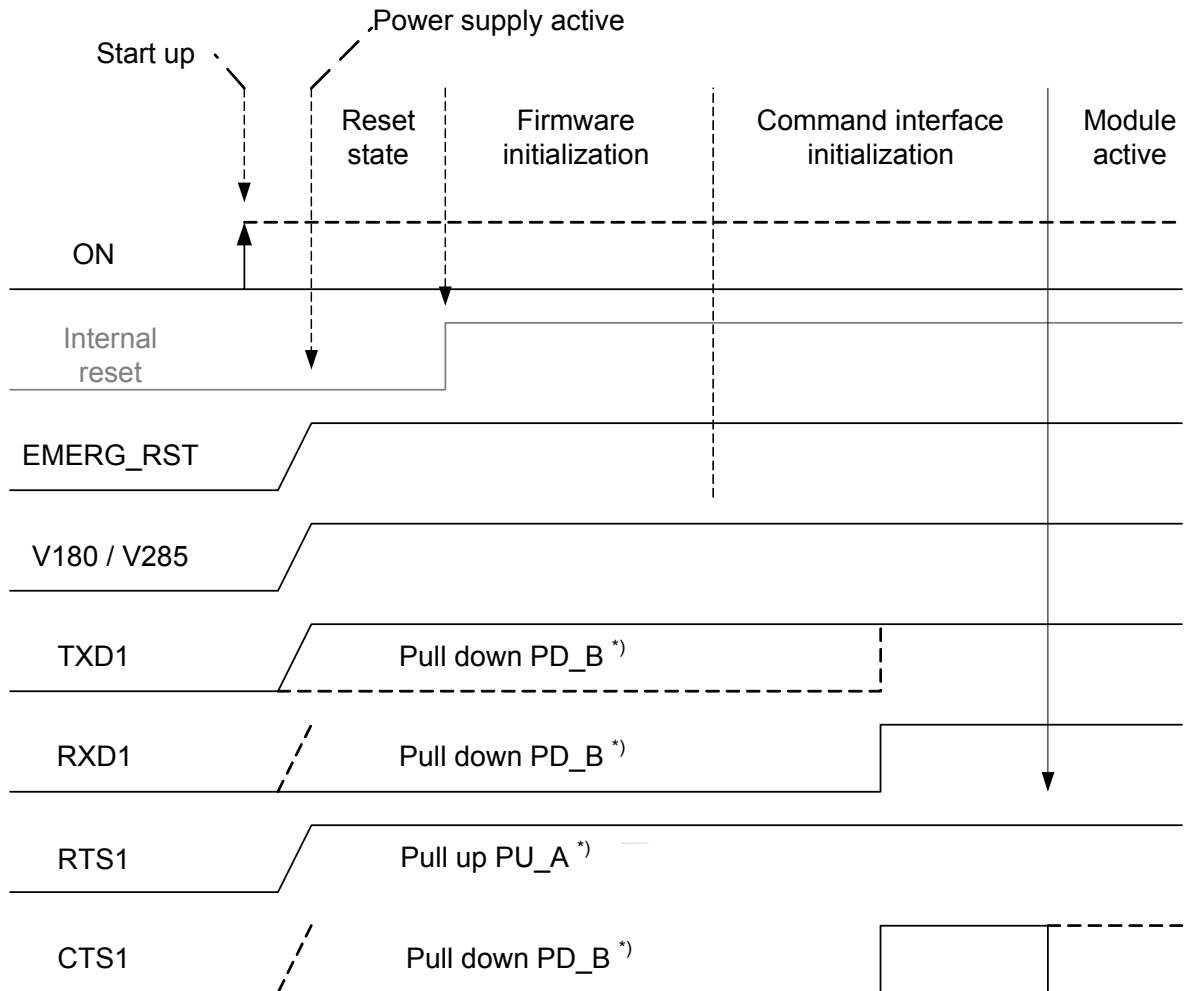

\*) For pull-up and pull-down values see [Table 8](#).

**Figure 18:** ASC1 startup behavior

## 3.11 Analog Audio Interface

BGS2-E/BGS2-W has an analog audio interface with a balanced analog microphone input and a balanced analog earpiece output. A supply voltage and an analog ground connection are provided at dedicated pads.

BGS2-E/BGS2-W offers six audio modes which can be selected with the AT^SNFS command. The electrical characteristics of the voiceband part vary with the audio mode. For example, sending and receiving amplification, sidetone paths, noise suppression etc. depend on the selected mode and can be altered with AT commands (except for mode 1).

Please refer to [Section 5.6](#) for specifications of the audio interface and an overview of the audio parameters. Detailed instructions on using AT commands are presented in [1]. [Table 27](#) summarizes the characteristics of the various audio modes and shows what parameters are supported in each mode.

When shipped from factory, all audio parameters of BGS2-E/BGS2-W are set to audio mode 1. This is the default configuration optimised for the Votronic HH-SI-30.3/V1.1/0 handset and used for type approving the Cinterion Wireless Modules reference configuration. Audio mode 1 has fix parameters which cannot be modified. To adjust the settings of the Votronic handset simply change to another audio mode.

In transmit direction, all audio modes contain internal scaling factors (digital amplification) that are not accessible.

### 3.11.1 Microphone Inputs and Supply

The differential microphone inputs MICP and MICN present an impedance of 50kOhm and must be decoupled by capacitors (typical 100nF). A regulated power supply for electret microphones is available at VMIC. The voltage at VMIC is rated at 2.2V and available while audio is active (e.g., during a call). It can also be controlled by AT^SNFM. It is recommended to use an additional RC-filter if a high microphone gain is necessary. It is also recommended to use the AGND line for grounding the microphone circuit. AGND provides for the same module ground potential the analog circuits of the module refer to. AGND must not be connected to the system GND anywhere. Otherwise, high GSM burst peak currents will flow across the AGND line causing GSM humming in the uplink audio signal.

The following figures show possible microphone and line connections.

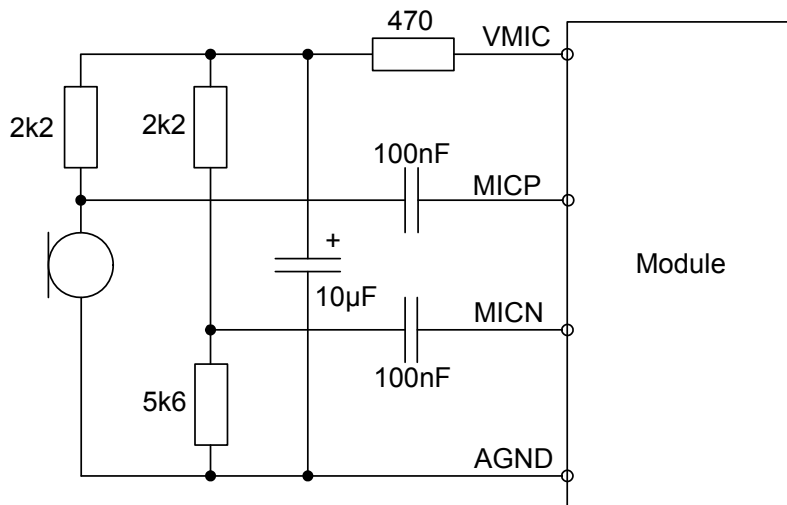

Figure 19: Single ended microphone connection

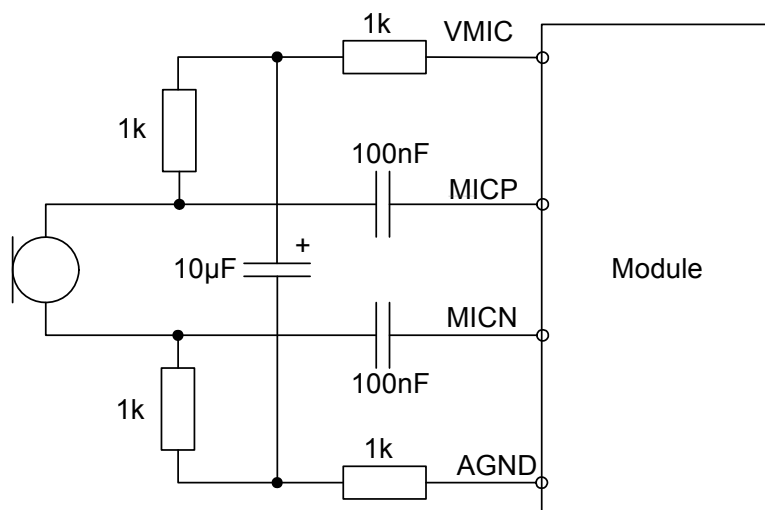

Figure 20: Differential Microphone connection

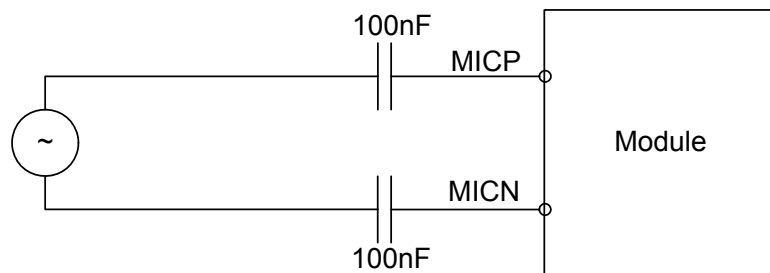

Figure 21: Line Input

### 3.11.2 Loudspeaker Output

BGS2-E/BGS2-W provides a differential loudspeaker output EPP/EPN. The output is able to deliver a voltage of 3.2Vpp at a load resistance of 16Ohm. If it is used as line output (see [Figure 23](#)), the application should provide a capacitor decoupled differential input to eliminate GSM humming. A first order low pass filter above 4kHz may be useful to improve the out-of-band signal attenuation. A single ended connection to a speaker or a line input should not be realized.

The following figures show the typical output configurations.

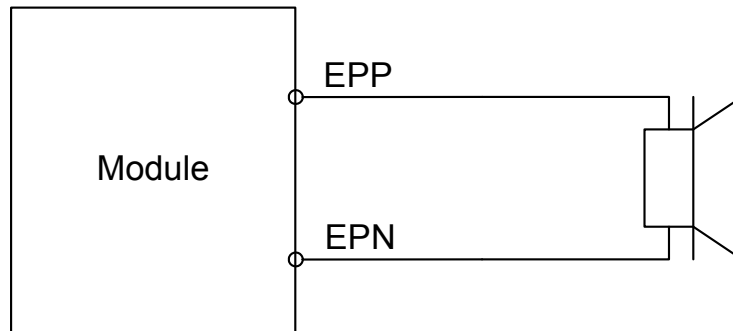

Figure 22: Differential loudspeaker connection

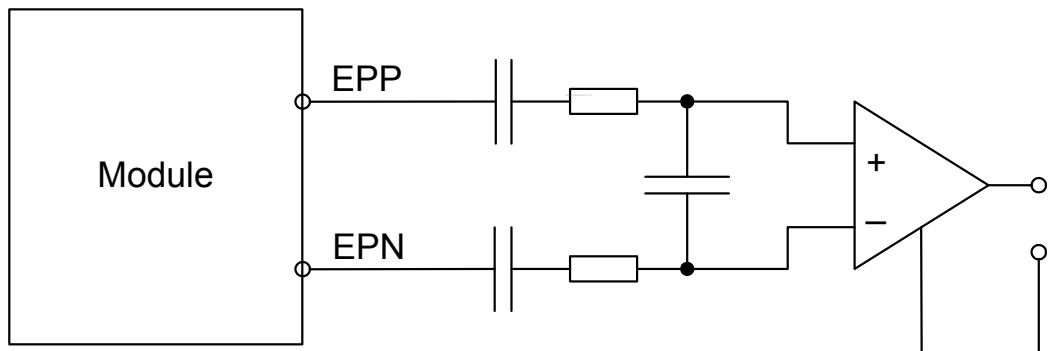

Figure 23: Line output connection

## 3.12 GPIO Interface

BGS2-E/BGS2-W offers a GPIO interface with 10 GPIO lines. Some GPIO lines are shared with other interfaces, such as I<sup>2</sup>C interface (see [Section 3.13](#)), Status LED (see [Section 3.15](#)) and the PWM functionality (see [Section 3.14](#)). All functions are controlled by dedicated AT commands.

The following table shows the configuration variants of the GPIO pads. All variants are mutually exclusive, i.e. a pad configured as GPIO is locked for alternative use.

**Table 15:** GPIO assignment

GPIO	I2C	PWM	Status LED	Voltage domain
GPIO1				V180
GPIO2				V180
GPIO3				V180
GPIO4				V180
GPIO5			Status LED	V180
GPIO6		PWM2		V180
GPIO7		PWM1		V180
GPIO8				V180
GPIO9	I2CDAT			VDIG
GPIO10	I2CCLK			VDIG

Each GPIO line can be configured for use as input or output. The GPIO related AT commands are the following: AT<sup>^</sup>SPIO, AT<sup>^</sup>SCPIN, AT<sup>^</sup>SGIO, AT<sup>^</sup>SSIO. A detailed description can be found in [\[1\]](#).

When the BGS2-E/BGS2-W starts up, all GPIO lines are set to high-impedance state after initializing, as described in [Section 3.3.3](#). Therefore, it is recommended to connect external pull-up or pull-down resistors to all GPIO lines you want to use as output. This is necessary to keep these lines from floating or driving any external devices before all settings are done by AT command (at least AT<sup>^</sup>SPIO, AT<sup>^</sup>SCPIN), and after closing the GPIOs again.

The power supply domain voltage level for GPIO1 to GPIO8 is 1.8V. GPIO9 and GPIO10 are in the VDIG power supply domain which can be configured to either a 1.8V or a 2.85V voltage level (for details see [Section 3.9](#); [Figure 14](#)). I2CCLK (GPIO10) has an internal 5kOhm pull-up resistor, I2CDAT (GPIO9) requires an external pull-up resistor.

The following figure shows the startup behavior of the GPIO interface. With an active state of the ASC0 interface (i.e. RING0, CTS0 or CTS1 are at low level) the initialization of the GPIO interface lines is also finished.

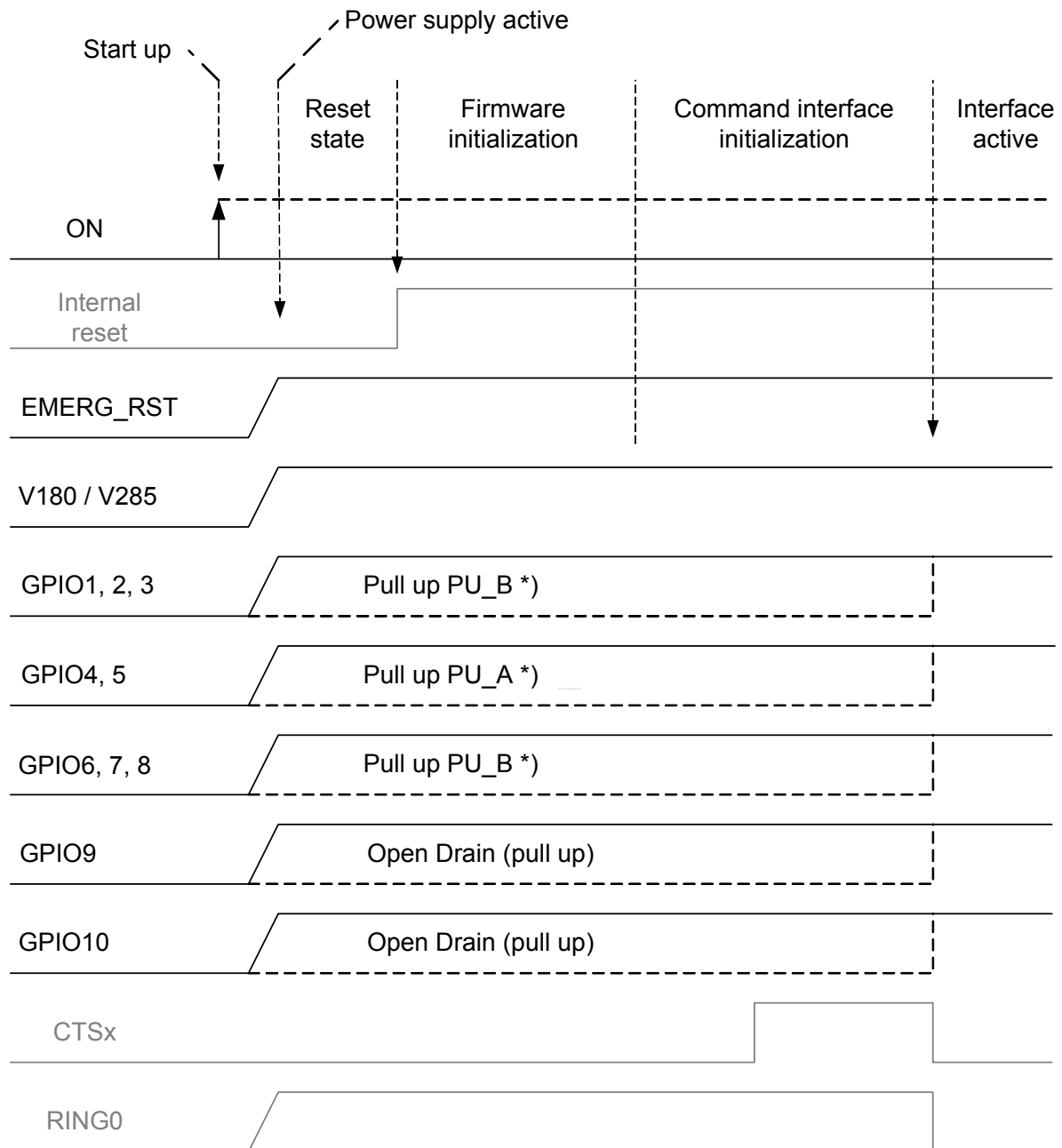

\*) For pull-up values see [Table 8](#).

**Figure 24:** GPIO startup behavior



### 3.13 I<sup>2</sup>C Interface

The signal lines of the I<sup>2</sup>C interface are shared with the GPIO9 and GPIO10 signal pads and are activated by means of AT command. For details see [1]: AT<sup>^</sup>SSPI.

The voltage level configuration for the ASC0 interface has an impact on the I<sup>2</sup>C interface since the I<sup>2</sup>C interface is in the same VDIG controlled power supply domain. If the ASC0 voltage level is set to 1.8V, the I<sup>2</sup>C interface pads have the same voltage level (see Figure 14).

I<sup>2</sup>C is a serial, 8-bit oriented data transfer bus for bit rates up to 400kbps in Fast mode. It consists of two lines, the serial data line I2CDAT (GPIO9) and the serial clock line I2CCLK (GPIO10). The module acts as a single master device, e.g. the clock I2CCLK is driven by the module. I2CDAT is a bi-directional line. Each device connected to the bus is software addressable by a unique 7-bit address, and simple master/slave relationships exist at all times. The module operates as master-transmitter or as master-receiver. The customer application transmits or receives data only on request of the module.

The I<sup>2</sup>C interface can be powered from an external supply or via the V180/V285 line of BGS2-E/BGS2-W. If connected to the V180/V285 line, the I<sup>2</sup>C interface will be properly shut down when the module enters the Power Down mode. If you prefer to connect the I<sup>2</sup>C interface to an external power supply, take care that VCC of the application is in the range of V180/V285 and that the interface is shut down when the EMERG\_RST signal goes low.

In the application I2CDAT and I2CCLK lines need to be connected to a positive supply voltage via a pull-up resistor. For electrical characteristics please refer to Table 23.

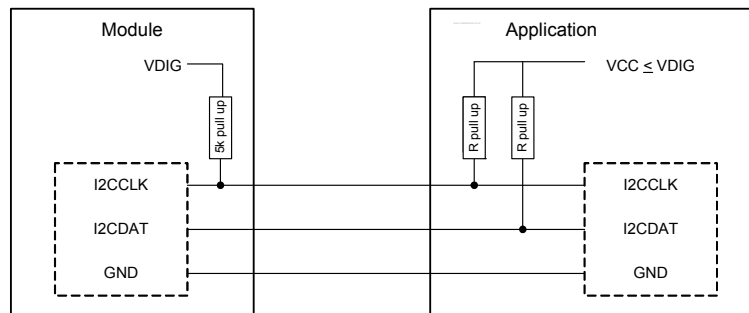

Figure 25: I<sup>2</sup>C interface connected to VCC of application

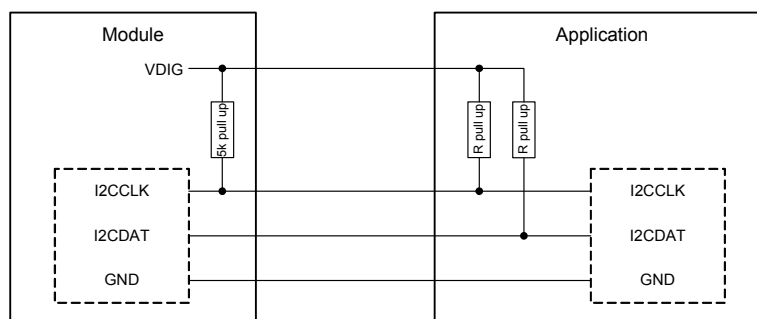

Figure 26: I<sup>2</sup>C interface connected to V180 or V285

*Note: Good care should be taken when creating the PCB layout of the host application: The traces of I2CCLK and I2CDAT should be equal in length and as short as possible.*

The following figure shows the startup behavior of the I<sup>2</sup>C interface. With an active state of the ASC0 interface (i.e. RING0, CTS0 or CTS1 are at low level) the initialization of the I<sup>2</sup>C interface is also finished.

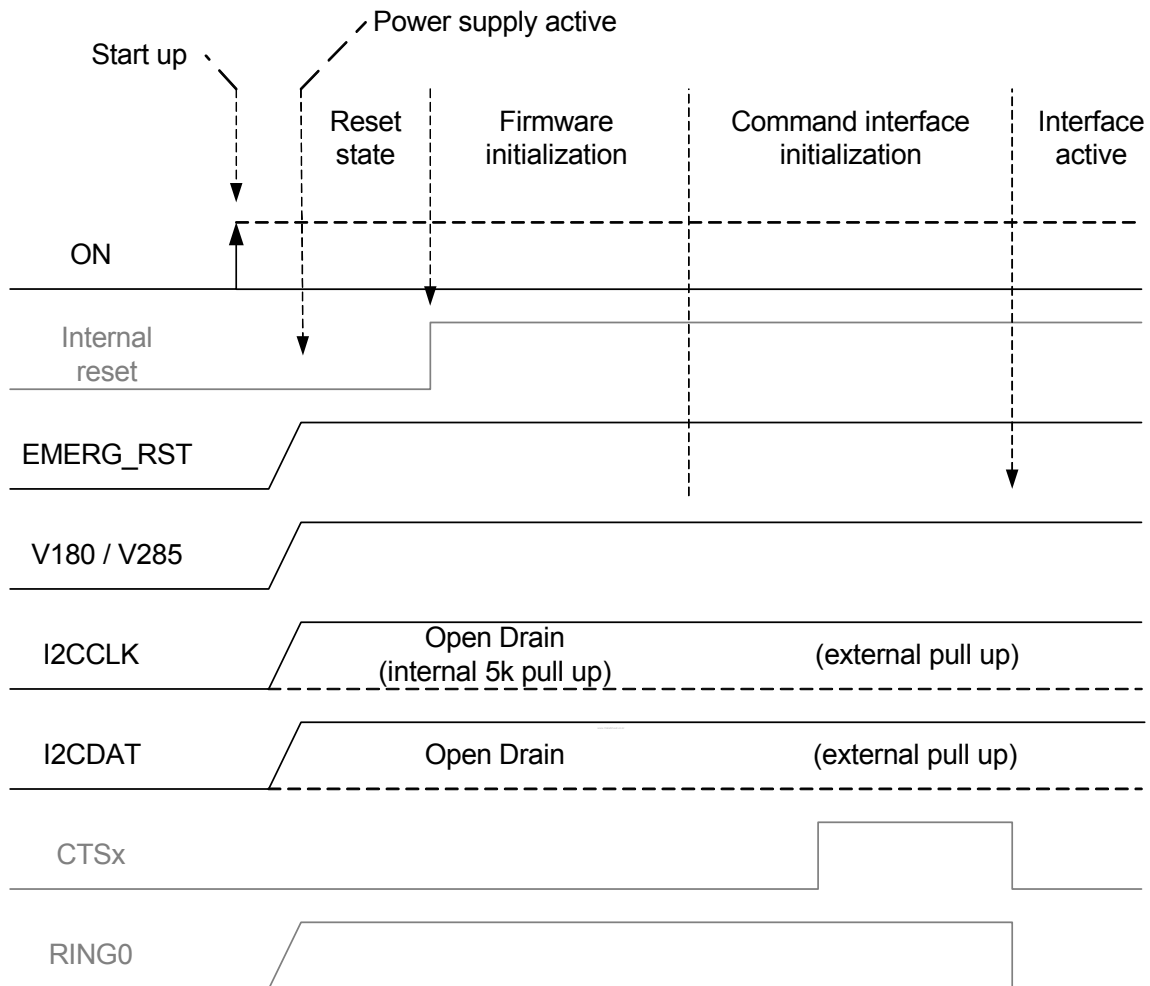

Figure 27: I<sup>2</sup>C startup behavior

### 3.14 PWM Interfaces

BGS2-E/BGS2-W offers two PWM (Pulse Width Modulation) interfaces, which can be used, for example, to connect buzzers. The PWM1 line is shared with GPIO7 and the PWM2 line is shared with GPIO6 (for GPIOs see [Section 3.12](#)). GPIO and PWM functionality are mutually exclusive.

The startup behavior of the lines is shown in [Figure 24](#).

To open and configure a PWM output use the AT<sup>^</sup>SWDAC command. For details refer to [\[1\]](#).

### 3.15 Status LED

The GPIO5 line at the SMT application interface can be configured to drive a status LED which indicates different operating modes of the module (for GPIOs see [Section 3.12](#)). GPIO and LED functionality are mutually exclusive.

To take advantage of this function connect an LED to the GPIO5/LED line as shown in [Figure 28](#). The LED can be enabled/disabled by AT command. For details refer to [\[1\]](#): AT<sup>^</sup>SSYNC.

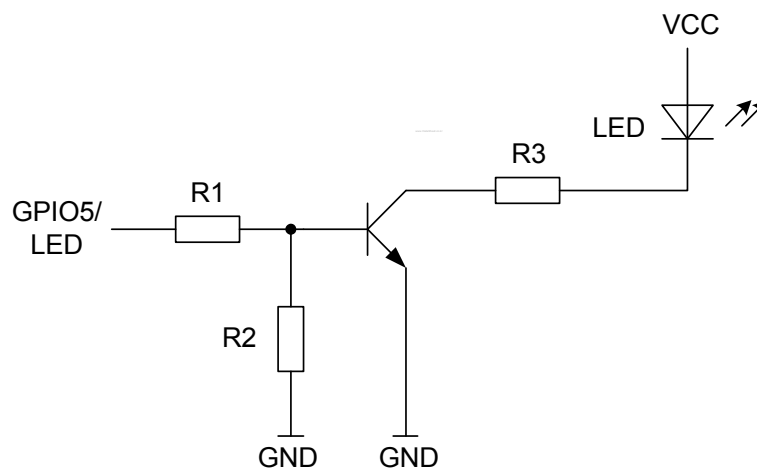

**Figure 28:** Status signalling with LED driver

### 3.16 Behavior of the RING0 Line (ASC0 Interface only)

The RING0 line is available on the first serial interface (ASC0). The signal serves to indicate incoming calls and other types of URCs (Unsolicited Result Code).

Although not mandatory for use in a host application, it is strongly suggested that you connect the RING0 line to an interrupt line of your application. In this case, the application can be designed to receive an interrupt when a falling edge on RING0 occurs. This solution is most effective, particularly, for waking up an application from power saving. Note that if the RING0 line is not wired, the application would be required to permanently poll the data and status lines of the serial interface at the expense of a higher current consumption. Therefore, utilizing the RING0 line provides an option to significantly reduce the overall current consumption of your application.

The behavior of the RING0 line varies with the type of event:

- When a voice call comes in the RING0 line goes low for 1s and high for another 4s. Every 5 seconds the ring string is generated and sent over the RXD0 line. If there is a call in progress and call waiting is activated for a connected handset or handsfree device, the RING0 line switches to ground in order to generate acoustic signals that indicate the waiting call.

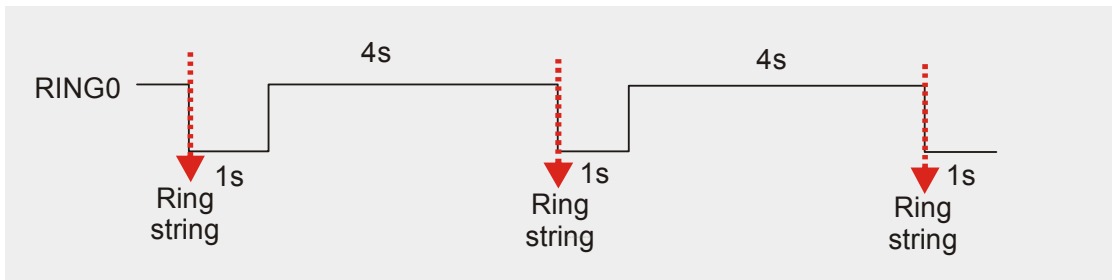

Figure 29: Incoming voice call

- Likewise, when a data or fax call is received, RING0 goes low. However, in contrast to voice calls, the line remains low. Every 5 seconds the ring string is generated and sent over the RXD0 line.

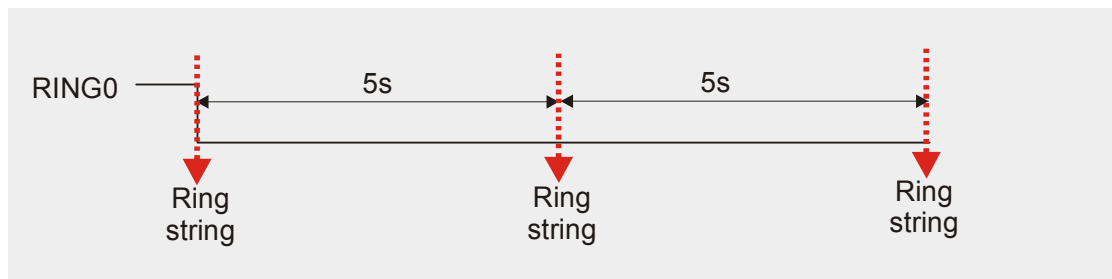

Figure 30: Incoming voice call

- All other types of Unsolicited Result Codes (URCs) also cause the RING0 line to go low, however for 1 second only.

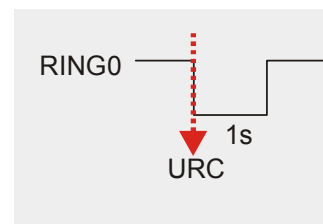

Figure 31: URC transmission

### 3.17 Power Indication Circuit

In Power Down mode the maximum voltage at any digital or analog interface line must not exceed +0.3V (see also [Section 5.1](#)). Exceeding this limit for any length of time might cause permanent damage to the module.

It is therefore recommended to implement a power indication signal that reports the module's power state and shows whether it is active or in Power Down mode. While the module is in Power Down mode all signals with a high level from an external application need to be set to low state or high impedance state. The sample power indication circuit illustrated in [Figure 32](#) denotes the module's active state with a low signal and the module's Power Down mode with a high signal or high impedance state.

The following [Table 16](#) lists two different configurations for the module's interfaces, depending on the power supply domain specified with VDIG. The cases differ in the power supply voltage level configured for the ASC0, ASC1, I<sup>2</sup>C and GPIO interface lines and the possibility of back powering through the used interface lines from an external application:

- If all interface lines operate within the V180 power supply domain (i.e., VDIG connected to V180), the V285 power supply voltage line is not prone to back powering. The power indication circuit is therefore controlled by the power supply voltage line V285.
- If the ASC0 and I<sup>2</sup>C interface lines operate within the V285 power supply domain (i.e., VDIG connected to V285), the V180 power supply voltage line is not prone to back powering. The power indication circuit is therefore controlled by the power supply voltage line V180.

**Table 16:** Power indication circuit

Interface	VDIG = V180	VDIG = V285
	Voltage level at interface	Voltage level at interface
ASC0 lines	1.8V	2.85V
ASC1 lines	1.8V	1.8V
I <sup>2</sup> C lines	1.8V	2.85V
GPIO lines	1.8V	1.8V
Voltage control for power indication circuit	V285 controlled	V180 controlled

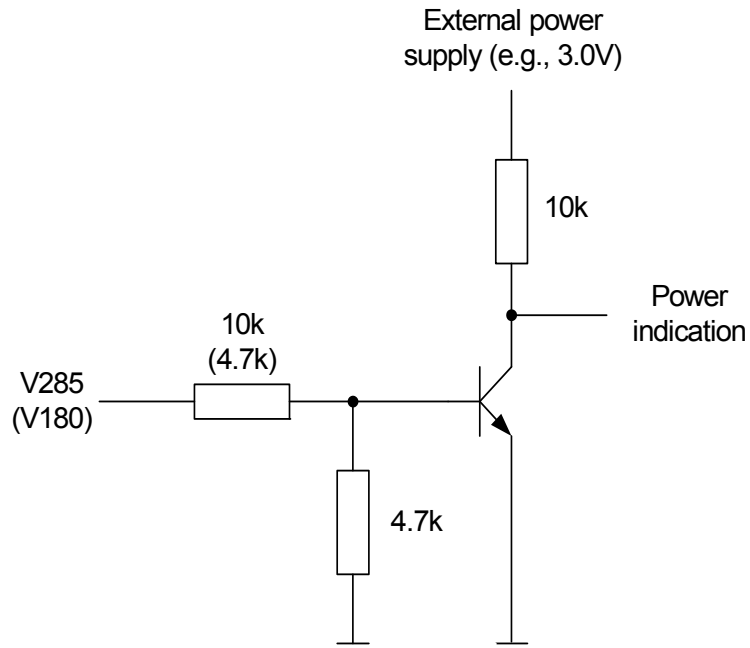

Figure 32: Power indication circuit

## 4 Antenna Interface

The RF interface has an impedance of 50Ω. BGS2-E/BGS2-W is capable of sustaining a total mismatch at the antenna lines without any damage, even when transmitting at maximum RF power.

The external antenna must be matched properly to achieve best performance regarding radiated power, modulation accuracy and harmonic suppression. Antenna matching networks are not included on the BGS2-E/BGS2-W module and should be placed in the host application if the antenna does not have an impedance of 50Ω.

Regarding the return loss BGS2-E/BGS2-W provides the following values in the active band:

**Table 17:** Return loss in the active band

State of module	Return loss of module	Recommended return loss of application
Receive	≥ 8dB	≥ 12dB
Transmit	not applicable	≥ 12dB

## 4.1 Antenna Installation

The antenna is connected by soldering the antenna pad (RF\_OUT, i.e., pad #59) and its neighboring ground pads (GND, i.e., pads #58 and #60) directly to the application's PCB. The antenna pad is the antenna reference point (ARP) for BGS2-E/BGS2-W. All RF data specified throughout this document is related to the ARP.

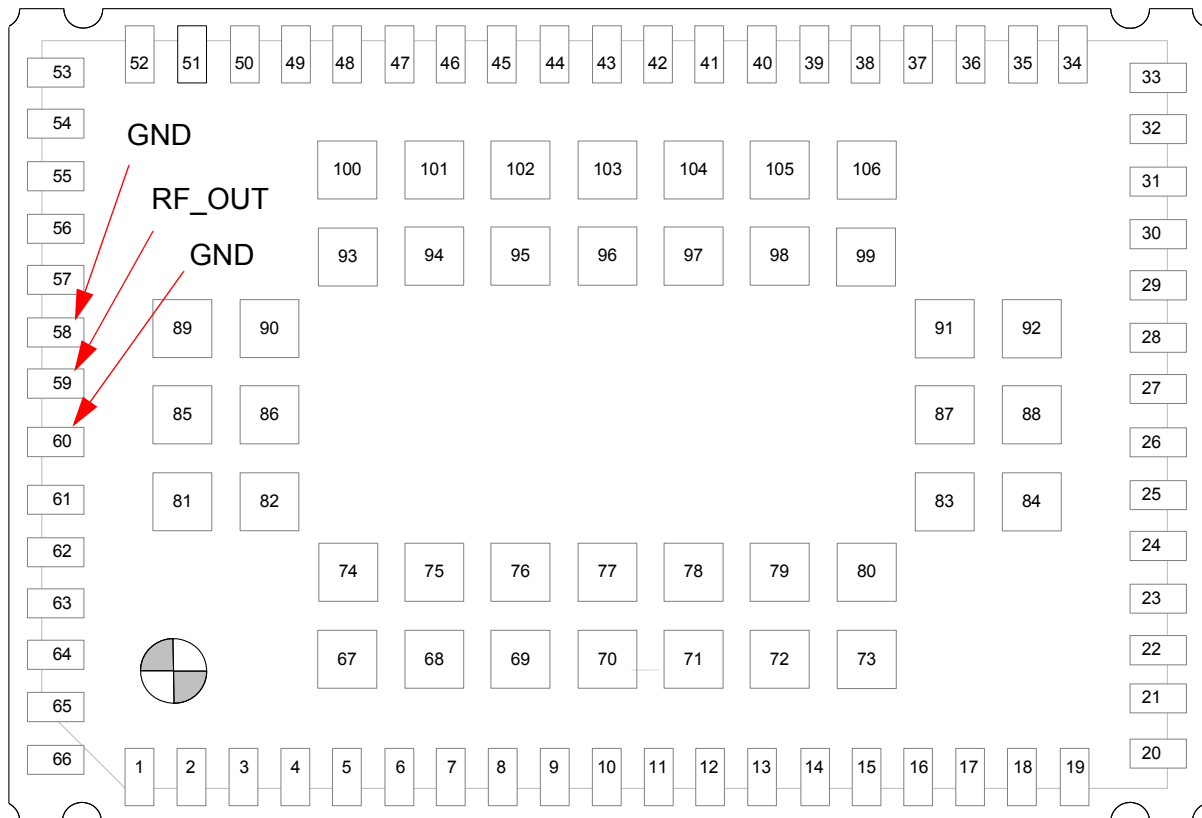

Figure 33: Antenna pads (bottom view)

The distance between the antenna RF\_OUT pad (#59) and its neighboring GND pads (#58, #60) has been optimized for best possible impedance. On the application PCB, special attention should be paid to these 3 pads, in order to prevent mismatch.

The wiring of the antenna connection line, starting from the antenna pad to the application antenna should result in a 50Ω line impedance. Line width and distance to the GND plane needs to be optimized with regard to the PCB's layer stack. Some examples are given in [Section 4.2](#).

To prevent receiver desensitization due to interferences generated by fast transients like high speed clocks on the application PCB, it is recommended to realize the antenna connection line using embedded Stripline rather than Micro-Stripline technology. Please see [Section 4.2.1](#) for an example.

For type approval purposes, the use of a 50Ω coaxial antenna connector (U.FL-R-SMT) might be necessary. In this case the U.FL-R-SMT connector should be placed as close as possible to BGS2-E/BGS2-W's antenna pad.



## 4.2 RF Line Routing Design

### 4.2.1 Line Arrangement Examples

Several dedicated tools are available to calculate line arrangements for specific applications and PCB materials - for example from <http://www.polarinstruments.com/> (commercial software) or from <http://web.awrcorp.com/Usa/Products/Optional-Products/TX-Line/> (free software).

#### 4.2.1.1 Embedded Stripline

This below figure shows a line arrangement example for embedded stripline with 65µm FR4 prepreg (type: 1080) and 710µm FR4 core (4-layer PCB).

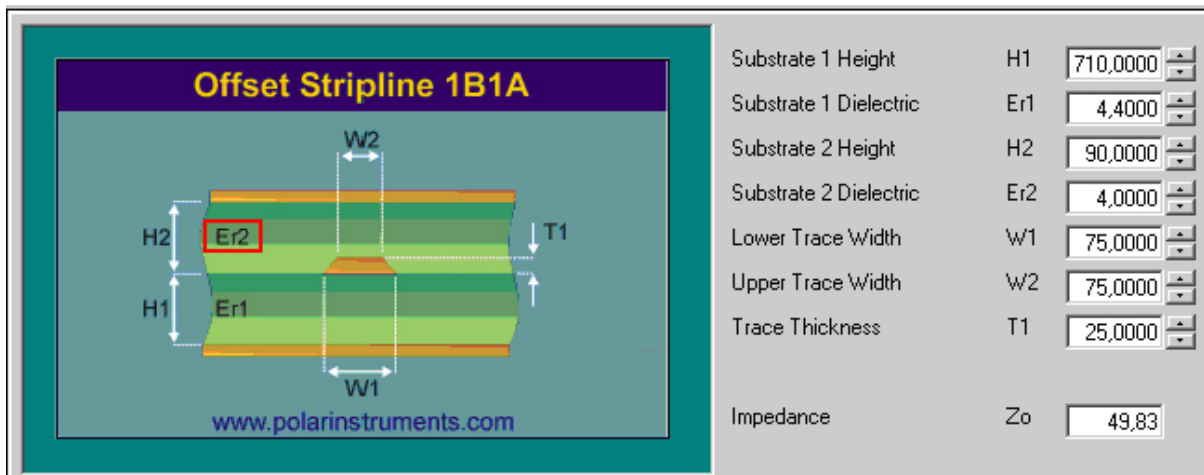

Figure 34: Embedded Stripline with 65µm prepreg (1080) and 710µm core

### 4.2.1.2 Micro-Stripline

This section gives two line arrangement examples for micro-stripline.

#### Micro-Stripline on 1.0mm Standard FR4 2-Layer PCB

The following two figures show examples with different values for D1 (ground strip separation).

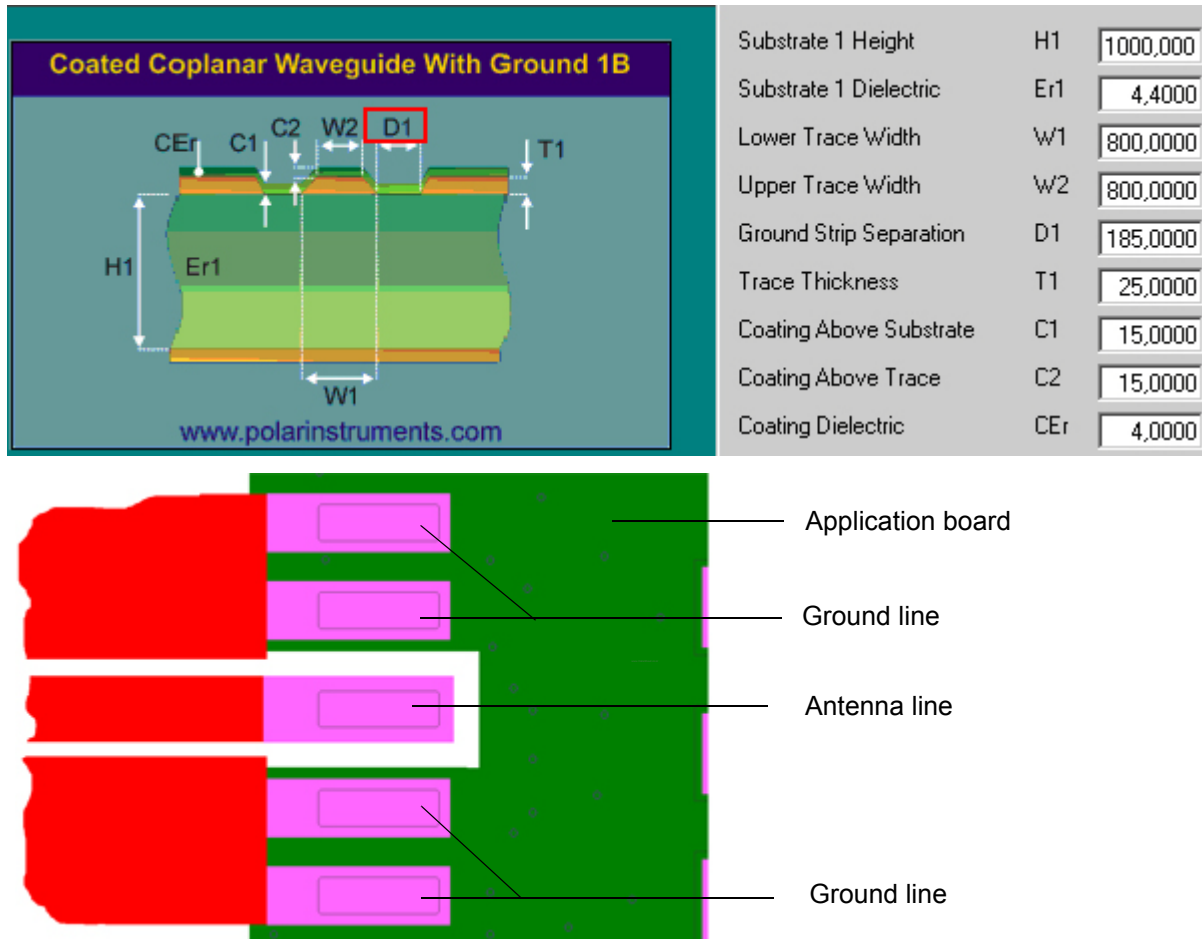

Figure 35: Micro-Stripline on 1.0mm standard FR4 2-layer PCB - example 1

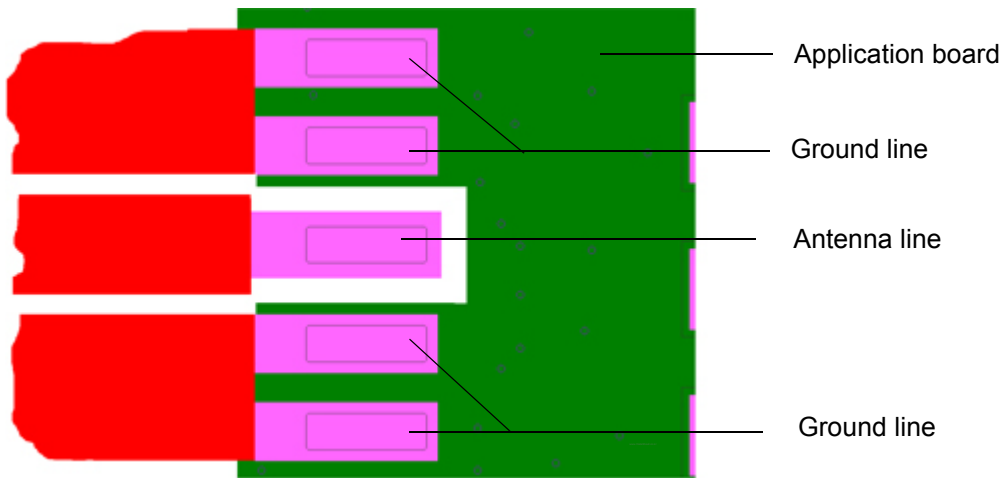
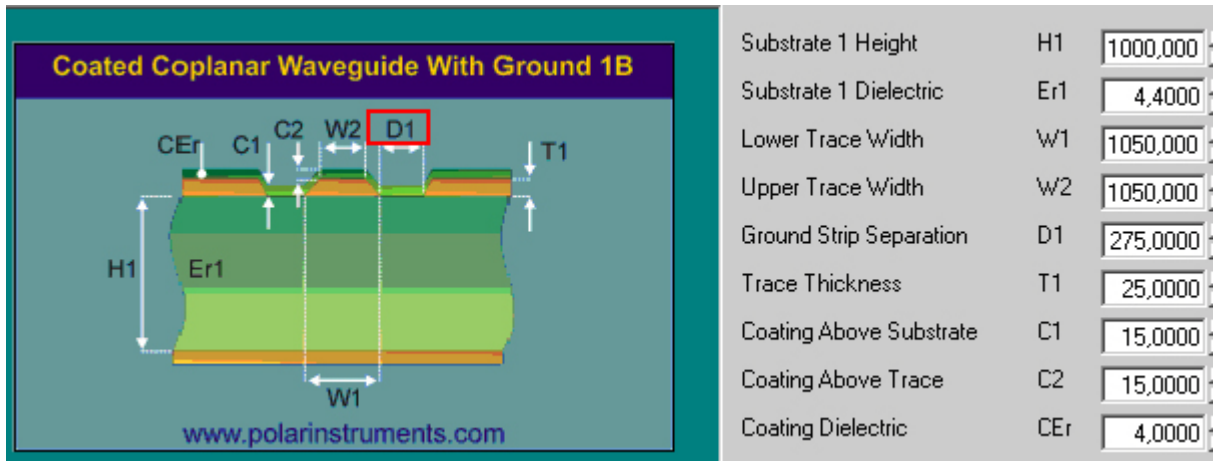
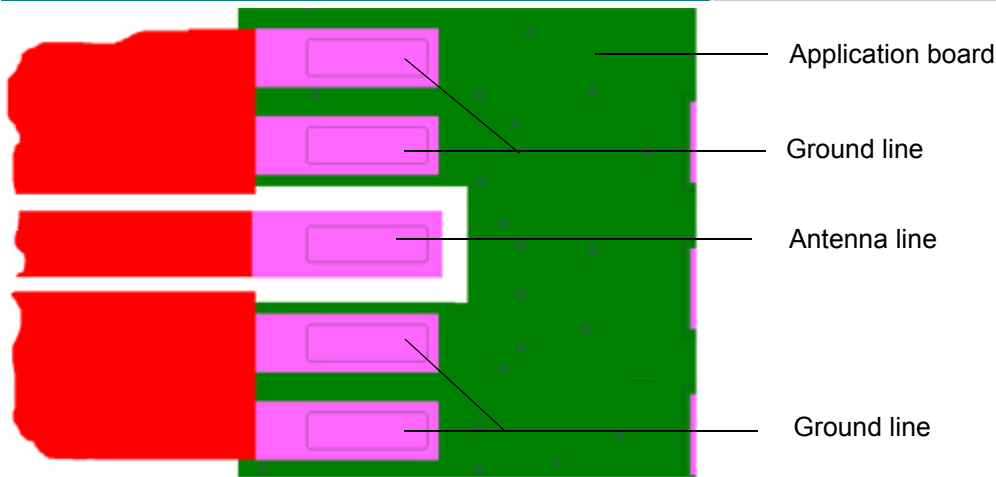
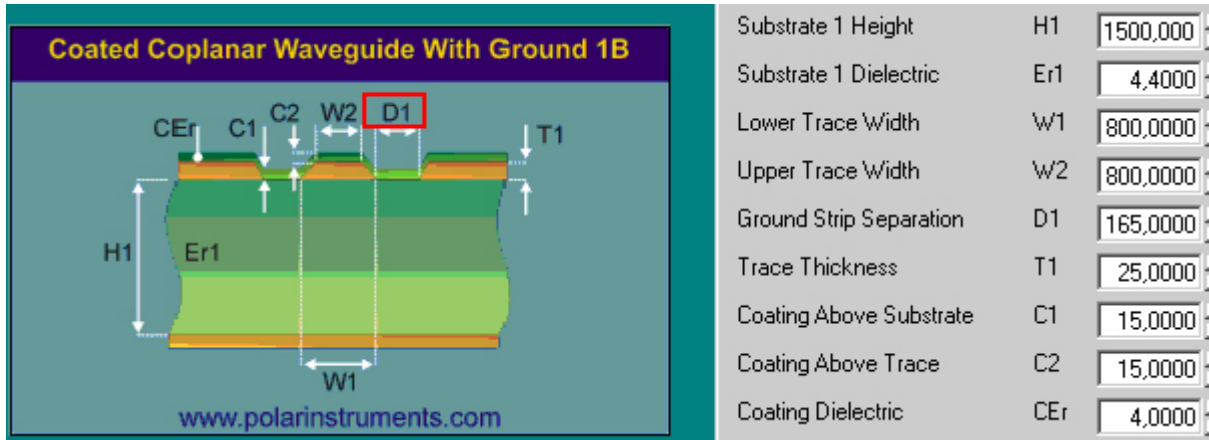

Figure 36: Micro-Stripline on 1.0mm Standard FR4 PCB - example 2

**Micro-Stripline on 1.5mm Standard FR4 2-Layer PCB**

The following two figures show examples with different values for D1 (ground strip separation).



**Figure 37:** Micro-Stripline on 1.5mm Standard FR4 PCB - example 1

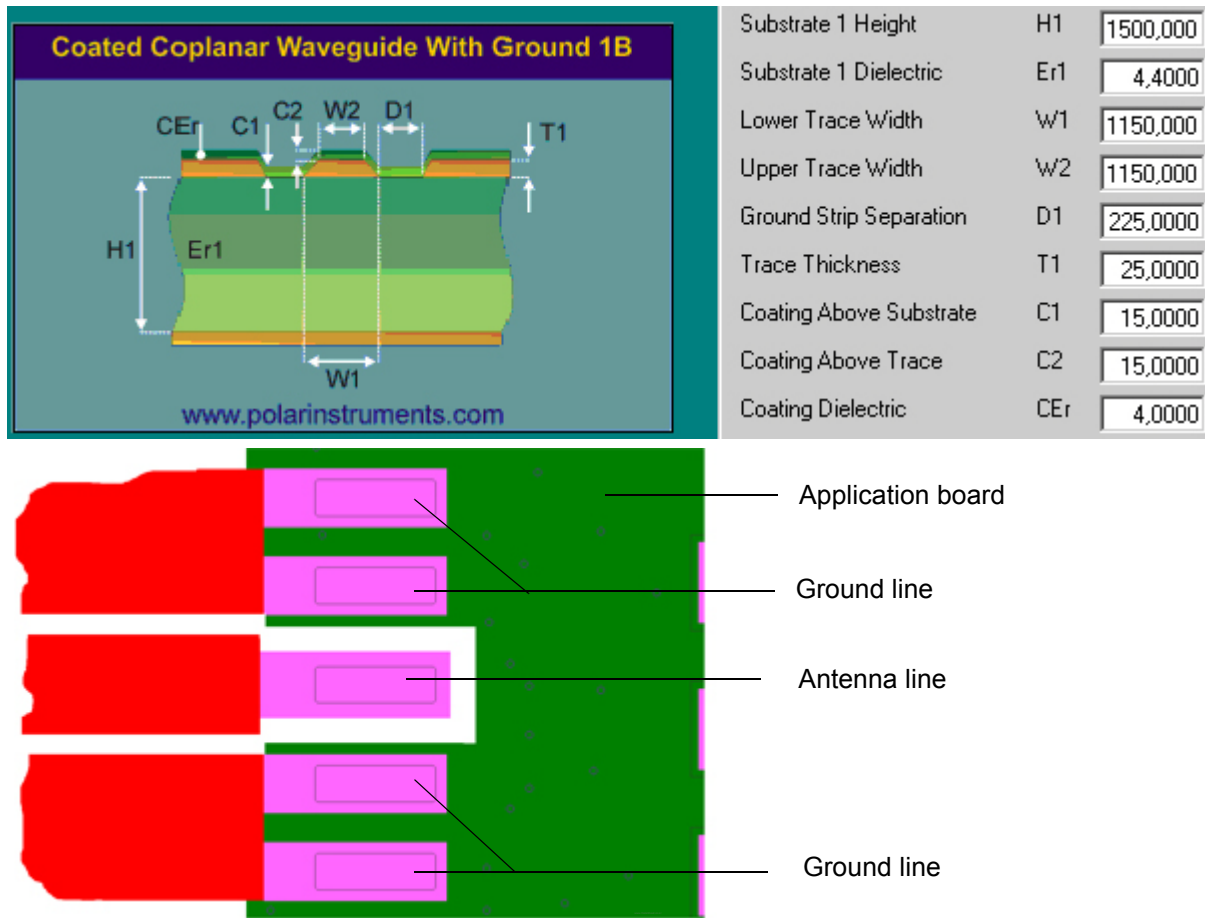

Figure 38: Micro-Stripline on 1.5mm Standard FR4 PCB - example 2

## 4.2.2 Routing Example

### 4.2.2.1 Interface to RF Connector

Figure 39 shows the connection of the module's antenna pad with an application PCB's coaxial antenna connector. Please note that the BGS2-E/BGS2-W bottom plane appears mirrored, since it is viewed from BGS2-E/BGS2-W top side. By definition the top of customer's board shall mate with the bottom of the BGS2-E/BGS2-W module.

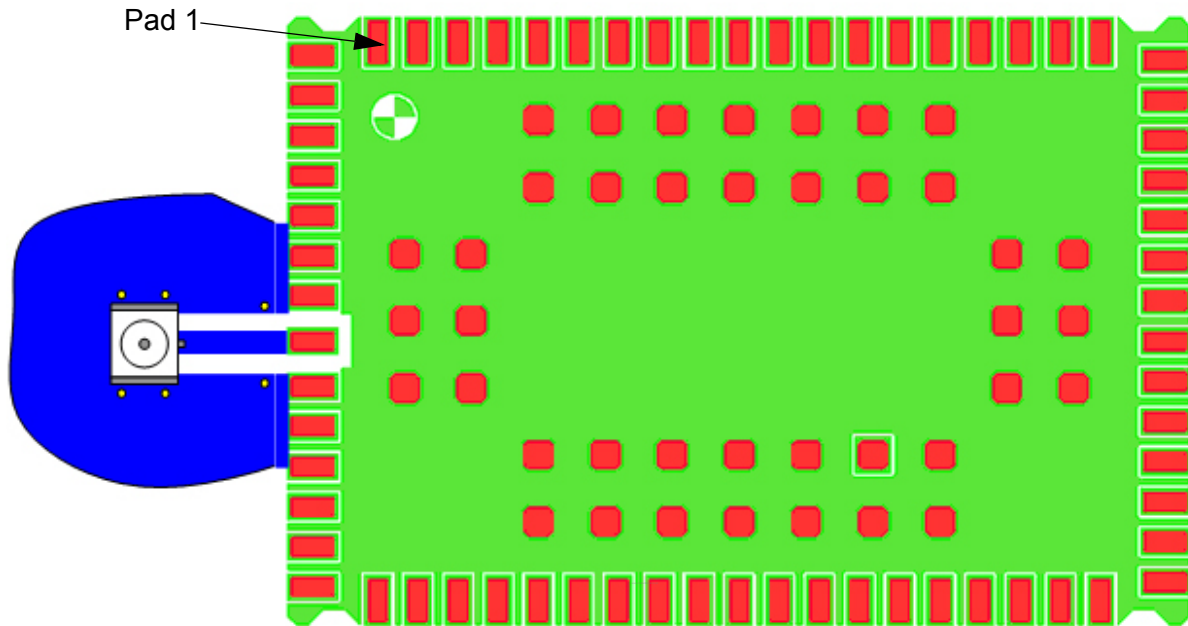

Figure 39: Routing to application's RF connector - top view

## 5 Electrical, Reliability and Radio Characteristics

### 5.1 Absolute Maximum Ratings

The absolute maximum ratings stated in [Table 18](#) are stress ratings under any conditions. Stresses beyond any of these limits will cause permanent damage to BGS2-E/BGS2-W.

**Table 18:** Absolute maximum ratings

Parameter	Min	Max	Unit
Supply voltage BATT+	-0.3	+6.0	V
Voltage at all digital lines in Power Down mode	-0.3	+0.3	V
Voltage at digital lines 1.8V domain in normal operation	-0.3	+2.2	V
Voltage at digital lines VDIG domain (1.8V) in normal operation	-0.3	+2.2	V
Voltage at digital lines VDIG domain (2.85V) in normal operation	-0.3	+3.3	V
Voltage at SIM interface, CCVCC 1.8V in normal Operation	-0.3	+2.2	V
Voltage at SIM interface, CCVCC 2.85V in normal Operation	-0.3	+3.3	V
Voltage at analog lines in normal operation	-0.3	+3.0	V
Voltage at analog lines in Power Down mode	-0.3	+0.3	V
VDDL	-0.3	+2.5	V

## 5.2 Operating Temperatures

Please note that the module's lifetime, i.e., the MTTF (mean time to failure) may be reduced, if operated outside the restricted temperature range. A special URC reports whether the module enters or leaves the restricted temperature range (see [1]; AT^SCTM).

**Table 19:** Board temperature

Parameter	Min	Typ	Max	Unit
Normal operation	-30	+25	+85	°C
Restricted operation	-40 to -30		+85 to +90	°C
Automatic shutdown <sup>1</sup> Temperature measured on BGS2-E/BGS2-W board	<-40	---	>+90	°C

1. Due to temperature measurement uncertainty, a tolerance of  $\pm 3^{\circ}\text{C}$  on the thresholds may occur.

**Table 20:** Ambient temperature according to IEC 60068-2 (w/o forced air circulation)

Parameter	Min	Typ	Max	Unit
GSM Call @ max. RF-Power	-40		+75	°C
GPRS Class 8 @ max. RF-Power	-40		+75	°C
GPRS Class 10 @ max. RF-Power (quad band only)	-40		+60	°C

**Table 21:** Ambient temperature with forced air circulation (air speed 0.9m/s)

Parameter	Min	Typ	Max	Unit
GSM Call @ max. RF-Power	-40		+80	°C
GPRS Class 8 @ max. RF-Power	-40		+80	°C
GPRS Class 10 @ max. RF-Power (quad band only)	-40		+70	°C

See also [Section 3.3.5.1](#) for information about the NTC for on-board temperature measurement, automatic thermal shutdown and alert messages.

Note that within the specified operating temperature ranges the board temperature may vary to a great extent depending on operating mode, used frequency band, radio output power and current supply voltage.

When data are transmitted over GPRS the quad band module variant automatically reverts to a lower Multislot Class if the temperature rises to the limit specified for normal operation and, vice versa, returns to the higher Multislot Class if the temperature is back to normal. For details see [Section 3.4](#).



## 5.3 Reliability Characteristics

The test conditions stated below are an extract of the complete test specifications.

**Table 22:** Summary of reliability test conditions

Type of test	Conditions	Standard
Vibration	Frequency range: 10-20Hz; acceleration: 5g Frequency range: 20-500Hz; acceleration: 20g Duration: 20h per axis; 3 axes	DIN IEC 60068-2-6 <sup>1</sup>
Shock half-sinus	Acceleration: 500g Shock duration: 1msec 1 shock per axis 6 positions ( $\pm$ x, y and z)	DIN IEC 60068-2-27
Dry heat	Temperature: $+70 \pm 2^{\circ}\text{C}$ Test duration: 16h Humidity in the test chamber: $< 50\%$	EN 60068-2-2 Bb ETS 300 019-2-7
Temperature change (shock)	Low temperature: $-40^{\circ}\text{C} \pm 2^{\circ}\text{C}$ High temperature: $+85^{\circ}\text{C} \pm 2^{\circ}\text{C}$ Changeover time: $< 30\text{s}$ (dual chamber system) Test duration: 1h Number of repetitions: 100	DIN IEC 60068-2-14 Na ETS 300 019-2-7
Damp heat cyclic	High temperature: $+55^{\circ}\text{C} \pm 2^{\circ}\text{C}$ Low temperature: $+25^{\circ}\text{C} \pm 2^{\circ}\text{C}$ Humidity: $93\% \pm 3\%$ Number of repetitions: 6 Test duration: 12h + 12h	DIN IEC 60068-2-30 Db ETS 300 019-2-5
Cold (constant exposure)	Temperature: $-40 \pm 2^{\circ}\text{C}$ Test duration: 16h	DIN IEC 60068-2-1

1. For reliability tests in the frequency range 20-500Hz the Standard's acceleration reference value was increased to 20g.

## 5.4 Pad Assignment and Signal Description

The SMT application interface on the BGS2-E/BGS2-W provides connecting pads to integrate the module into external applications. Figure 40 shows the connecting pads' numbering plan, the following Table 23 lists the pads' assignments.

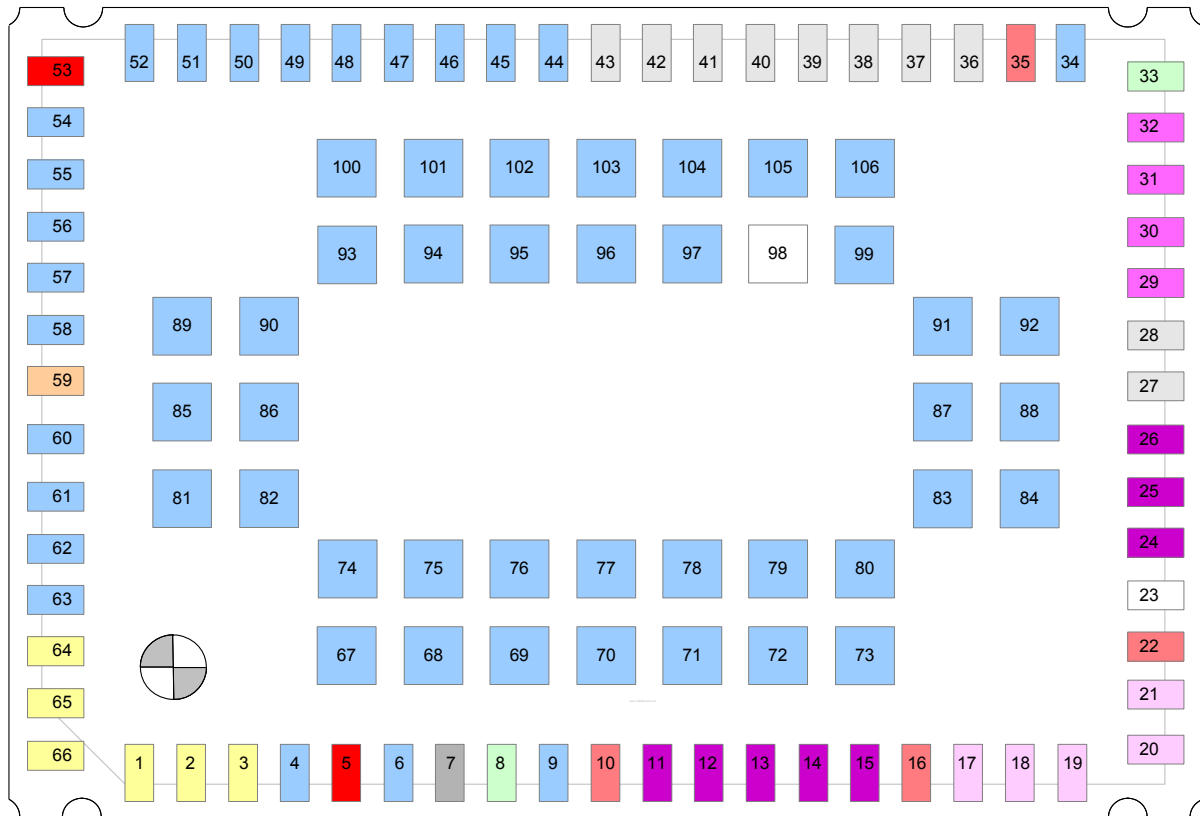

- |                    |                   |                |
|--------------------|-------------------|----------------|
| Supply pads: BATT+ | Analog audio pads | GPIO pads      |
| Supply pads: Other | ASC0 pads         | ADC pad        |
| Control pads       | ASC1 pads         | RF antenna pad |
| GND pads           | SIM pads          | Do not use     |

Figure 40: Numbering plan for connecting pads (bottom view)

**Table 23:** Pad assignments

Pad no.	Signal name	Pad no.	Signal name	Pad no.	Signal name
1	VMIC	23	Do not use	45	GND
2	EPN	24	DSR0	46	GND
3	EPP	25	DTR0	47	GND
4	GND	26	DCD0	48	GND
5	BATT+	27	GPIO9/I2CDAT	49	GND
6	GND	28	GPIO10/I2CCLK	50	GND
7	ADC1	29	TXD1	51	GND
8	ON	30	RXD1	52	GND
9	GND	31	RTS1	53	BATT+
10	VDIG	32	CTS1	54	GND
11	RXD0	33	EMERG_RST	55	GND
12	CTS0	34	GND	56	GND
13	TXD0	35	V180	57	GND
14	RING0	36	GPIO8	58	GND
15	RTS0	37	GPIO7/PWM1	59	RF_OUT
16	VDDL	38	GPIO6/PWM2	60	GND
17	CCRST	39	GPIO5/LED	61	GND
18	CCIN	40	GPIO4	62	GND
19	CCIO	41	GPIO3	63	GND
20	CCVCC	42	GPIO2	64	AGND
21	CCCLK	43	GPIO1	65	MICP
22	V285	44	GND	66	MICN
				67-106	GND <sup>1</sup>

1. The pads 67-106 are centrally located and should be connected to Ground **except** for pad 98 that is only required for factory tests. Pad 98 must not be connected to the external application, but should be left open.

Signal pads that are not used should not be connected to an external application.

Please note that the reference voltages listed in [Table 24](#) are the values measured directly on the BGS2-E/BGS2-W module. They do not apply to the accessories connected.

**Table 24:** Electrical description of application interface

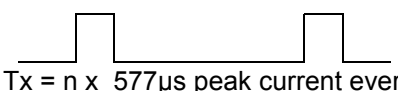
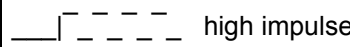
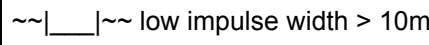
Function	Signal name	IO	Signal form and level	Comment
Power supply	BATT+	I	$V_{I\max} = 4.5V$ $V_{I\text{norm}} = 4.0V$ $V_{I\min} = 3.3V$ during Tx burst on board  $I \approx 1.35A$ , during Tx burst (GSM)   $n \text{ Tx} = n \times 577\mu s$ peak current every 4.616ms	Lines of BATT+ and GND must be connected in parallel for supply purposes because higher peak currents may occur.  Minimum voltage must not fall below 3.3V including drop, ripple, spikes.
Power supply	GND		Ground	Application Ground
External supply voltage	V180	O	Normal operation: $V_{O\text{norm}} = 1.80V \pm 3\%$ $I_{O\max} = -10mA$  SLEEP mode Operation: $V_{O\text{Sleep}} = 1.80V \pm 5\%$ $I_{O\max} = -10mA$  $CL_{\max} = 100nF$	V180 or V285 may be used for application circuits.  If unused keep line open.  Not available in Power Down mode. The external digital logic must not cause any spikes or glitches on voltage V180 or V285.
	V285	O	$V_{O\text{norm}} = 2.85V +1.5\%, -2\%$ $I_{O\max} = -10mA$  $CL_{\max} = 100nF$	
Ignition	ON	I	$R_I \approx 32k\Omega \pm 15\%$ , $C_I \approx 1nF$ $V_{IH\max} = V_{DDL P} + 0.5V$ $V_{IH\min} = 1.2V$ at $\sim 40\mu A$ $V_{IL\max} = 0.4V$   high impulse	This signal switches the module ON.  This line must be driven high by an open drain or open collector driver connected to VDDL P. See <a href="#">Section 3.3</a> .
Emergency restart	EMERG_RST	I	$R_I \approx 1k\Omega$ , $C_I \approx 1nF$ $V_{OH\max} = 1.9V$ $V_{IH\min} = 1.35V$ $V_{IL\max} = 0.3V$  $\sim\sim$  $\sim\sim$ low impulse width > 10ms	This line must be driven low by an open drain or open collector driver connected to GND.  If unused keep line open.
RTC backup	VDDL P	I/O	$V_{O\text{norm}} = 2.3V \pm 5\%$ $I_{O\max} = 2mA$  $V_{I\max} = 2.4V$ $V_{I\min} = 1.0V$ $I_{I\text{typ}} = 8\mu A$	It is recommended to use a serial resistor between VDDL P and a possible capacitor. See <a href="#">3.3.1.1</a> .  If unused keep line open.
SIM card detection	CCIN	I	$R_I \approx 110k\Omega$ $V_{IH\min} = 1.45V$ at $I = 15\mu A$ , $V_{IH\max} = 1.9V$ $V_{IL\max} = 0.3V$	CCIN = High, SIM card inserted.  If unused keep line open.

**Table 24:** Electrical description of application interface

Function	Signal name	IO	Signal form and level	Comment
3V SIM Card Interface	CCRST	O	$V_{OLmax} = 0.20V$ at $I = 2mA$ $V_{OHmin} = 2.40V$ at $I = -2mA$ $V_{OHmax} = 2.90V$	Maximum cable length or copper track to SIM card holder should not exceed 100mm.
	CCIO	I/O	$V_{ILmax} = 0.60V$ $V_{IHmin} = 1.95V$ $V_{IHmax} = 2.90V$  $V_{OLmax} = 0.20V$ at $I = 2mA$ $V_{OHmin} = 2.40V$ at $I = -2mA$ $V_{OHmax} = 2.90V$	
	CCCLK	O	$V_{OLmax} = 0.20V$ at $I = 2mA$ $V_{OHmin} = 2.40V$ at $I = -2mA$ $V_{OHmax} = 2.90V$	
	CCVCC	O	$V_{Omin} = 2.80V$ $V_{Otyp} = 2.85V$ $V_{Omax} = 2.90V$ $I_{Omax} = -30mA$	
1.8V SIM Card Interface	CCRST	O	$V_{OLmax} = 0.20V$ at $I = 2mA$ $V_{OHmin} = 1.50V$ at $I = -2mA$ $V_{OHmax} = 1.90V$	
	CCIO	I/O	$V_{ILmax} = 0.37V$ $V_{IHmin} = 1.22V$ $V_{IHmax} = 1.90V$  $V_{OLmax} = 0.20V$ at $I = 2mA$ $V_{OHmin} = 1.50V$ at $I = -2mA$ $V_{OHmax} = 1.90V$	
	CCCLK	O	$V_{OLmax} = 0.20V$ at $I = 2mA$ $V_{OHmin} = 1.50V$ at $I = -2mA$ $V_{OHmax} = 1.90V$	
	CCVCC	O	$V_{Omin} = 1.75V$ $V_{Otyp} = 1.80V$ $V_{Omax} = 1.85V$ $I_{Omax} = -30mA$	

**Table 24:** Electrical description of application interface

Function	Signal name	IO	Signal form and level	Comment
Digital Power Supply	VDIG	I	$V_{Imin} = 1.75V$ $V_{Imax} = 2.90V$ $I_{Imax} = 50mA$	ASC0 and I <sup>2</sup> C power supply input.  Connect this line to the external power supply voltage V180 or V285. See also <a href="#">Section 3.9</a> .
Serial Interface ASC0	<i>VDIG connected to V180, i.e., VDIG = 1.80V</i>			If unused keep line open.
	RXD0	O	$V_{OLmax} = 0.20V$ at $I = 2mA$ $V_{OHmin} = 1.50V$ at $I = -2mA$ $V_{OHmax} = 1.90V$	
	TXD0	I		
	CTS0	O	$V_{ILmax} = 0.34V$ $V_{IHmin} = 1.30V$ $V_{IHmax} = 1.90V$	
	DTR0	I		
	DSR0	O		
	DCD0	O		
	RTS0	I	$V_{ILmax} = 0.20V$ at $I = -280\mu A$ $V_{IHmin} = 1.20V$ at $I = -160\mu A$ $V_{IHmax} = 1.90V$	
	RING0	O	$V_{OLmax} = 0.30V$ at $I = 2mA$ $V_{OHmin} = 1.40V$ at $I = -40\mu A$ $V_{OHmax} = 1.90V$	
	<i>VDIG connected to V285, i.e., VDIG = 2.85V</i>			
	RXD0	O	$V_{OLmax} = 0.20V$ at $I = 2mA$ $V_{OHmin} = 2.40V$ at $I = -2mA$ $V_{OHmax} = 2.90V$	
	TXD0	I		
	CTS0	O	$V_{ILmax} = 0.56V$ $V_{IHmin} = 2.05V$ $V_{IHmax} = 2.90V$	
	DTR0	I		
	DSR0	O		
	DCD0	O		
RTS0	I	$V_{ILmax} = 0.30V$ at $I = -380\mu A$ $V_{IHmin} = 1.96V$ at $I = -80\mu A$ $V_{IHmax} = 2.90V$		
RING0	O	$V_{OLmax} = 0.30V$ at $I = 2mA$ $V_{OHmin} = 2.40V$ at $I = -40\mu A$ $V_{OHmax} = 2.90V$		
Serial Interface ASC1	RXD1	O	$V_{OLmax} = 0.20V$ at $I = 2mA$ $V_{OHmin} = 1.50V$ at $I = -2mA$ $V_{OHmax} = 1.90V$	If unused keep line open.
	TXD1	I		
	RTS1	I	$V_{ILmax} = 0.34V$ $V_{IHmin} = 1.30V$ $V_{IHmax} = 1.90V$	
	CTS1	O		

**Table 24:** Electrical description of application interface

Function	Signal name	IO	Signal form and level	Comment
I <sup>2</sup> C	<i>VDIG connected to V180, i.e., VDIG = 1.80V</i>			I2CDAT is configured as Open Drain and needs a pull-up resistor in the host application.
	I2CCLK	O	V <sub>OL</sub> min = 0.4V at I = -3mA	
	I2CDAT	IO	V <sub>IL</sub> max = 0.5V V <sub>IH</sub> min = 1.3V V <sub>IH</sub> max = 2.25V  Rpullup >= 470 Ohm	According to the I <sup>2</sup> C Bus Specification Version 2.1 for the fast mode a rise time of max. 300ns is permitted. There is also a maximum V <sub>OL</sub> =0.4V at 3mA specified.  The value of the pull-up depends on the capacitive load of the whole system (I <sup>2</sup> C Slave + lines). The maximum sink current of I2CDAT and I2CCLK is 4mA.  If lines are unused keep lines open.
	<i>VDIG connected to V285, i.e., VDIG = 2.85V</i>			
	I2CCLK	O	V <sub>OL</sub> min = 0.4V at I = -3mA	
	I2CDAT	IO	V <sub>IL</sub> max = 0.8V V <sub>IH</sub> min = 2.1V V <sub>IH</sub> max = 3.3V  Rpullup >= 820 Ohm	

**Table 24:** Electrical description of application interface

Function	Signal name	IO	Signal form and level	Comment
GPIO interface	GPIO1	IO	$V_{OLmax} = 0.20V$ at $I = 2mA$ $V_{OHmin} = 1.50V$ at $I = -2mA$ $V_{OHmax} = 1.90V$ $V_{ILmax} = 0.34V$ $V_{IHmin} = 1.30V$ $V_{IHmax} = 1.90V$	If unused keep line open.  Please note that some GPIO lines can be used for functions other than GPIO: Status LED line: GPIO5, PWM: GPIO6/GPIO7, I <sup>2</sup> C: GPIO9/GPIO10.  GPIO9 has an open drain output functionality only and will need an external pull-up resistor. With VDIG connected to V180 the minimum value of this external resistor should be 750Ohm. With VDIG connected to V285 the minimum value should be 1.1kOhm.
	GPIO2	IO		
	GPIO3	IO		
	GPIO4	IO		
	GPIO5	IO		
	GPIO6	IO		
	GPIO7	IO		
	GPIO8	IO		
	<i>VDIG connected to V180, i.e., VDIG = 1.80V</i>			
	GPIO9, i.e., I2CDAT	IO	Input, Open Drain Output (no Pull up) $V_{ILmax} = 0.5V$ $V_{IHmin} = 1.3V$ $V_{IHmax} = 2.20V$ $V_{OLmin} = 0.4V$ at $I = -3mA$	GPIO10 also has an open drain output functionality only, but with an internal 5kOhm pull up. With VDIG connected to V180 the minimum value of this external resistor should be 860Ohm. With VDIG connected to V285 the minimum value should be 1.5kOhm.
GPIO10, i.e., I2CCLK	IO	Input, Open Drain Output $R_I \approx 5kOhm$ ( internal Pull up) $V_{OLmin} = 0.4V$ at $I = -3mA$ $V_{OHmax} = 1.90V$		
<i>VDIG connected to V285, i.e., VDIG = 2.85V</i>				
GPIO9, i.e., I2CDAT	IO	Input, Open Drain Output (no Pull up) $V_{ILmax} = 0.8V$ $V_{IHmin} = 2.1V$ $V_{IHmax} = 3.3V$ $V_{OLmin} = 0.4V$ at $I = -3mA$		
GPIO10, i.e., I2CCLK	IO	Open Drain Output $R_I \approx 5kOhm$ ( internal Pull up) $V_{OLmin} = 0.4V$ at $I = -3mA$ $V_{OHmax} = 2.90V$	For further details see <a href="#">Section 3.12</a> , <a href="#">Section 3.13</a> , <a href="#">Section 3.14</a> , <a href="#">Section 3.15</a> .	



**Table 24:** Electrical description of application interface

Function	Signal name	IO	Signal form and level	Comment
Analog audio interface	VMIC	O	$V_{Otyp} = 2.2V$ $I_{max} = 4\text{ mA}$	Microphone supply for customer feeding circuits  If unused keep line open.
	EPP	O	Differential, Typ. 3.4Vpp at 16Ω load Typ. 4.5Vpp at no load PCM level = +3dBm0, 1.02 kHz sine wave	Balanced output for ear-phone or balance output for line out  If unused keep line open.
	EPN	O		
	MICP	I	$Z_{Ityp} = 50k\Omega$ $V_{inmax} = 0.8V_{pp}$ (for 3dBm0 @ 0dB gain)	Balanced differential microphone with external feeding circuit (using VMIC and AGND) or balanced differential line input.  Use coupling capacitors. If unused keep lines open.
	MICN	I		
	AGND		Analog Ground	GND level for external audio circuits. If unused keep line open.
ADC	ADC1	I	$R_I = 1M\Omega$ $V_I = 0V \dots 1.2V$ $V_{IH\text{ max}} = 3.3V$	If unused keep line open.

## 5.5 Power Supply Ratings

Table 25: Power supply ratings<sup>1</sup>

Parameter	Description	Conditions	Min	Typ	Max	Unit
BATT+	Supply voltage	Voltage must stay within the min/max values, including voltage drop, ripple and spikes.	3.3	4.0	4.5	V
	Voltage drop during transmit burst	Normal condition, power control level for P <sub>out max</sub>			400	mV
	Voltage ripple	Normal condition, power control level for P <sub>out max</sub> @ f<250kHz @ f>250kHz			85 25	mVpp
I <sub>VDDL</sub>	OFF state supply current	RTC backup @ BATT+ = 0V @ VDDL = 2.3V		8.0		µA
		Power Down mode		45		µA
I <sub>BATT+</sub>	Average supply current	SLEEP mode, GSM <sup>2</sup> @ DRX = 2 @ DRX = 5 @ DRX = 9		2.1 1.5 1.1		mA
		SLEEP mode, GPRS <sup>2</sup> @ DRX = 2 @ DRX = 5 @ DRX = 9		2.2 1.5 1.2		mA
		IDLE mode <sup>2</sup>		8.6		mA
		TALK mode GSM GSM850/EGSM 900 <sup>3</sup> GSM 1800/1900 <sup>4</sup>		200 150		mA
		DATA mode GPRS 1 TX, 4 Rx GSM 850/EGSM 900 <sup>3</sup> GSM 1800/1900 <sup>4</sup>		180 145		mA
		DATA mode GPRS 2 Tx, 3 Rx GSM 850/EGSM 900 <sup>3</sup> GSM 1800/1900 <sup>4</sup>		330 260		mA
	Peak supply current (during transmission slot every 4.6ms)	Power Control Level GSM 850/EGSM 900 <sup>3</sup> GSM 1800/1900 <sup>4</sup>		1.30 0.95	1.35 0.97	A

1. GSM850 and GSM1900 bands are applicable for the quad band module variant BGS2-W only.
2. Measurements start 3 minutes after the module was switched ON,  
Averaging times: SLEEP mode - 3 minutes; IDLE mode - 1.5 minutes,  
Communication tester settings: no neighbour cells, no cell reselection etc.
3. Power control level PCL 5
4. Power control level PCL 0

## 5.6 Electrical Characteristics of the Voiceband Part

### 5.6.1 Setting Audio Parameters by AT Commands

The audio modes 2 to 6 can be adjusted according to the parameters listed below. Each audio mode is assigned a separate set of parameters.

**Table 26:** Audio parameters adjustable by AT command

Parameter	Influence to	Range	Gain range	Calculation
inBbcGain	MICP/MICN analog amplifier gain of baseband controller before ADC	0...7	0...39dB	6dB steps, 3dB between step 6 and 7
inCalibrate	Digital attenuation of input signal after ADC	0...32767	$-\infty$ ...0dB	$20 * \log(\text{inCalibrate}/32768)$
outBbcGain	EPP/EPN analog output gain of baseband controller after DAC	0...3	0...-18dB	6dB steps
outCalibrate[n] n = 0...4	Digital attenuation of output signal after speech decoder, before summation of sidetone and DAC present for each volume step[n]	0...32767	$-\infty$ ...+6dB	$20 * \log(2 * \text{outCalibrate}[n]/32768)$
sideTone	Digital attenuation of sidetone is corrected internally by outBbcGain to obtain a constant sidetone independent of output volume	0...32767	$-\infty$ ...0dB	$20 * \log(\text{sideTone}/32768)$

*Note: The parameters inCalibrate, outCalibrate and sideTone accept also values from 32768 to 65535. These values are internally truncated to 32767.*

### 5.6.2 Audio Programming Model

The audio programming model shows how the signal path can be influenced by varying the AT command parameters.

The parameters *<inBbcGain>* and *<inCalibrate>* can be set with AT^SNFI. All the other parameters are adjusted with AT^SNFO.

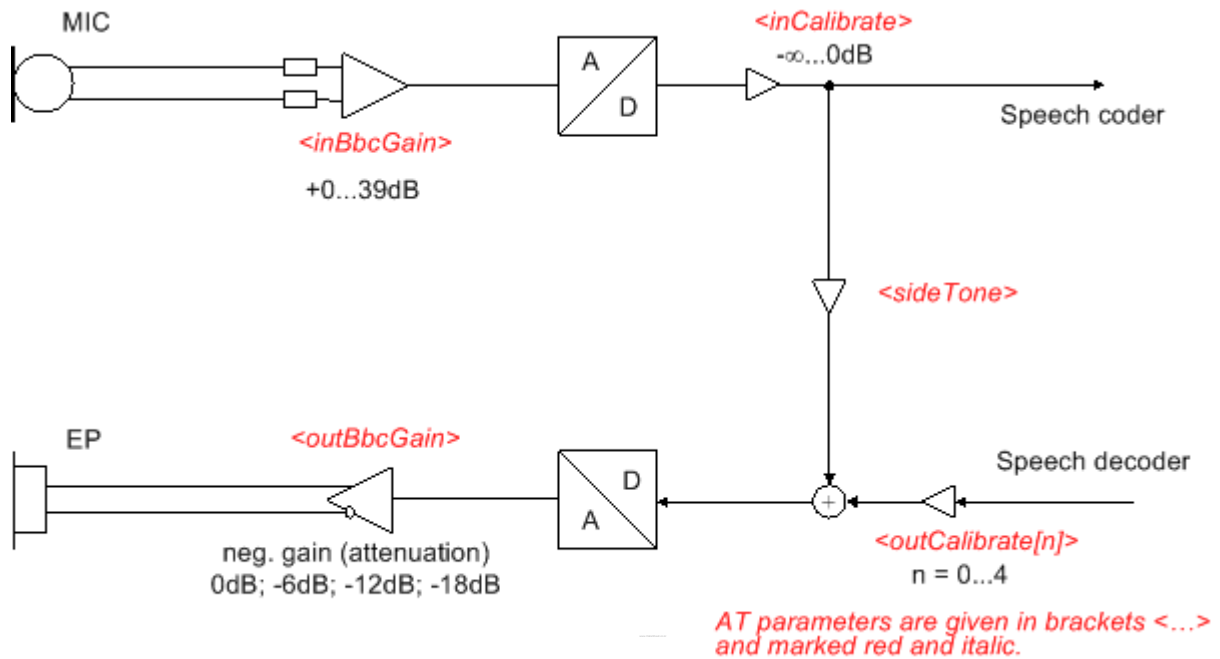

Figure 41: Audio programming model

### 5.6.3 Characteristics of Audio Modes

The electrical characteristics of the voiceband part depend on the current audio mode set with the AT^SNFS command.

**Table 27:** Voiceband characteristics (typical)

Audio mode no. AT^SNFS=	1 (Default settings, not adjustable)	2	3	4	5	6
Name	Default Handset	Basic Handsfree	Headset	User Handset	Plain Codec 1	Plain Codec 2
Purpose	DSB with Votronic handset	Car Kit	Headset	DSB with individual handset	Direct access to speech coder	Direct access to speech coder
Gain setting via AT command. Defaults: inBbcGain outBbcGain	Fix 4 (24dB) 0 (0dB)	Adjustable 1 (6dB) 2 (-12dB)	Adjustable 6 (36dB) 2 (-12dB)	Adjustable 4 (24dB) 0 (0dB)	Adjustable 0 (0dB) 0 (0dB)	Adjustable 0 (0dB) 0 (0dB)
Power supply	ON (2.2V)	ON (2.2V)	ON (2.2V)	ON (2.2V)	ON (2.2V)	ON (2.2V)
Sidetone	ON	--	Adjustable	Adjustable	Adjustable	Adjustable
Volume control	OFF	Adjustable	Adjustable	Adjustable	Adjustable	Adjustable
Echo control (send)	Cancellation	Cancellation	Cancellation	Cancellation	Cancellation	Cancellation
Noise suppression <sup>1</sup>	12dB	12dB	12dB	12dB	--	--
MIC input signal for 0dBm0 @ 1024 Hz (default gain)	16mV	130mV	7.5mV <sup>2</sup>	16mV	275mV	275mV
EP output signal in mV rms. @ 0dBm0, 1024 Hz, no load (default gain); @ 3.14 dBm0	500mV	160mV	230mV	500mV	1160mV 4.5Vpp	1160mV 4.5Vpp
Sidetone gain at default settings	20dB	-∞	17dB	20dB	-∞	-∞

1. In audio modes with noise reduction, the microphone input signal for 0dBm0 shall be measured with a sine burst signal for a tone duration of 5 seconds and a pause of 2 sec. The sine signal appears as noise and, after approx. 12 sec, is attenuated by the noise reduction by up to 12dB.

2. Signal for -2dBm0 (due to attenuation of uplink filter at 1kHz)

*Note: With regard to acoustic shock, the cellular application must be designed to avoid sending false AT commands that might increase amplification, e.g. for a high sensitive earpiece. A protection circuit should be implemented in the cellular application.*

### 5.6.4 Voiceband Receive Path

*Test conditions:*

- The values specified below were tested to 1kHz and 0dB gain stage, unless otherwise stated.
- Parameter setup: gs = 0dB means audio mode = 5 for EPP to EPN, inBbcGain= 0, inCalibrate = 32767, outBbcGain = 0, OutCalibrate = 16384, sideTone = 0.

**Table 28:** Voiceband receive path

Parameter	Min	Typ	Max	Unit	Test condition/remark
Differential output voltage (peak to peak)		3.4 4.5		Vpp	16Ohm, no load, from EPPx to EPNx gs = 0dB @ 3.14dBm0
Differential output gain settings (gs) at 6dB stages (outBbcGain)	-18		0	dB	Set with AT^SNFO
Fine scaling by DSP (outCalibrate)	-∞		+6	dB	Set with AT^SNFO
Output differential DC offset	-50		+50	mV	gs = 0dB, outBbcGain = 0 and -6dB
Differential output load resistance	14			Ω	from EPP to EPN
Allowed single ended load capacitance			150	pF	from EPP or EPN to AGND
Absolute gain drift	-5		+5	%	Variation due to change in temperature and life time
Passband ripple			0.5	dB	for f < 3600 Hz
Stopband attenuation	50			dB	for f > 4600 Hz

gs = gain setting

## 5.6.5 Voiceband Transmit Path

### Test conditions:

- The values specified below were tested to 1kHz and 0dB gain stage, unless otherwise stated.
- Parameter setup: Audio mode = 5 for MICP to MICN, inBbcGain= 0, inCalibrate = 32767, outBbcGain = 0, OutCalibrate = 16384, sideTone = 0

**Table 29:** Voiceband transmit path

Parameter	Min	Typ	Max	Unit	Test condition/Remark
Input voltage (peak to peak) MICP to MICN			0.8	V	
Input amplifier gain in 6dB steps (inBbcGain) <sup>1</sup>	0		39	dB	Set with AT^SNFI
Fine scaling by DSP (inCalibrate)	-∞		0	dB	Set with AT^SNFI
Input impedance MIC		50		kΩ	
Microphone supply voltage		2.2		V	
Microphone supply current			4	mA	

1. 3dB step between inBbcGain 6 and 7.

## 5.7 Antenna Interface Specification

Measurement conditions:  $T_{amb} = 25^{\circ}\text{C}$ ,  $V_{BATT+nom} = 4.1\text{V}$ .

**Table 30:** Antenna interface specifications<sup>1</sup>

Parameter		Min	Typ	Max	Unit
Frequency range Uplink (MS → BTS)	GSM 850	824		849	MHz
	E-GSM 900	880		915	MHz
	GSM 1800	1710		1785	MHz
	GSM 1900	1850		1910	MHz
Frequency range Downlink (BTS → MS)	GSM 850	869		894	MHz
	E-GSM 900	925		960	MHz
	GSM 1800	1805		1880	MHz
	GSM 1900	1930		1990	MHz
Receiver input sensitivity @ ARP Under all propagation conditions according to GSM specification	GSM 850	-102			dBm
	E-GSM 900	-102			dBm
	GSM 1800	-102			dBm
	GSM 1900	-102			dBm
Receiver input sensitivity @ ARP BER Class II <= 2.43% @ static input level (no fading)	GSM 850		-107		dBm
	E-GSM 900		-107		dBm
	GSM 1800		-107		dBm
	GSM 1900		-107		dBm
RF power @ ARP with 50Ω load	GSM 850	31	33	35	dBm
	E-GSM 900	31	33	35	dBm
	GSM 1800	28	30	32	dBm
	GSM 1900	28	30	32	dBm

1. GSM850 and GSM1900 bands are applicable for the quad band module variant BGS2-W only.



## 5.8 Electrostatic Discharge

The GSM module is not protected against Electrostatic Discharge (ESD) in general. Consequently, it is subject to ESD handling precautions that typically apply to ESD sensitive components. Proper ESD handling and packaging procedures must be applied throughout the processing, handling and operation of any application that incorporates a BGS2-E/BGS2-W module.

*Special ESD protection provided on BGS2-E/BGS2-W:*

- SIM interface: Serial resistor and ESD protection diode

BGS2-E/BGS2-W has been tested according to group standard ETSI EN 301 489-1 (see [Table 3](#)) and test standard EN 61000-4-2. The measured values can be gathered from the following table.

**Table 31:** Measured electrostatic values

Specification/Requirements	Contact discharge	Air discharge
<b>EN 61000-4-2</b>		
SIM interface	± 4kV	± 8kV
Antenna interface	± 4kV	± 8kV
<b>JEDEC JESD22-A114D</b> (Human Body Model, Test conditions: 1.5 kΩ, 100 pF)		
ESD at the module	± 1kV	n.a.

*Note: Please note that the values may vary with the individual application design. For example, it matters whether or not the application platform is grounded over external devices like a computer or other equipment, such as the Cinterion reference application described in [Chapter 8](#).*

## 6 Mechanics, Mounting and Packaging

The following sections describe the mechanical dimensions of BGS2-E/BGS2-W and give recommendations for integrating BGS2-E/BGS2-W into the host application. Also, a number of files containing product model data in STEP format as well as Gerber data for the external application footprint are attached to this PDF. Please open the [Attachments](#) navigation panel to view and save these files.

### 6.1 Mechanical Dimensions of BGS2-E/BGS2-W

[Figure 42](#) shows the top and bottom view of BGS2-E/BGS2-W and provides an overview of the board's mechanical dimensions. For further details see [Figure 43](#).

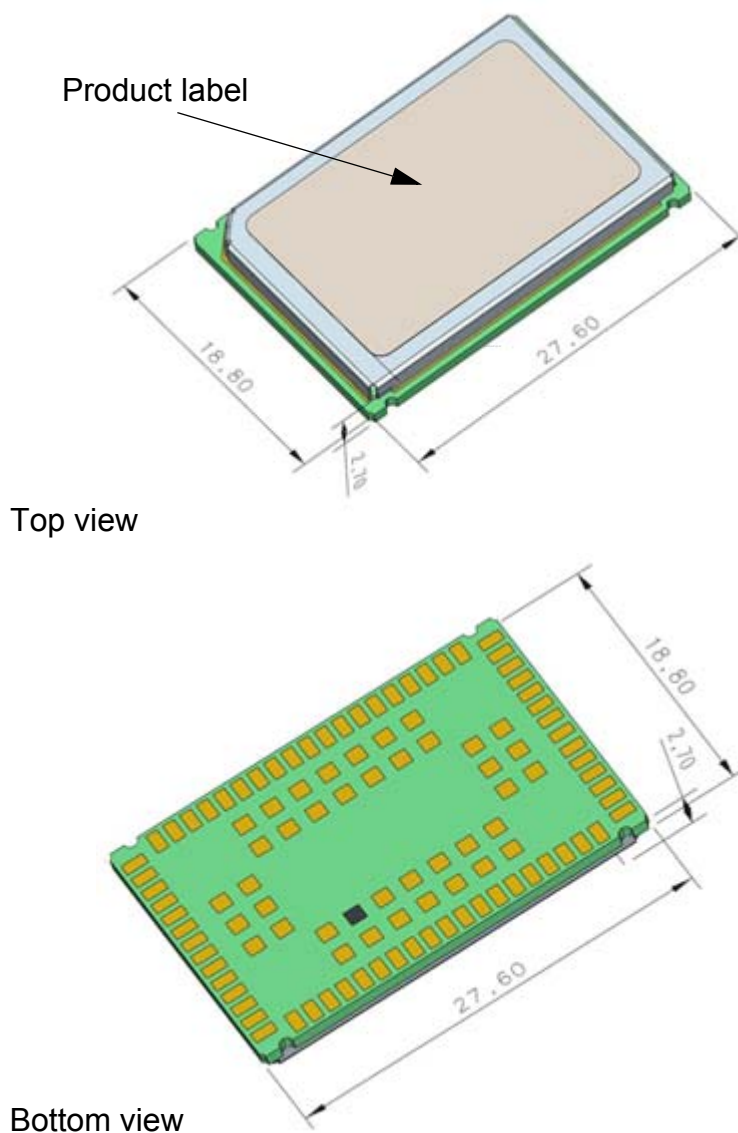

**Figure 42:** BGS2-E/BGS2-W– top and bottom view





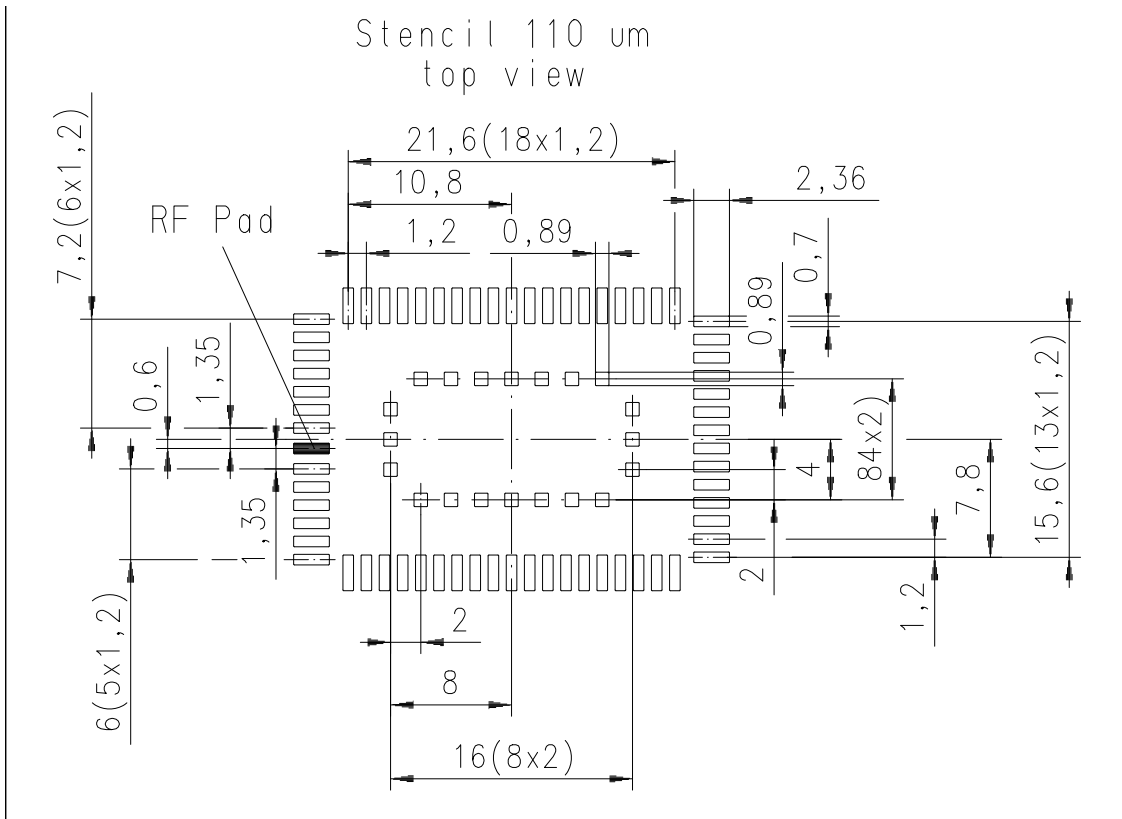

Figure 45: Recommended design for 110 micron thick stencil (top view)

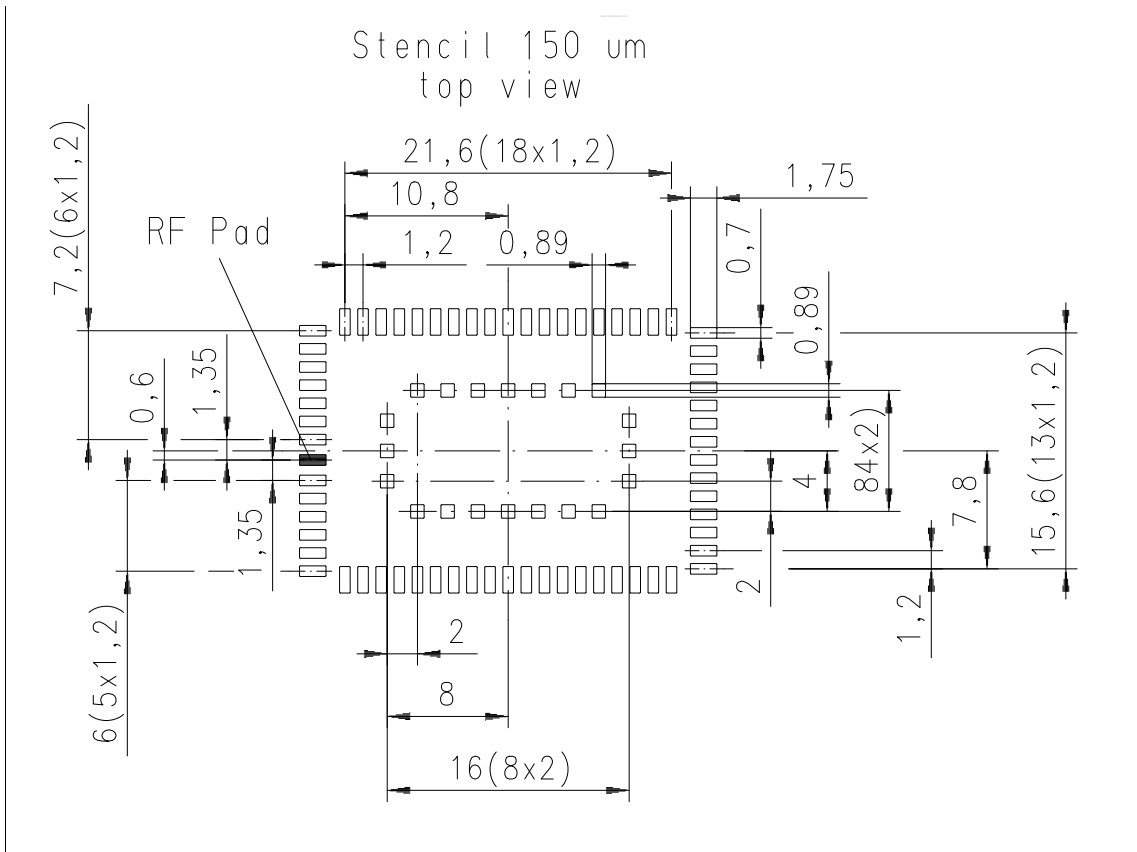

Figure 46: Recommended design for 150 micron thick stencil (top view)

### 6.2.1.2 Board Level Characterization

Board level characterization issues should also be taken into account if devising an SMT process.

Characterization tests should attempt to optimize the SMT process with regard to board level reliability. This can be done by performing the following physical tests on sample boards: Peel test, bend test, tensile pull test, drop shock test and temperature cycling. Sample surface mount checks are described in [\[3\]](#).

It is recommended to characterize land patterns before an actual PCB production, taking individual processes, materials, equipment, stencil design, and reflow profile into account. For land and stencil pattern design recommendations see also [Section 6.2.1.1](#). Optimizing the solder stencil pattern design and print process is necessary to ensure print uniformity, to decrease solder voids, and to increase board level reliability.

Daisy chain modules for SMT characterization are available on request. For details refer to [\[3\]](#).

Generally, solder paste manufacturer recommendations for screen printing process parameters and reflow profile conditions should be followed. Maximum ratings are described in [Section 6.2.3](#).

## 6.2.2 Moisture Sensitivity Level

BGS2-E/BGS2-W comprises components that are susceptible to damage induced by absorbed moisture.

Cinterion's BGS2-E/BGS2-W module complies with the latest revision of the IPC/JEDEC J-STD-020 Standard for moisture sensitive surface mount devices and is classified as MSL 4.

For additional MSL (=moisture sensitivity level) related information see [Section 6.2.4](#) and [Section 6.3.2](#).

### 6.2.3 Soldering Conditions and Temperature

#### 6.2.3.1 Reflow Profile

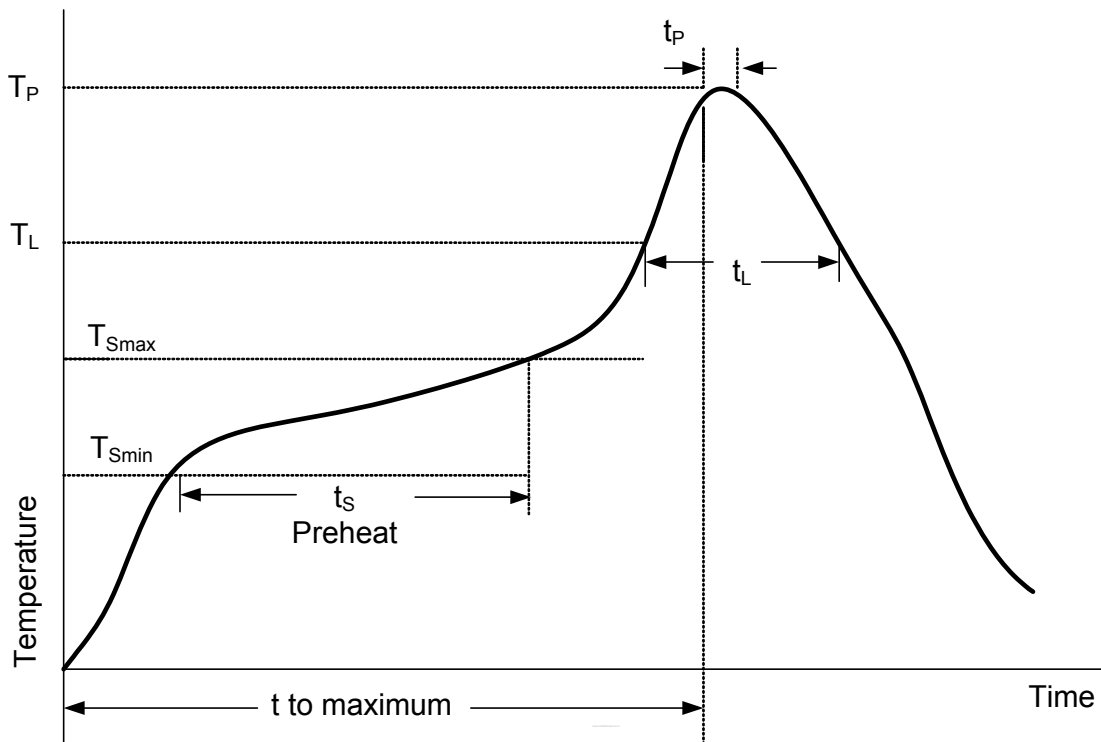

Figure 47: Reflow Profile

Table 32: Reflow temperature ratings

Profile Feature	Pb-Free Assembly
Preheat & Soak Temperature Minimum ( $T_{Smin}$ ) Temperature Maximum ( $T_{Smax}$ ) Time ( $t_{Smin}$ to $t_{Smax}$ ) ( $t_s$ )	150°C 200°C 60-120 seconds
Average ramp up rate ( $T_{Smax}$ to $T_P$ )	3K/second max.
Liquidous temperature ( $T_L$ ) Time at liquidous ( $t_l$ )	217°C 60-90 seconds
Peak package body temperature ( $T_P$ )	245°C +0/-5°C
Time ( $t_p$ ) within 5 °C of the peak package body temperature ( $T_P$ )	30 seconds max.
Average ramp-down rate ( $T_P$ to $T_{Smax}$ )	6 K/second max.
Time 25°C to maximum temperature	8 minutes max.

#### 6.2.3.2 Maximum Temperature and Duration

The following limits are recommended for the SMT board-level soldering process to attach the module:

- A maximum module temperature of 245°C. This specifies the temperature as measured at the module's top side.
- A maximum duration of 30 seconds at this temperature.

Please note that while the solder paste manufacturers' recommendations for best temperature and duration for solder reflow should generally be followed, the limits listed above must not be exceeded.

BGS2-E/BGS2-W is specified for one soldering cycle only. Once BGS2-W is removed from the application, the module will very likely be destroyed and cannot be soldered onto another application.



## 6.2.4 Durability and Mechanical Handling

### 6.2.4.1 Storage Conditions

BGS2-E/BGS2-W modules, as delivered in tape and reel carriers, must be stored in sealed, moisture barrier anti-static bags. The conditions stated below are only valid for modules in their original packed state in weather protected, non-temperature-controlled storage locations. Normal storage time under these conditions is 12 months maximum.

**Table 33:** Storage conditions

Type	Condition	Unit	Reference
Air temperature: Low High	-25 +40	°C	IPC/JEDEC J-STD-033A
Humidity relative: Low High	10 90 at 40°C	%	IPC/JEDEC J-STD-033A
Air pressure: Low High	70 106	kPa	IEC TR 60271-3-1: 1K4 IEC TR 60271-3-1: 1K4
Movement of surrounding air	1.0	m/s	IEC TR 60271-3-1: 1K4
Water: rain, dripping, icing and frosting	Not allowed	---	---
Radiation: Solar Heat	1120 600	W/m <sup>2</sup>	ETS 300 019-2-1: T1.2, IEC 60068-2-2 Bb ETS 300 019-2-1: T1.2, IEC 60068-2-2 Bb
Chemically active substances	Not recommended	---	IEC TR 60271-3-1: 1C1L
Mechanically active substances	Not recommended	---	IEC TR 60271-3-1: 1S1
Vibration sinusoidal: Displacement Acceleration Frequency range	1.5 5 2-9 9-200	mm m/s <sup>2</sup> Hz	IEC TR 60271-3-1: 1M2
Shocks: Shock spectrum Duration Acceleration	semi-sinusoidal 1 50	ms m/s <sup>2</sup>	IEC 60068-2-27 Ea

#### 6.2.4.2 Processing Life

BGS2-E/BGS2-W must be soldered to an application within 72 hours after opening the MBB (=moisture barrier bag) it was stored in.

As specified in the IPC/JEDEC J-STD-033 Standard, the manufacturing site processing the modules should have ambient temperatures below 30°C and a relative humidity below 60%.

#### 6.2.4.3 Baking

Baking conditions are specified on the moisture sensitivity label attached to each MBB (see [Figure 52](#) for details):

- It is *not necessary* to bake BGS2-E/BGS2-W, if the conditions specified in [Section 6.2.4.1](#) and [Section 6.2.4.2](#) were not exceeded.
- It is *necessary* to bake BGS2-E/BGS2-W, if any condition specified in [Section 6.2.4.1](#) and [Section 6.2.4.2](#) was exceeded.

If baking is necessary, the modules must be put into trays that can be baked to at least 125°C. Devices should not be baked in tape and reel carriers at any temperature.

#### 6.2.4.4 Electrostatic Discharge

ESD (=electrostatic discharge) may lead to irreversable damage for the module. It is therefore advisable to develop measures and methods to counter ESD and to use these to control the electrostatic environment at manufacturing sites.

Please refer to [Section 5.8](#) for further information on electrostatic discharge.

## 6.3 Packaging

### 6.3.1 Tape and Reel

The single-feed tape carrier for BGS2-E/BGS2-W is illustrated in Figure 48. The figure also shows the proper part orientation. The tape width is 44 mm and the BGS2-W modules are placed on the tape with a 28-mm pitch. The reels are 330 mm in diameter with a core diameter of 100 mm. Each reel contains 500 modules.

#### 6.3.1.1 Orientation

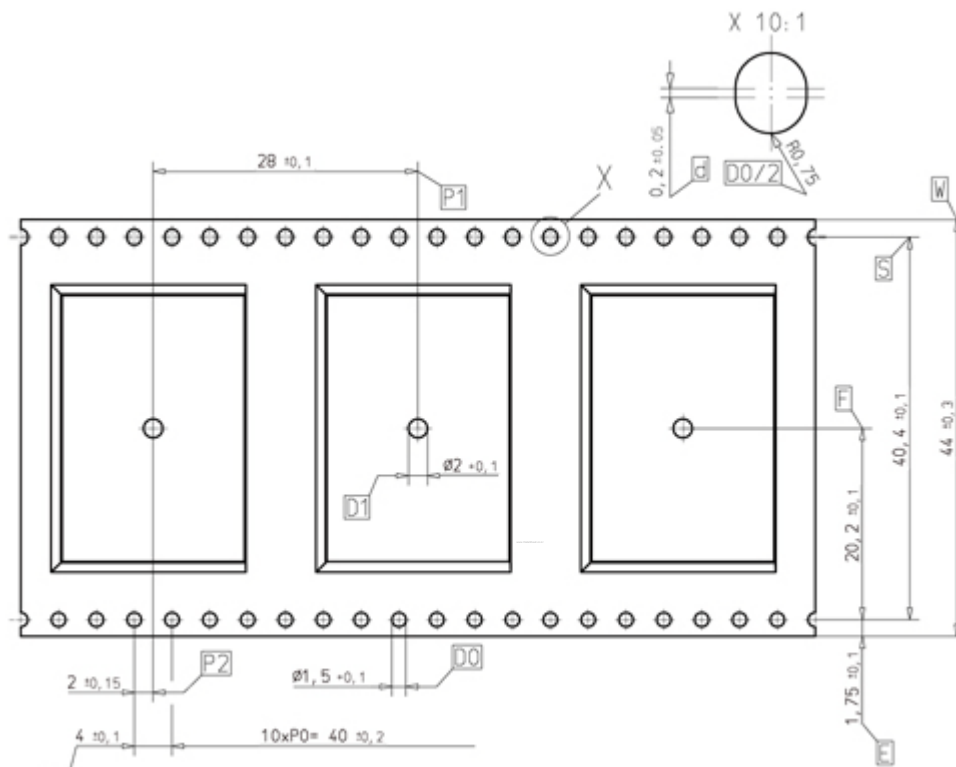

Figure 48: Carrier tape

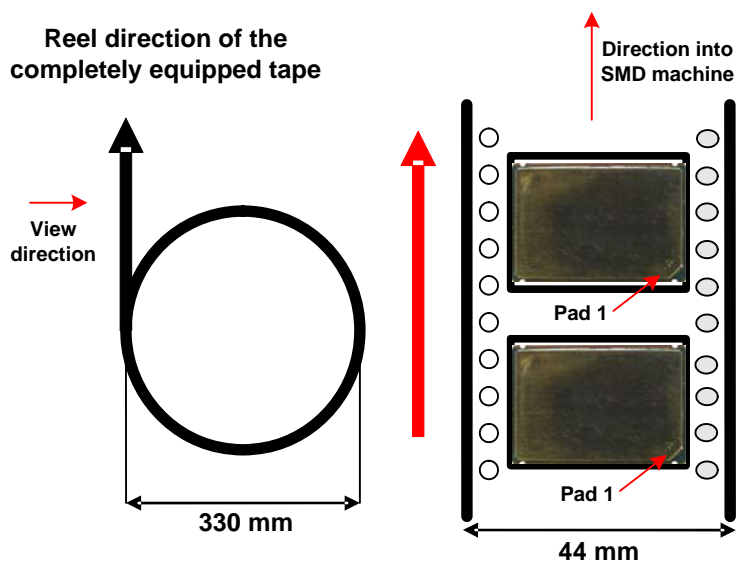

Figure 49: Reel direction

### 6.3.1.2 Barcode Label

A barcode label provides detailed information on the tape and its contents. It is attached to the reel.

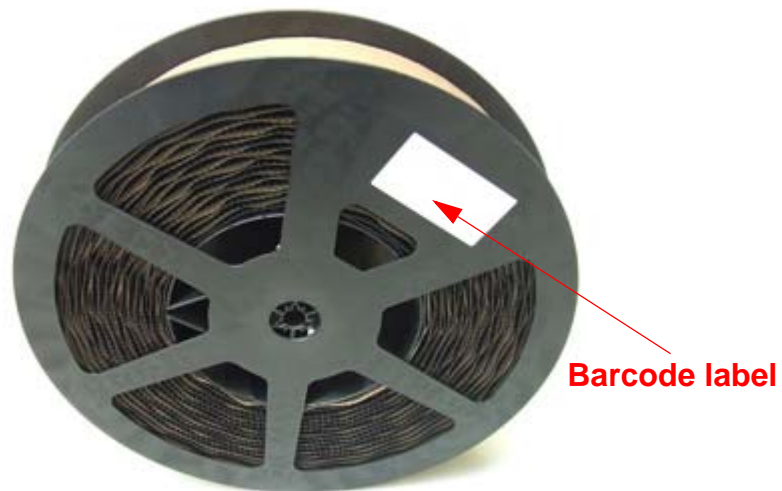

Figure 50: Barcode label on tape reel

## 6.3.2 Shipping Materials

BGS2-E/BGS2-W is distributed in tape and reel carriers. The tape and reel carriers used to distribute BGS2-E/BGS2-W are packed as described below, including the following required shipping materials:

- Moisture barrier bag, including desiccant and humidity indicator card
- Transportation box

### 6.3.2.1 Moisture Barrier Bag

The tape reels are stored inside an MBB (=moisture barrier bag), together with a humidity indicator card and desiccant pouches - see [Figure 51](#). The bag is ESD protected and delimits moisture transmission. It is vacuum-sealed and should be handled carefully to avoid puncturing or tearing. The bag protects the BGS2-E/BGS2-W modules from moisture exposure. It should not be opened until the devices are ready to be soldered onto the application.

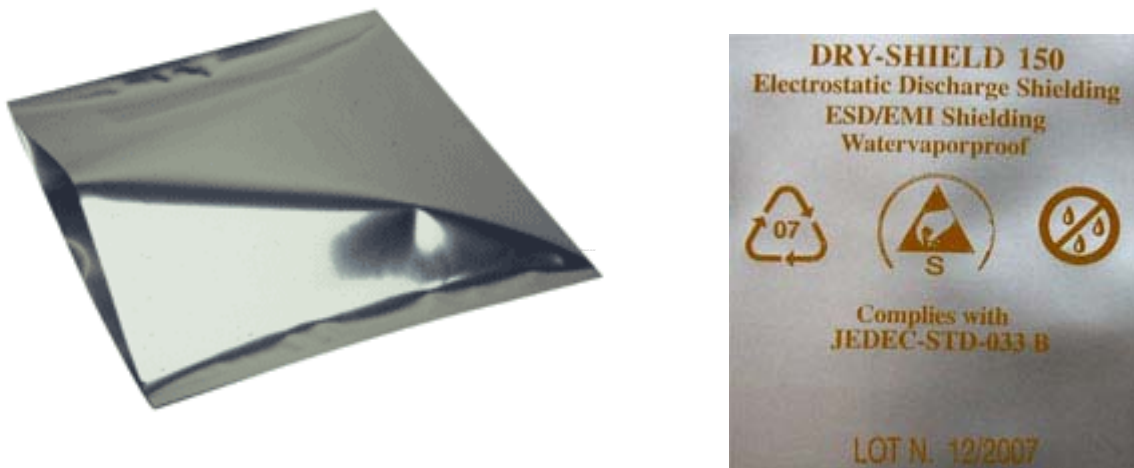



Figure 51: Moisture barrier bag (MBB) with imprint

The label shown in [Figure 52](#) summarizes requirements regarding moisture sensitivity, including shelf life and baking requirements. It is attached to the outside of the moisture barrier bag.



**CAUTION**  
This bag contains  
**MOISTURE-SENSITIVE DEVICES**

LEVEL

4

If blank, see adjacent  
bar code label

1. Calculated shelf life in sealed bag: months at < 40 °C and < 90% relative humidity (RH)
2. Peak package body temperature: 245 °C  
If blank, see adjacent bar code label
3. After bag is opened, devices that will be subjected to reflow solder or other high temperature process must
  - a) Mounted within: 72 hours of factory  
If blank, see adjacent bar code label  
conditions < 30 °C/80%
  - b) stored at < 10% RH
4. Devices require bake, before mounting, if:
  - a) Humidity Indicator Card is > 10% when read at 23 ± 5 °C
  - b) 3a or 3b not met
5. If baking is required, device may be baked for 48 hours at 125 ± 5 °C

Note: If device containers cannot be subjected to high temperature or shorter bake times are desired, reference IPC/JEDEC J-STD-033 for bake procedure

Bag Seal Date: 01.01.2011  
If blank, see adjacent bar code label

Note: Level and body temperature defined by IPC/JEDEC J-STD-020

# CINTERION

**INFO2 DEVICE PART NUMBER**

Peak package body temperature: 245°C Qty.: 500

Mounted within: 72 hours of factory

Bag Seal Date (MMDDYY) : 0 1 0 1 2 0 1 1



Package ID: WM8 0 0 0 1 2 3 4 1 2

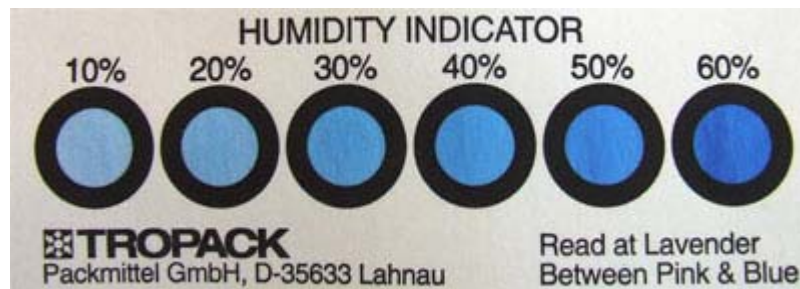

Figure 52: Moisture Sensitivity Label

MBBs contain one or more desiccant pouches to absorb moisture that may be in the bag. The humidity indicator card described below should be used to determine whether the enclosed components have absorbed an excessive amount of moisture.

The desiccant pouches should not be baked or reused once removed from the MBB.

The humidity indicator card is a moisture indicator and is included in the MBB to show the approximate relative humidity level within the bag. Sample humidity cards are shown in [Figure 53](#). If the components have been exposed to moisture above the recommended limits, the units will have to be rebaked.



**Figure 53:** Humidity Indicator Card - HIC

A baking is required if the humidity indicator inside the bag indicates 10% RH or more.

### 6.3.2.2 Transportation Box

Tape and reel carriers are distributed in a box, marked with a barcode label for identification purposes. A box contains two reels with 500 modules each.



### 6.3.3 Trays

If small module quantities are required, e.g., for test and evaluation purposes, BGS2-E/BGS2-W may be distributed in trays. The small quantity trays are an alternative to the single-feed tape carriers normally used. However, the trays are not designed for machine processing. They contain modules to be (hand) soldered onto an external application (for information on hand soldering see [3]).

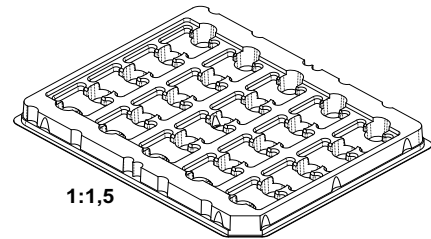

Figure 54: Small quantity tray

Trays are packed and shipped in the same way as tape carriers, including a moisture barrier bag with desiccant and humidity indicator card as well as a transportation box (see also Section 6.3.2).



Figure 55: Tray to ship odd module amounts



Figure 56: Trays with packaging materials



## 7 Sample Application

[Figure 57](#) shows a typical example of how to integrate a BGS2-E/BGS2-W module with an application. Usage of the various host interfaces depends on the desired features of the application.

The audio interface demonstrates the balanced connection of microphone and earpiece. This solution is particularly well suited for internal transducers.

Because of the very low power consumption design, current flowing from any other source into the module circuit must be avoided, for example reverse current from high state external control lines. Therefore, the controlling application must be designed to prevent reverse current flow. Otherwise there is the risk of undefined states of the module during startup and shutdown or even of damaging the module.

Because of the high RF field density inside the module, it cannot be guaranteed that no self interference might occur, depending on frequency and the applications grounding concept. excluded that in some applications dependant on the grounding concept of the customer. The potential interferers may be minimized by placing small capacitors (47pF) at suspected lines (e.g. RXD0, RXT0, VDDL, and ON).

**While developing SMT applications it is strongly recommended to provide test points for certain signals resp. lines to and from the module - for debug and/or test purposes. The SMT application should allow for an easy access to these signals. For details on how to implement test points see [\[3\]](#).**

The EMC measures are best practice recommendations. In fact, an adequate EMC strategy for an individual application is very much determined by the overall layout and, especially, the position of components. For example, mounting the internal acoustic transducers directly on the PCB eliminates the need to use the ferrite beads shown in the sample schematic.

Please note that BGS2-E/BGS2-W is not intended for use with cables longer than 3m.

### Disclaimer

No warranty, either stated or implied, is provided on the sample schematic diagram shown in [Figure 57](#) and the information detailed in this section. As functionality and compliance with national regulations depend to a great amount on the used electronic components and the individual application layout manufacturers are required to ensure adequate design and operating safeguards for their products using BGS2-E/BGS2-W modules.

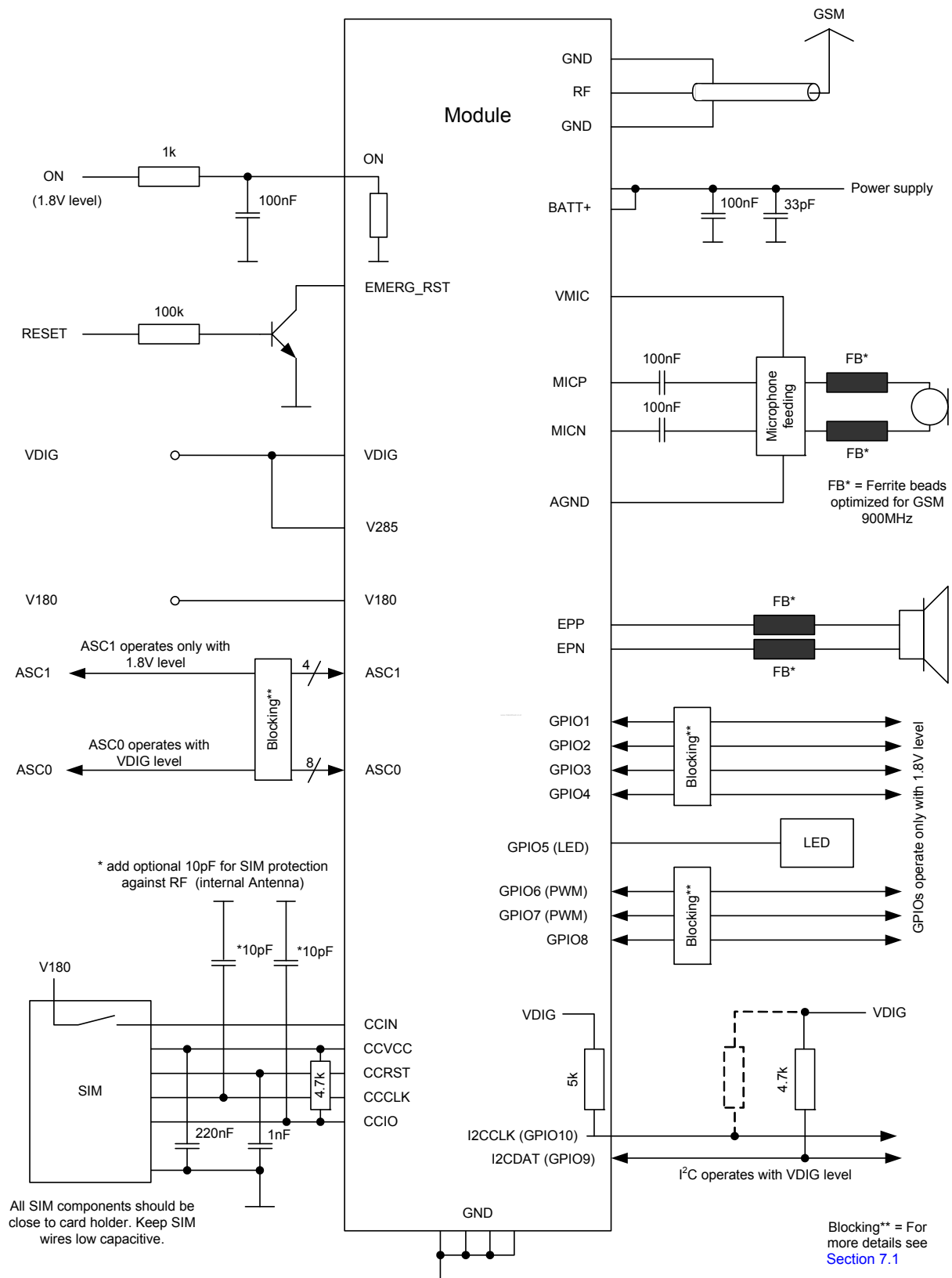

**Figure 57:** Schematic diagram of BGS2-E/BGS2-W sample application

## 7.1 Blocking against RF on Interface Lines

To reduce EMI issues there are serial resistors, or capacitors to GND, implemented on the module for the ignition, emergency restart, and SIM interface lines (cp. Section 5.8). However, all other signal lines have no EMI measures on the module and there are no blocking measures at the module's interface to an external application.

Dependent on the specific application design, it might be useful to implement further EMI measures on some signal lines at the interface between module and application. These measures are described below.

There are five possible variants of EMI measures (A-E) that may be implemented between module and external application depending on the signal line (see Figure 58 and Table 34). Pay attention not to exceed the maximum input voltages and prevent voltage overshots if using inductive EMC measures.

The maximum value of the serial resistor should be lower than 1kOhm on the signal line. The maximum value of the capacitor should be lower than 50pF on the signal line. Please observe the electrical specification of the module interface and the application interface.

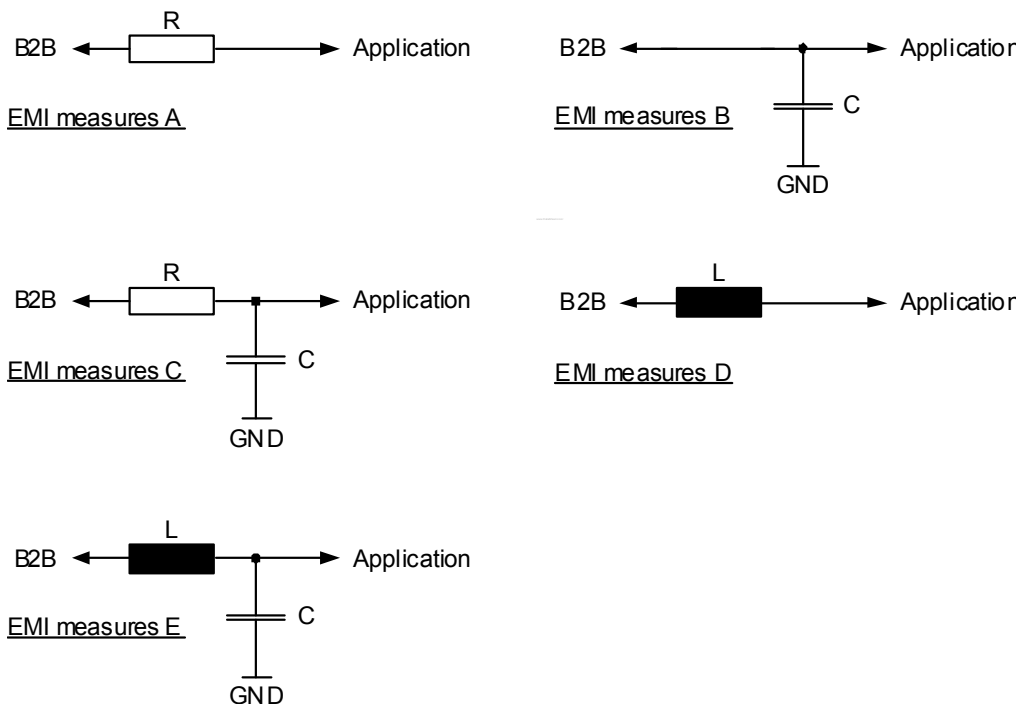

Figure 58: EMI circuits

The following table lists for each signal line at the SMT application interface the EMI measures that may be implemented.

**Table 34:** EMI measures on the application interface

Signal name	EMI measures					Remark
	A	B	C	D	E	
CCIN	x			x		
CCRST		x				The external capacitor should be not higher than 30pF. The value of the capacitor depends on the external application.
CCIO		x				
CCCLK		x				
RXD0	x	x	x	x	x	
TXD0	x	x	x	x	x	
CTS0	x	x	x	x	x	
RTS0				x		
RING0				x		
DTR0	x	x	x	x	x	
DCD0	x	x	x	x	x	
DSR0	x	x	x	x	x	
RXD1	x	x	x	x	x	
TXD1	x	x	x	x	x	
CTS1	x	x	x	x	x	
RTS1	x	x	x	x	x	
GPIO1	x	x	x	x	x	
GPIO2	x	x	x	x	x	
GPIO3	x	x	x	x	x	
GPIO4	x	x	x	x	x	
GPIO5/Status	x	x	x	x	x	
GPIO6/PWM2	x	x	x	x	x	
GPIO7/PWM1	x	x	x	x	x	
GPIO8	x	x	x	x	x	
GPIO9/I2CDAT		x		x		The rising signal edge is reduced with an additional capacitor.
GPIO10/I2CCLK		x		x		
V180		x		x	x	
V285		x		x	x	
VDIG		x		x	x	

## 8 Reference Approval

### 8.1 Reference Equipment for Type Approval

The Cinterion Wireless Modules reference setup submitted to type approve BGS2-E/BGS2-W is shown in the following figure:

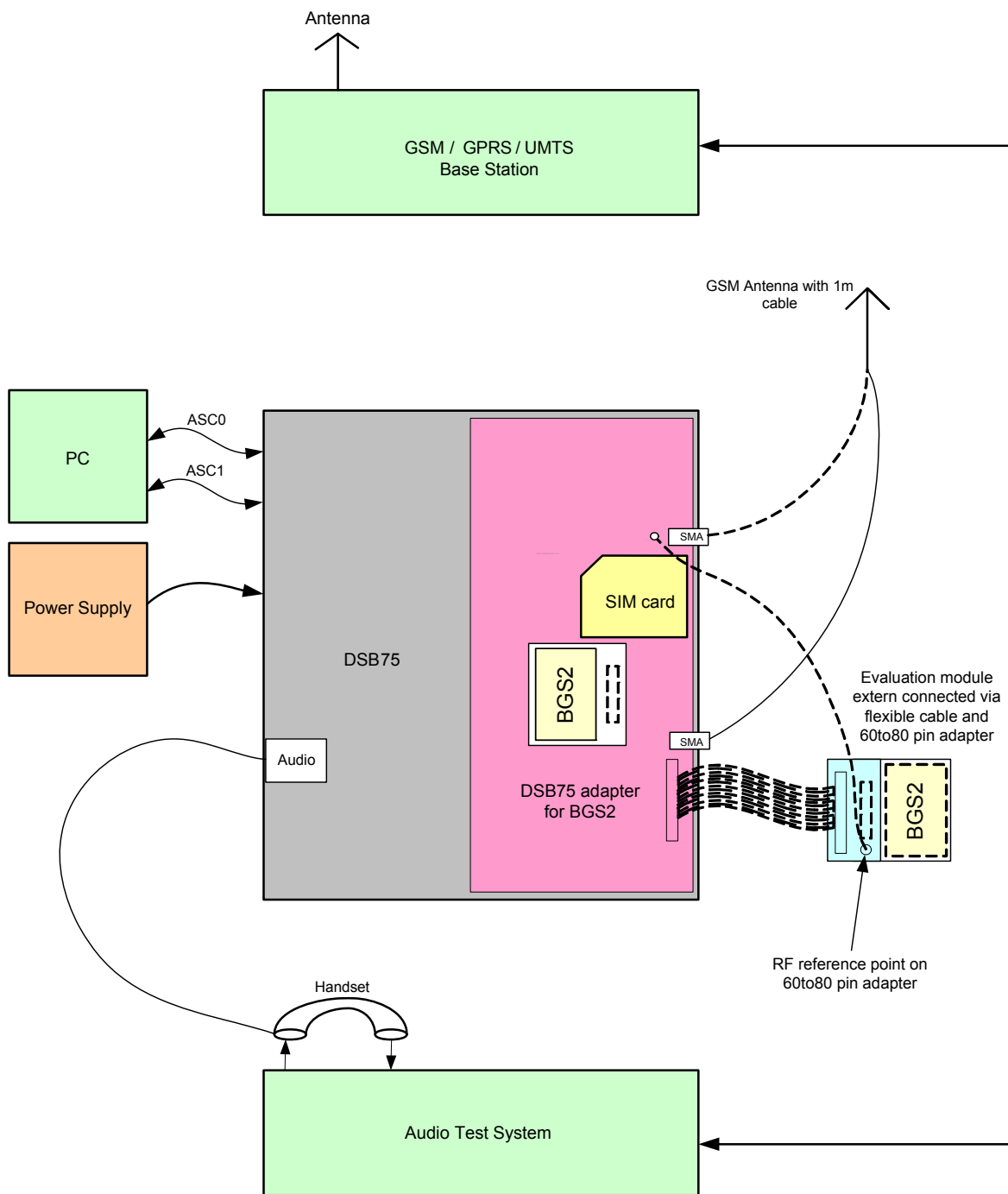

Figure 59: Reference equipment for Type Approval

## 8.2 Compliance with FCC and IC Rules and Regulations

The Equipment Authorization Certification for the Cinterion Wireless Modules reference application described in [Section 8.1](#) will be registered under the following identifiers<sup>1</sup>:

*FCC Identifier: QIPBGS2*

*Industry Canada Certification Number: 7830A-BGS2*

*Granted to Cinterion Wireless Modules GmbH*

Manufacturers of mobile or fixed devices incorporating BGS2-W modules are authorized to use the FCC Grants and Industry Canada Certificates of the BGS2-W modules for their own final products according to the conditions referenced in these documents. In this case, an FCC/ IC label of the module shall be visible from the outside, or the host device shall bear a second label stating "Contains FCC ID QIPBGS2", and accordingly "Contains IC 7830A-BGS2".

### IMPORTANT:

Manufacturers of portable applications incorporating BGS2-W modules are required to have their final product certified and apply for their own FCC Grant and Industry Canada Certificate related to the specific portable mobile. This is mandatory to meet the SAR requirements for portable mobiles (see [Section 1.3.2](#) for detail).

Changes or modifications not expressly approved by the party responsible for compliance could void the user's authority to operate the equipment.

---

1. Applies only for the quad band module variant BGS2-W.

## 9 Appendix

### 9.1 List of Parts and Accessories

**Table 35:** List of parts and accessories

Description	Supplier	Ordering information
BGS2-E/BGS2-W	Cinterion	Standard module Cinterion Wireless Modules IMEI: Ordering number: L30960-N2200-A100 (BGS2-E) Ordering number: L30960-N2210-A100 (BGS2-W)  Customer IMEI mode: Ordering number: L30960-N2205-A100 (BGS2-E) Ordering number: L30960-N2215-A100 (BGS2-W)
DSB75 Evaluation Kit	Cinterion	Ordering number: L36880-N8811-A100
DSB75 adapter for mounting BGS2-E/BGS2-W evaluation modules	Cinterion	Ordering number: L30960-N1801-A100
Evaluation Module	Cinterion	Ordering number: L30960-N2201-A100 (BGS2-E) Ordering number: L30960-N2211-A100 (BGS2-W)
Votronic Handset	VOTRONIC	Votronic HH-SI-30.3/V1.1/0 VOTRONIC Entwicklungs- und Produktionsgesellschaft für elektronische Geräte mbH Saarbrücker Str. 8 66386 St. Ingbert Germany Phone: +49-(0)6 89 4 / 92 55-0 Fax: +49-(0)6 89 4 / 92 55-88 Email: <a href="mailto:contact@votronic.com">contact@votronic.com</a>
SIM card holder incl. push button ejector and slide-in tray	Molex	Ordering numbers: 91228 91236 Sales contacts are listed in <a href="#">Table 36</a> .

**Table 36:** Molex sales contacts (subject to change)

<p>Molex For further information please click: <a href="http://www.molex.com">http://www.molex.com</a></p>	<p>Molex Deutschland GmbH Felix-Wankel-Str. 11 4078 Heilbronn-Biberach Germany  Phone: +49-7066-9555 0 Fax: +49-7066-9555 29 Email: <a href="mailto:mxgermany@molex.com">mxgermany@molex.com</a></p>	<p>American Headquarters Lisle, Illinois 60532 U.S.A.  Phone: +1-800-78MOLEX Fax: +1-630-969-1352</p>
<p>Molex China Distributors Beijing, Room 1319, Tower B, COFCO Plaza No. 8, Jian Guo Men Nei Street, 100005 Beijing P.R. China  Phone: +86-10-6526-9628 Phone: +86-10-6526-9728 Phone: +86-10-6526-9731 Fax: +86-10-6526-9730</p>	<p>Molex Singapore Pte. Ltd. Jurong, Singapore Phone: +65-268-6868 Fax: +65-265-6044</p>	<p>Molex Japan Co. Ltd. Yamato, Kanagawa, Japan  Phone: +81-462-65-2324 Fax: +81-462-65-2366</p>