SPECIFICATION

Revision: 0.1

BH1400T397G

This module uses ROHS material

CUSTOMER:

Approved by:

B&H KOREA CO., LTD.

Approved by:

Revision Record

Rev No	date	Description
V0.1	2013-03-06	Preliminary Specification Release

CONTENTS

- 1.General Description
- 2.Genreal Features
3. Block Diagram
- 4.Pin Description
- 5.Absolute Maximum Ratings
6. Electrical Specification
 - 6.1 DC Characteristics
 - 6.2 back blight circuit characteristics
7. Optical Specification
 - 7.1 LCD optical Characteristics
 - 7.2 Measurement system
- 8.Application Circuit
- 9.Initial Code
10. Reliability and inspection standard
 - 10.1 Environment test(reliability test)
 - 10.2 Ultraviolet radiation irradiation test
 - 10.3 Mechanical test
 - 10.4 Electron magnetic compatibility
11. Inspection standard
- 12.Caution and handing precaution
- 13.Installation in assembly
 - 13.1 ESD(electro-static discharge) prevention
 - 13.2 Dust and stain prevention
 - 13.3 Installing lcd module to the enclosure
 - 13.4 Mechanical forces
 - 13.5 Operation
- 14 .Transportation and storage
- 15.Outline dimension

Written by	Checked by	Approved by
James	James	Roy

1. General Description

The BH1400T397G model is a color TFT LCM th is module has a 3.97 inch diagonally measured active area with WVGA(480 horizontal by 800 vertical pixel array).each pixel is divided into red,green,blue dots which are arranged in vertical stripe and this module can display 262K colors.

2.General Feature

Item	Main Display	Remark
Display Mode	Normally Black, Transmissive LCD	
Viewing direction	Free	
Driving method	a-si TFT active matrix	
Input signals	8/16/24BIT CPU & RGB interface	
Outside dimensions	57.06mm(W) × 98.1mm(H) × 3.3mm(D)	
Active Atea	51.84mm(W) × 86.40mm(H)	
Number of Pixels	480x(RGB) × 800 pixels	
Pixel Pitch	0.108mm(W) × 0. 108mm(H)	
Pixel Arrangment	RGB vertical stripes	
Driver IC	NT35510	
Weight	TBD	

3. Block Diagram

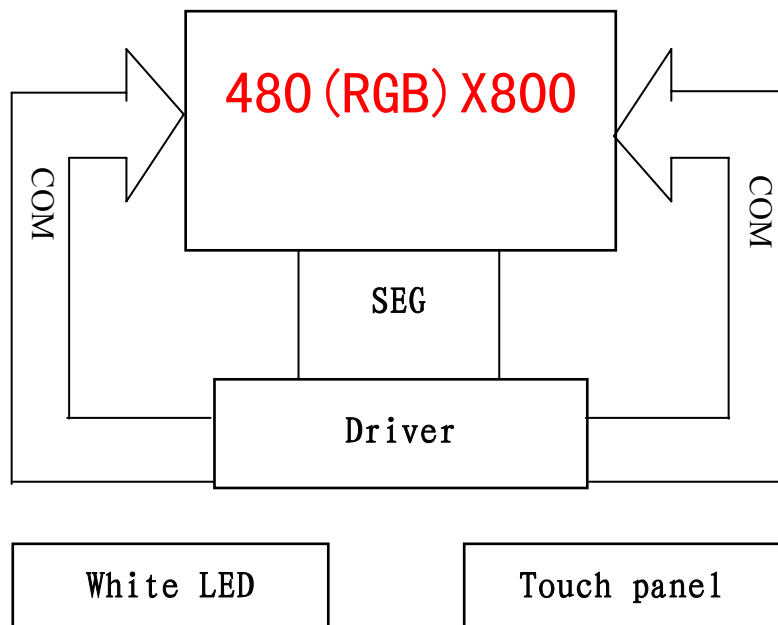

4.Pin Description

No.	Symbol	Description
1	GND	Ground
2	YU	Touch panel coordinate in the up side of envisage drawing
3	XL	Touch panel coordinate in the left side of envisage drawing
4	YD	Touch panel coordinate in the down side of envisage drawing
5	XR	Touch panel coordinate in the right side of envisage drawing
6	VCC	Power supply,2.8V(TYP)
7	VCC	Power supply,2.8V(TYP)
8	GND	Ground
9	VS	Vertical sync. Signal in RGB I/F.
10	HS	Horizontal sync. Signal in RGB I/F.
11	PCLK	Pixel clock signal in RGB I/F.
12	DE	Data enable signal in RGB I/F
13~36	DB0~DB23	Data bus
37	IOVCC	Power supply for IO system,2.8V/1.8V(TYP)
38	GND	Ground
39	RESET	Reset signal, active low
40	CS	Chip select signal
41	RD	Read signal
42	WR/SCL	Write signal/ A synchronous clock signal in SPI I/F.
43	RS	Command/data select signal
44	SDI	Serial input signal in SPI I/F.
45	SDO	Serial output signal in SPI I/F.
46	FMARK	The FMARK signal is used when writing RAM data in synchronization with frame.
47	IM0	IM0=0,IM1=0 CPU8BIT (DB0~7) IM0=0,IM1=1 CPU24BIT (DB0~23)
48	IM1	IM0=1,IM1=0 CPU16BIT (DB0~15) IM0=1,IM1=1 RGB (DB0~23)
49	A	Backlight anode
50	K	Backlight cathode
51	GND	Ground

5. Absolute Maximum Ratings

$T_a=25\pm 5^{\circ}\text{C}, V_{SS}=\text{GND}=0$

Item	Symbol	Ratings	Unit	Condition
Operating power	V_{DD}	$-0.3\sim 4.6$	V	
Operating temperature	T_{OPR}	$-20\sim 70$	°C	No condensation
Storage temperature	T_{STR}	$-30\sim 80$		

6. Electrical Specification

6.1 DC Characteristics

$V_{SS}=0\text{V}, V_{DD}=2.85\pm 0.05\text{V}, T_{OPR}=-20\sim 70^{\circ}\text{C}$

Item	Symbol	Condition	Min.	Typ.	Max.	Unit
Supply power	V_{DD}		2.6	2.8	3.0	V
Input high voltage	V_{IH}		$0.8V_{DD}$	—	V_{DD}	
Input low voltage	V_{IL}		0	—	$0.2V_{DD}$	
Output high voltage	V_{OH}		$0.8V_{DD}$	—	—	
Output low voltage	V_{OL}		—	—	$0.2V_{DD}$	
Logic current consumption	I_{DD}		—			mA
Current consumption during standby mode	I_S		—		—	uA

6.2 Backlight Circuit Characteristics(8 LEDs Serial connection):

Item	Symbol	Min	Typ.	Max.	Unit	Condition
Operating voltage	V_{LED}	24	25.6	27.2	V	$I_{LED}=20\text{ mA}$
Operating current	I_{LED}	—	20	—	mA	-
Back blight luminance (display white)		5000	5600	—	cd/m ²	$I_{LED}=20\text{mA}$

7. Optical Specification

Optical characteristics are determined after the unit has been on and stable for approximately 30 minutes in a dark environment at 25°C. The values specified are at an approximate distance of 500mm from the LCD surface at a viewing angle θ equal to 0.

7.1 LCD Optical Characteristics

Ta=25°C

parameter		Symbol	Condition	Min	Typ	Max	Unit
Viewing Angle	$\Phi = 90^\circ$	θ	Cr > 10	-	80	-	deg
	$\Phi = 270^\circ$			-	80	-	
	$\Phi = 0^\circ$			-	80	-	
	$\Phi = 180^\circ$			-	80	-	
Contrast ratio		Cr	$\theta=0$	350	500	-	
Response time		Tr+Tf	$\Phi=0$	-	25	-	ms
Surface Luminance		Lv		-	450	-	Cd/m ²
CIE(x,y) chromaticity	RED	X	$\theta=0$ $\Phi=0$	0.630	0.650	0.670	
		Y		0.312	0.332	0.352	
	GREEN	X		0.297	0.317	0.337	
		Y		0.555	0.575	0.595	
	BLUE	X		0.119	0.139	0.159	
		Y		0.112	0.132	0.152	
	WHITE	X		0.289	0.309	0.329	
		Y		0.322	0.342	0.362	

7.2 Measurement system

(1) LCD Viewing Angle

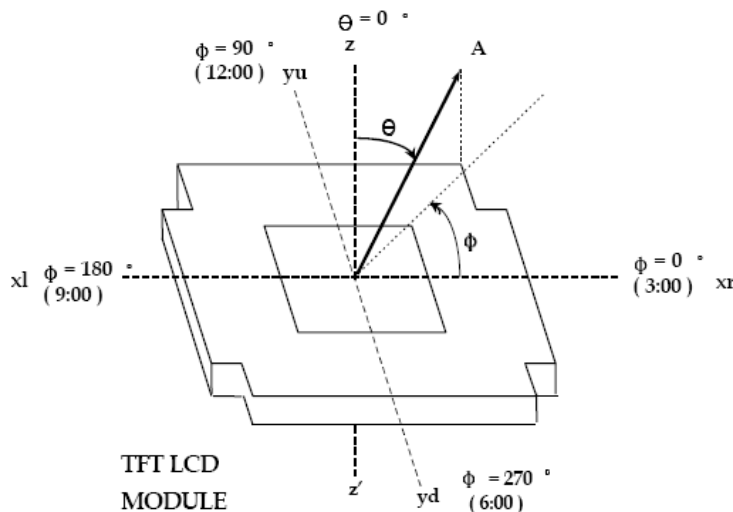

viewing angle is the angle at which the contrast ratio is greater than 10. The angles are determined for the horizontal or x axis and the vertical or y axis with respect to the z axis which is normal to the LCD surface.

(2) Response time

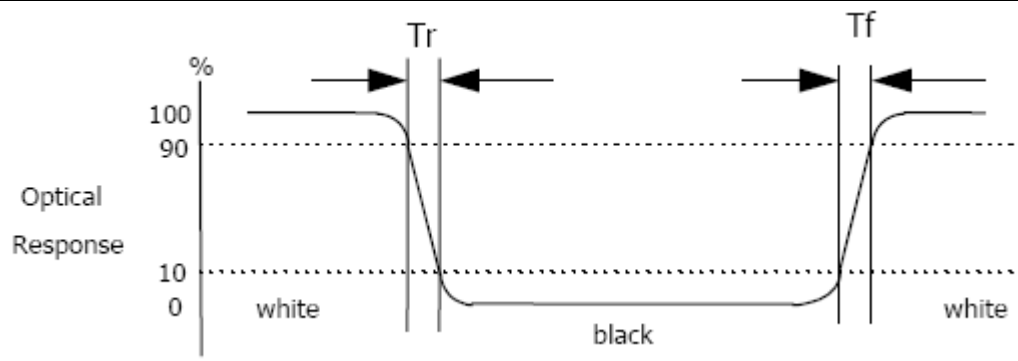

Response time is the time required for the display to transition from white to black (Rising time, Tr) and from black to white (Falling time, Tf).for additional information

(3) Contrast Ratio(CR)

Contrast Ratio(CR) is defined mathematically as:

$$\text{Contrast Ratio} = \frac{\text{Surface Luminance with all white pixels}}{\text{Surface Luminance with all black pixels}}$$

Surface luminance is the center point across the lcd surface 500mm from the surface with all pixels displaying white.

8. Application Circuit

Please consult our technical department for detail information.

9. Initial Code

Please consult our technical department for detail information.

10. Reliability and inspection standard

10.1 Environment test(reliability test)

Samples OK before testing

Test item	Test condition
High temperature storage	80°C , 240 hr
Low temperature storage	-30°C , 240 hr
High temperature operation	70°C , 160 hr
Low temperature operation	-20°C , 160 hr
High temperature and high humidity operation	40°C , 93 %RH, 160 hr
Thermal shock	-30°C → 25°C → 80°C → 25°C (30min) (5min) (30min) (5min) 20 cycle

After completing the reliability tests.leave the samples under the room temperature and for the following inspection items:

- ① No clearly visible defects or deterioration of display quality allowed.
- ② No function-related abnormalities.
- ③ Connected parts still connecting tightly.
- ④ Display characteristics fulfil initial value, contrast ratio should be an least 30% of initial value.

10.2 Ultraviolet radiation irradiation test

After Samples irradiated by ultraviolet tradiation,have no deterioration of display quality

10.3 Mechanical test

1)Vibration test

Test item	Test content	
In mobile telephone	Reference mobile phone test standard	
Vibration test (packed)	frequence/acceleration	30Hz/2.5m/s ²
	direction	X、 Y、 Z 3 direction
	time	30min respectively

After completing the vibration tests,the samples have No function-related abnormalities or structure distortion .

2) Shock test

Peak acceleration m/s ²	Pulseholding time ms	Shock wave
300	11	Half sine wave or back peak sawtooth wave or trapeziform wave

After completing the shock tests,the samples have No function-related abnormalities or structure distortion .

3)packing part drop test

Test item	Test content	
drop (packed in a box)	height	80cm
	Drop mode	Freedom drop
	Drop part	1 corner/3 arris/6 face,1time respectively

After completing the packing part drop tests,the samples have no function-related abnormalities or structure distortion .

10.4 Electron magnetic compatibility

Electrostatic withstanding voltage

After air contact discharge (voltage: $\pm 8KV$) and contact discharge directly (voltage: $\pm 4KV$) test, the samples display ok ,and have no flicker、white screen、black screen、blue screen etc.abnormity display.。

11. Inspection standard

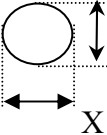
No	Item	Criterion for defects	Defect type																																														
1	Black/white spot defect (in displaying)	<p>black/white spot definition</p> $\Phi = \frac{(x+y)}{2}$  <p>1. black/white spot defect (I)</p> <table border="1"> <thead> <tr> <th rowspan="2">area size (mm)</th> <th colspan="3">Acceptable number</th> </tr> <tr> <th>A</th> <th>B</th> <th>C</th> </tr> </thead> <tbody> <tr> <td>$\Phi \leq 0.1$</td> <td colspan="3">ignore</td> </tr> <tr> <td>$0.10 < \Phi \leq 0.15$</td> <td colspan="3">3</td> </tr> <tr> <td>$0.15 < \Phi \leq 0.25$</td> <td colspan="3">2</td> </tr> <tr> <td>$\Phi > 0.25$</td> <td colspan="3">0</td> </tr> </tbody> </table> <p>2. black/white spot defect (II)</p> <table border="1"> <thead> <tr> <th rowspan="2">area size (mm)</th> <th colspan="3">Acceptable number</th> </tr> <tr> <th>A</th> <th>B</th> <th>C</th> </tr> </thead> <tbody> <tr> <td>$\Phi \leq 0.3$</td> <td colspan="3">ignore</td> </tr> <tr> <td>$0.30 < \Phi \leq 0.50$</td> <td colspan="3">5 (space between is 20mm)</td> </tr> <tr> <td>$0.50 < \Phi \leq 1.00$</td> <td colspan="3">3 (space between is 50mm)</td> </tr> <tr> <td>$1.00 < \Phi$</td> <td colspan="3">0</td> </tr> </tbody> </table>	area size (mm)	Acceptable number			A	B	C	$\Phi \leq 0.1$	ignore			$0.10 < \Phi \leq 0.15$	3			$0.15 < \Phi \leq 0.25$	2			$\Phi > 0.25$	0			area size (mm)	Acceptable number			A	B	C	$\Phi \leq 0.3$	ignore			$0.30 < \Phi \leq 0.50$	5 (space between is 20mm)			$0.50 < \Phi \leq 1.00$	3 (space between is 50mm)			$1.00 < \Phi$	0			Minor
area size (mm)	Acceptable number																																																
	A	B	C																																														
$\Phi \leq 0.1$	ignore																																																
$0.10 < \Phi \leq 0.15$	3																																																
$0.15 < \Phi \leq 0.25$	2																																																
$\Phi > 0.25$	0																																																
area size (mm)	Acceptable number																																																
	A	B	C																																														
$\Phi \leq 0.3$	ignore																																																
$0.30 < \Phi \leq 0.50$	5 (space between is 20mm)																																																
$0.50 < \Phi \leq 1.00$	3 (space between is 50mm)																																																
$1.00 < \Phi$	0																																																
2	Black/white line defect (in displaying)	<p>1. black/white line defect (I)</p> <table border="1"> <thead> <tr> <th colspan="2">size (mm)</th> <th colspan="3">Acceptable number</th> </tr> <tr> <th rowspan="2">L(length)</th> <th rowspan="2">W(width)</th> <th colspan="3">area</th> </tr> <tr> <th>A</th> <th>B</th> <th>C</th> </tr> </thead> <tbody> <tr> <td>$10 < L$</td> <td>$0.03 < W \leq 0.04$</td> <td colspan="3">5</td> </tr> <tr> <td>$5.0 < L \leq 10$</td> <td>$0.04 < W \leq 0.06$</td> <td colspan="3">3</td> </tr> <tr> <td>$1.0 < L \leq 5.0$</td> <td>$0.06 < W \leq 0.07$</td> <td colspan="3">2</td> </tr> <tr> <td>$L \leq 1.0$</td> <td>$0.07 < W \leq 0.09$</td> <td colspan="3">1</td> </tr> </tbody> </table> <p>2. black/white line defect (II)</p>	size (mm)		Acceptable number			L(length)	W(width)	area			A	B	C	$10 < L$	$0.03 < W \leq 0.04$	5			$5.0 < L \leq 10$	$0.04 < W \leq 0.06$	3			$1.0 < L \leq 5.0$	$0.06 < W \leq 0.07$	2			$L \leq 1.0$	$0.07 < W \leq 0.09$	1			Minor													
size (mm)		Acceptable number																																															
L(length)	W(width)	area																																															
		A	B	C																																													
$10 < L$	$0.03 < W \leq 0.04$	5																																															
$5.0 < L \leq 10$	$0.04 < W \leq 0.06$	3																																															
$1.0 < L \leq 5.0$	$0.06 < W \leq 0.07$	2																																															
$L \leq 1.0$	$0.07 < W \leq 0.09$	1																																															

		<table border="1"> <thead> <tr> <th colspan="2">size(mm)</th> <th colspan="3">Acceptable</th> </tr> <tr> <th rowspan="2">L(length)</th> <th rowspan="2">W(width)</th> <th colspan="3">area</th> </tr> <tr> <th>A</th> <th>B</th> <th>C</th> </tr> </thead> <tbody> <tr> <td>$20 < L$</td> <td>$0.05 < W \leq 0.07$</td> <td colspan="2">5</td> <td rowspan="4">ignore</td> </tr> <tr> <td>$10 < L \leq 20$</td> <td>$0.07 < W \leq 0.09$</td> <td colspan="2">3</td> </tr> <tr> <td>$5.0 < L \leq 10$</td> <td>$0.09 < W \leq 0.10$</td> <td colspan="2">2</td> </tr> <tr> <td>$L \leq 5.0$</td> <td>$0.10 < W \leq 0.15$</td> <td colspan="2">1</td> </tr> </tbody> </table>	size(mm)		Acceptable			L(length)	W(width)	area			A	B	C	$20 < L$	$0.05 < W \leq 0.07$	5		ignore	$10 < L \leq 20$	$0.07 < W \leq 0.09$	3		$5.0 < L \leq 10$	$0.09 < W \leq 0.10$	2		$L \leq 5.0$	$0.10 < W \leq 0.15$	1																																													
size(mm)		Acceptable																																																																										
L(length)	W(width)	area																																																																										
		A	B	C																																																																								
$20 < L$	$0.05 < W \leq 0.07$	5		ignore																																																																								
$10 < L \leq 20$	$0.07 < W \leq 0.09$	3																																																																										
$5.0 < L \leq 10$	$0.09 < W \leq 0.10$	2																																																																										
$L \leq 5.0$	$0.10 < W \leq 0.15$	1																																																																										
3	Blemish & foreign matters	<p>1. dot (LCD)</p> <table border="1"> <thead> <tr> <th rowspan="3">size(mm)</th> <th colspan="3">Acceptable number</th> </tr> <tr> <th colspan="3">area</th> </tr> <tr> <th>A</th> <th>B</th> <th>C</th> </tr> </thead> <tbody> <tr> <td>$\Phi \leq 0.1$</td> <td colspan="2">ignore</td> <td rowspan="4">ignore</td> </tr> <tr> <td>$0.10 < \Phi \leq 0.15$</td> <td colspan="2">2</td> </tr> <tr> <td>$0.15 < \Phi \leq 0.25$</td> <td colspan="2">1</td> </tr> <tr> <td>$0.25 < \Phi$</td> <td colspan="2">0</td> </tr> </tbody> </table> <p>2. blemish (on touch panle or between touch panel ane LCD)</p> <table border="1"> <thead> <tr> <th rowspan="3">size(mm)</th> <th colspan="3">Acceptable number</th> </tr> <tr> <th colspan="3">AREA</th> </tr> <tr> <th>A</th> <th>B</th> <th>C</th> </tr> </thead> <tbody> <tr> <td>$\Phi \leq 0.1$</td> <td colspan="2">ignore</td> <td rowspan="3">ignore</td> </tr> <tr> <td>$0.10 < \Phi \leq 0.15$</td> <td colspan="2">1</td> </tr> <tr> <td>$0.15 < \Phi$</td> <td colspan="2">0</td> </tr> </tbody> </table> <p>3.line (LCD/touch panle)</p> <table border="1"> <thead> <tr> <th colspan="2">size(mm)</th> <th colspan="3">Acceptable number</th> </tr> <tr> <th rowspan="2">L(length)</th> <th rowspan="2">W(width)</th> <th colspan="3">area</th> </tr> <tr> <th>A</th> <th>B</th> <th>C</th> </tr> </thead> <tbody> <tr> <td>Ignore</td> <td>$W \leq 0.02$</td> <td colspan="2">5</td> <td rowspan="4">ignore</td> </tr> <tr> <td>$L \leq 3.0$</td> <td>$0.02 < W \leq 0.03$</td> <td colspan="2">3</td> </tr> <tr> <td>$L \leq 2.0$</td> <td>$0.03 < W \leq 0.05$</td> <td colspan="2">2</td> </tr> <tr> <td>---</td> <td>$W > 0.05$</td> <td colspan="2">Treat with</td> </tr> </tbody> </table>	size(mm)	Acceptable number			area			A	B	C	$\Phi \leq 0.1$	ignore		ignore	$0.10 < \Phi \leq 0.15$	2		$0.15 < \Phi \leq 0.25$	1		$0.25 < \Phi$	0		size(mm)	Acceptable number			AREA			A	B	C	$\Phi \leq 0.1$	ignore		ignore	$0.10 < \Phi \leq 0.15$	1		$0.15 < \Phi$	0		size(mm)		Acceptable number			L(length)	W(width)	area			A	B	C	Ignore	$W \leq 0.02$	5		ignore	$L \leq 3.0$	$0.02 < W \leq 0.03$	3		$L \leq 2.0$	$0.03 < W \leq 0.05$	2		---	$W > 0.05$	Treat with		Minor
size(mm)	Acceptable number																																																																											
	area																																																																											
	A	B	C																																																																									
$\Phi \leq 0.1$	ignore		ignore																																																																									
$0.10 < \Phi \leq 0.15$	2																																																																											
$0.15 < \Phi \leq 0.25$	1																																																																											
$0.25 < \Phi$	0																																																																											
size(mm)	Acceptable number																																																																											
	AREA																																																																											
	A	B	C																																																																									
$\Phi \leq 0.1$	ignore		ignore																																																																									
$0.10 < \Phi \leq 0.15$	1																																																																											
$0.15 < \Phi$	0																																																																											
size(mm)		Acceptable number																																																																										
L(length)	W(width)	area																																																																										
		A	B	C																																																																								
Ignore	$W \leq 0.02$	5		ignore																																																																								
$L \leq 3.0$	$0.02 < W \leq 0.03$	3																																																																										
$L \leq 2.0$	$0.03 < W \leq 0.05$	2																																																																										
---	$W > 0.05$	Treat with																																																																										

4	Stain on LCD panel surface	Stain which cannot be removed even when wiped lightly with a soft cloth or similar cleaning too are rejectable	Minor
5	Rust in bezel	Rust which is visible in the bezel is rejectable	Minor
6	Defect of land surface contact	Evident crevices which is visble are rejectable	Minor
7	Parts mounting	(1) failure to mount parts (2) parts not in the specification are mounted (3) polarith, for example, is reversed	Major Major Major
8	Parts alignment	(1) LSI,IC lead width is more than 50% beyond pad outline (2) Chip component is off center and more than 50% of the leads is off the pad outline	Minor Minor
9	Conductive foreign matter	(1) on open space(gnd,manual solder)solder ball is allowed up to Φ 0.1mm(1EA). (2) In case of shield space is allowed up to Φ 0.2mm(1EA)	Major
10	Faculty PWB correction	(1) due to PWB copper foil pattern burnout,the patter is connected,using a jumper wire for repair;2 or more places corrected per PWB (2) short circuited part is cut,and no resist coating has been performed.	Minor Minor

area definition

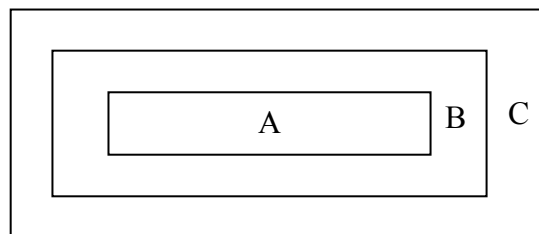

LCD inspection area

A: active area

B: visible area

C: outside of visible area (Invisible area after assembling)

Visible Defect in area c, but it cannot affect product's quality, it is allowed.

12. Caution and handling precaution

To avoid causing extended damages such as accidents resulting in injury or death, fire accidents, or social damages or social damages if the lcd module fails, Sunrise is always endeavor to maintain sufficient quality of the lcd module in process of designing and manufacturing.

Please pay attention to the followings when you use this TFT LCD module.
Safety

1) **disassembling or modification**

do not disassemble or modify the modules. sensitive parts inside lcd module may be damaged, and dusts or scratches may mar the displays.

2) **Breakage of lcd panel**

Do not ingest liquid crystal material, do not inhale this material, and do not permit this material to contact the skin, if glass of lcd panel is broken. if liquid crystal material contacts the skin, mouth or clothing, take the following actions immediately.

In case contact to the eye or mouth, rinse with large amount of running water for more than 15 minutes. in case contact to the skin or clothing, wipe it off immediately and wash with soap and large amount of running water for more than 15 minutes. the skin or clothing may be damaged if liquid crystal material is left adhered. in case ingestion, rinse out the mouth well with water. after spewing up by drinking large amount of water, get medical treatment.

3) **Glass of lcd panel**

be careful with chips of glass that may cause injuring fingers or skin, when the glass is broken.

4) **Absolute maximum ratings**

Do not exceed the absolute maximum rating value under the worst probable condition caused by the supply voltage variation, input voltage variation, variation in parts' constants, environmental temperature, etc., otherwise lcd module may be damaged.

5) **power protection circuit**

employ protection circuit for power supply, whenever the specification specifies it.

A suitable protection circuit should be applied, based on each system design.

A fuse is not fitted to this module. therefore, without a suitable power-supply protection device, dust or partial circuit failure may cause overheating and/or burning, which may lead to injury.

6) **Disposal**

Always comply with all applicable environmental regulations, when disposing of the lcd.

7) **Edges of parts**

Be careful with edges of glass parts and metal frame, it may cause injuring.

For designing the system, give special consideration that the wiring and parts do not touch those edges.

8) **Recommended operating conditions**

Don't exceed the recommended operation conditions in this specification. the performance and quality of the lcd module are warranted only when the lcd module is used within the recommended operation conditions. to use the lcd module over the recommended operation condition may have bad influence on the characteristics and reliability of the lcd module and may shorten the life of the lcd module.

Therefore, when designing the whole set, not to be over the recommended operation conditions, you should fully take care of supply voltage change, characteristics of connection parts, surge of

input-and-output line,and surrounding temperature.

13.Installation in assembly

13.1 ESD(electro-static discharge) prevention

The circuit used in lcd module is very sensitive to ESD. The following caution should be taken when installing lcd module to an enclosure of the system in order to prevent damage of circuit used in lcd module.

1) Humidity

Ambient humidity of working area is recommended to be higher than 50%(RH) in order to avoid ESD.

2) Grounding

-Person handling lcd modules should be grounded with wrist band.

-Tools like soldering iron and screw drivers and working benches should be grounded.

-Grounded electro-conductive mats are recommended to be covered on the floor of working area and surface of working benches.

-The grounding should be done through a resistor of 0.5-1Mohms in order to prevent spark of ESD.

3) Be careful with touching metal portion of testing instruments in order to prevent unnecessary ESD.

4) Do not touch the electrode area of PCB and electrical parts like LSI,capacitor,connector pin,etc.

5) Ionizer

Using ionizer(an antistatic blower)is recommended at working area in order to reduce electro-static voltage.

6) Removing protection film

When removing protection film from lcd panel,peel off the tag slowly(more than one second)while blowing with ionizer toward the peelong face to minimize ESD which may damage electrical circuit.

13.2. Dust and stain prevention

1) Working area

Reduce dust level in working area.especially the level of metal particle should be decreased,otherwise electrical circuit in lcd module may be damaged due to short circuit by metal particles.

2) Protection film

Lcd module may be shipped with protection film on lcd panle in order to prevent from scratches and dust.it is recommended to remove the film at later process of assembling.

3) Wiping off dust on the panel

When lcd panel becomes dirty,wipe the panle surface off softly with absorbent cotton or another

soft cloth.if necessary,breathe upon the panel surface and then wipe off immediately and softly again.be careful not to spill organic solvents into the inside of lcd module.the solvents may be damaged by the solvents,so do not use any organic solvents for wiping off lcd panel.

4) Adhesive on lcd panel

Be careful not to attach adhesive,grease.etc.,on lcd panel,because it is difficult to remove them without any damages on lcd panel.

5) Water spots on the panel

Avoid the dewing or water condensation.

Wipe off a spot or mist on lcd panel softly with absorbent cotton another cloth as soon as possible if happened,otherwise discoloration or stain may be caused.and ,damage may occur if water penetrates the inside.

13.3.Installing lcd module to the enclosure

1) Installing lcd module to the enclosure

Do not bend or twist lcd module even momentarily when the lcd module is installed into the system.

Bending or twisting the lcd module may cause permanent damage.

When the FPC is bent,the radius of FPC curvature must be more than value of recommendation to prevent bending and twisting forces from affecting the connection of FPC.

Even temporary bending or twisting sometimes causes damage.

2) Interface

Do not fasten screw,with catching interface FPC between lcd module and enclosure.

This may cause bending of lcd module,or become the cause of a failure by damaging FPC.

13.4.Mechanical forces

1) Carry

Hold the side of the plastic frame when you carry an lcd module by hand.if an lcd is carried using the FPC,it is likely to be damaged and the lcd will then malfunction.if you turn on the lcd with a broken FPC,it may cause smoke or burning.

Protection (eg gloves)for fingers and hands is recommended to avoid injury by broken glass.

2) Strong mechanical shock

Avoid strong mechanical shock.such as dropping the lcd from the work bench, or knocking it against a hard object.

3) Excessive force

Avoid applying excessive force,like pushing the surface of lcd panel.this may cause scratches or breakage of the panel,or a failure of the module.

4) Scratches on the panel

Do not put heavy object such as tools,books,etc.,and do not pile up lcd modules.

Be careful not to touch the surface of the polarizer with any hard and sharp object.these parts are so sensitive and can easily be scratched ,even if protected by a film.

5) Connector

When inserting or disconnecting the connector into a connector of the lcd module,care should be

taken to ensure that no strong external force is applied to the connector on the lcd module side. A strong external force applied to the connector or the FPC may damage that no part such as the FPC etc. should be caught between the case of the system and the module. Make sure that the input signal connector of a module is securely and correctly connected to the connector on the system, not skewed, or incompletely connected. Inputting a signal etc. into the module with connectors incorrectly inserted may cause a circuit component or components to malfunction.

6) FPC

When inserting or disconnecting the connector of the lcd module into a connector of the system, care should be taken to ensure that no strong external force is applied to the FPC on the lcd module side. A strong external force applied to the FPC may damage their connections. When assembling a module into a system, pay extra attention to ensure that no part such as the FPC etc. should be caught between the case of the system and the module. Make sure that the input signal connector of a module is securely and correctly connected to the connector on the system, not skewed, or incompletely connected. Inputting a signal etc. into the module with connectors incorrectly inserted may cause a circuit component or components to malfunction. Be careful not to pull or damage the FPC cables, to avoid mechanical damage in FPC and connection part of FPC and cell.

13.5. Operation

1) Power supply

Power supplies should always be turned off during the assembly process. Do not connect or disconnect the power cables and connectors with power applied to lcd module. This may cause damage to the lcd module circuit. In operating module at the inspection process, and so on, the supply voltage and signals of driving device must satisfy the sequence of power supplies and signals described in this specifications.

2) Gas

Do not expose the lcd module to any gas which is not normally contained in the atmosphere, it may cause mis-operation or defects.

3) Used for long term

When a lcd module is used for a long term, the characteristics of lcd module might be changed and it may be out of the standard of optical specifications due to LED discoloration. LED has the characteristics of shifting optical characteristics by the long term use

14 .Transportation and storage

1) temperature

do not store lcd module in a high temperature and high humidity condition,high than 35°C and 70%(RH)for a long term ,meaning about one month or more,otherwise this may deteriorate the quality of the display.when you unavoidably store lcd modules for a long time,store between 0 and 35°C and with a relative humidty 70%or lower.

2) Low temperature

Be careful not to leave it where the temperature is below specified storage temperature because the liquid crystal of the display panel may be damaged.

3) Ultra violet ray

Store lcd module without exposure to direct sunlight or fluorescent lamps in order to prevent the module from strong ultra violet ray.

4) Cleanliness

Keep the lcd module in clean place,because any dust,hard particle may damage the polarizer,or dust invades the inside of the lcd module.

5) Condensation of water

The module should be stored under a condition where no condensation of water is allowed.it may cause mis-operation or defects.be especially careful not to make a module work under the condition that condensation of water appears.

6) Packing

When you must re-package a lcd module after it has been removed from the original packaging,it is recommended to re-pack using the original package box and package material.

