

Version: 0.2 2012-12-24

H2026N700N TFT LCD Module

---

# SPECIFICATION

Revision: 0.2

**B H2026N700N**

This module uses ROHS material

CUSTOMER:

Approved by:

HONGRUI TECHNOLOGY LTD:

Approved by:

Version: 0.2 2012-12-24

H2026N700N TFT LCD Module

---

## Revision Record

Rev No	date	Description
V0.1	2012-12-04	Preliminary Specification Release
V0.2	2012-12-24	Change The Resolution

---

**CONTENTS**

- 1.General Description
- 2.Genreal Features
- 3. Block Diagram
- 4.Pin Description
- 5.Absolute Maximum Ratings
- 6. Electrical Specification
  - 6.1 DC Characteristics
  - 6.2 back blight circuit characteristics
- 7. Optical Specification
  - 7.1 LCD optical Characteristics
  - 7.2 Measurement system
- 8.Application Circuit
- 9.Initial Code
- 10 . Reliability and inspection standard
  - 10.1 Environment test(reliability test)
  - 10.2 Ultraviolet radiation irradiation test
  - 10.3 Mechanical test
  - 10.4 Electron magnetic compatibility
- 11. Inspection standard
- 12.Caution and handing precaution
- 13.Installation in assembly
  - 13.1 ESD(electro-static discharge) prevention
  - 13.2 Dust and stain prevention
  - 13.3 Installing lcd module to the enclosure
  - 13.4 Mechanical forces
  - 13.5 Operation
- 14 .Transportation and storage
- 15.Outline dimension

<b>Written by</b>	<b>Checked by</b>	<b>Approved by</b>
Jack	Robert	Jude

## H2026N700N TFT LCD Module

## 1. General Description

The BH2026N700N model is a color TFT LCM this module has a 7 inch diagonally measured active area with WSVGA(1024 horizontal by 600 vertical pixel array).each pixel is divided into red,green,blue dots which are arranged in vertical stripe and this module can display 262K colors.

## 2.General Feature

Item	Main Display	Remark
Display Mode	Normally white, Transmissive LCD	
Viewing direction	6 o'clock	
Driving method	a-si TFT active matrix	
Outside dimensions	165.75mm(W)×105.39mm(H)×3.4mm(D)	
Active Atea	153.6mm(W)×90mm(H)	
Number of Pixels	1024×(RGB)×600 pixels	
Pixel Pitch	0.05mm(W)×0.15mm(H)	
Pixel Arrangement	RGB vertical stripes	
Weight	TBD	

## 3. Block Diagram

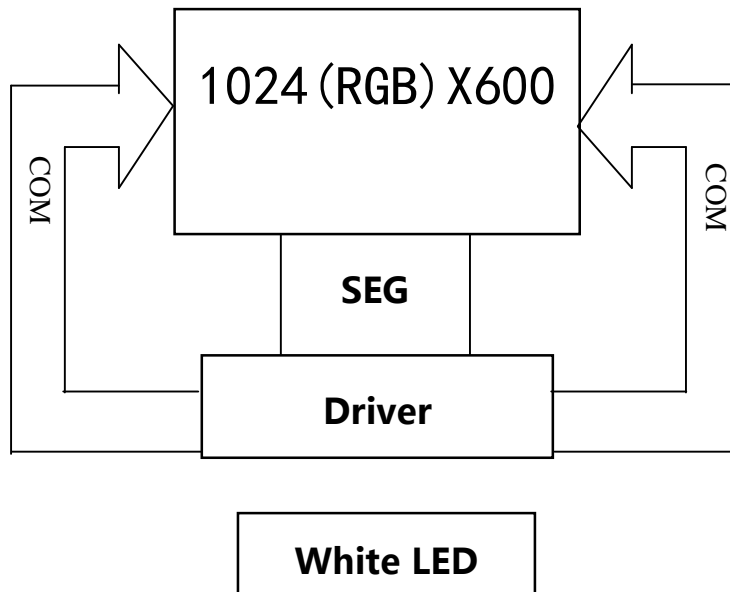

## H2026N700N TFT LCD Module

## 4.Pin Description

No.	Symbol	Description
1	VCOM	Common Voltage
2	VDD	Power Voltage for digital circuit
3	VDD	Power Voltage for digital circuit
4	NC	No connection
5	Reset	Global reset pin
6	STBYB	Standby mode, Normally pulled high STBYB=1, normal operation STBYB=0, timing controller, sourced driver will turn off, all output are High-Z
7	GND	Ground
8	RXIN0-	-LVDS differential data input
9	RXIN0+	+LVDS differential data input
10	GND	Ground
11	RXIN1-	-LVDS differential data input
12	RXIN1+	+LVDS differential data input
13	GND	Ground
14	RXIN2-	-LVDS differential data input
15	RXIN2+	+LVDS differential data input
16	GND	Ground
17	RXCLKIN-	-LVDS differential data input
18	RXCLKIN+	+LVDS differential data input
19	GND	Ground
20	RXIN3-	-LVDS differential data input
21	RXIN3+	+LVDS differential data input
22	GND	Ground
23	NC	No connection
24	NC	No connection
25	GND	Ground
26	NC	No connection
27	DIMO	Backlight CABC controller signal output
28	SELB	6bit/8bit mode select, See Note1
29	AVDD	Power for Analog Circuit
30	GND	Ground
31	LED-	LED Cathode
32	LED-	LED Cathode
33	L/R	Horizontal inversion, See Note3
34	U/D	Vertical inversion, See Note3
35	VGL	Gate OFF Voltage
36	CABCEN1	CABC H/W enable, See Note2
37	CABCEN0	CABC H/W enable, See Note2
38	VGH	Gate ON Voltage
39	LED+	LED Anode
40	LED+	LED Anode

Note 1: If LVDS input data is 6 bits, SELB must be set to High;

If LVDS input data is 8 bits, SELB must be set to Low;

Note 2:

## H2026N700N TFT LCD Module

CABC_EN	
00	CABC OFF
01	user interface image
10	Still picture
11	Moving image

When CABC off, don't connect DIMO, else connect it to backlight;

Note3:

L/R=0	Set right to left scan dirction
L/R=1	Set left to right scan dirction
U/D=0	Set top to bottom scan dirction
U/D=1	Set bottom to top scan dirction

### 5. Absolute Maximum Ratings

$T_a=25\pm 5^{\circ}\text{C}$ ,  $V_{SS}=\text{GND}=0$

Item	Symbol	Ratings	Unit	Condition
Operating power	$V_{DD}$	-0.3~5.0	V	
Operating temperature	$T_{OPR}$	-20~60	°C	No condensation
Storage temperature	$T_{STR}$	-30~70		

### 6. Electrical Specification

#### 6.1 DC Characteristics

$V_{SS}=0\text{V}$ ,  $V_{DD}=2.85\pm 0.05\text{V}$ ,  $T_{OPR}=-20\sim 70^{\circ}\text{C}$

Item	Symbol	Condition	Min.	Typ.	Max.	Unit
Supply power	$V_{DD}$		2.7	3.3	3.6	V
Input high voltage	$V_{IH}$		$0.7V_{DD}$	—	$V_{DD}$	
Input low voltage	$V_{IL}$		0	—	$0.3V_{DD}$	
Output high voltage	$V_{OH}$		$0.7V_{DD}$	—	—	
Output low voltage	$V_{OL}$		—	—	$0.3V_{DD}$	
Logic current consumption	$I_{DD}$		—	210	250	mA

#### 6.2 Backlight Circuit Characteristics(27 LEDs Parallel series connection):

Item	Symbol	Min	Typ.	Max.	Unit	Condition
Operating voltage	$V_{LED}$	-	9.3	10.2	V	$I_{LED}=180\text{mA}$
Operating current	$I_{LED}$	—	120	130	mA	-
Back blight luminance (display white)		—	5000	—	cd/m <sup>2</sup>	$I_{LED}=180\text{mA}$

## 7. Optical Specification

Optical characteristics are determined after the unit has been on and stable for approximately 30 minutes dark environment at 25°C. The values specified are at an approximate distance 500mm from the LCD surface at a viewing angle  $\theta$  equal to 0.

### 7.1 LCD Optical Characteristics

Ta=25°C

parameter		Symbol	Condition	Min	Typ	Max	Unit
Viewing Angle	$\Phi = 90^\circ$	$\theta$	$Cr > 10$	-	70	-	deg
	$\Phi = 270^\circ$			-	75	-	
	$\Phi = 0^\circ$			-	75	-	
	$\Phi = 180^\circ$			-	75	-	
Contrast ratio		Cr	$\theta=0$	-	700	-	
Response time		Tr+Tf	$\Phi=0$	-	20	-	ms
Surface Luminance		Lv		-	250	-	Cd/m <sup>2</sup>
CIE(x,y) chromaticity	RED	X	$\theta=0$ $\Phi=0$	0.557	0.607	0.657	
		Y		0.302	0.352	0.402	
	GREEN	X		0.283	0.333	0.383	
		Y		0.535	0.585	0.635	
	BLUE	X		0.098	0.148	0.198	
		Y		0.036	0.086	0.136	
	WHITE	X		0.253	0.313	0.373	
		Y		0.271	0.331	0.391	

### 7.2 Measurement system

#### (1) LCD Viewing Angle

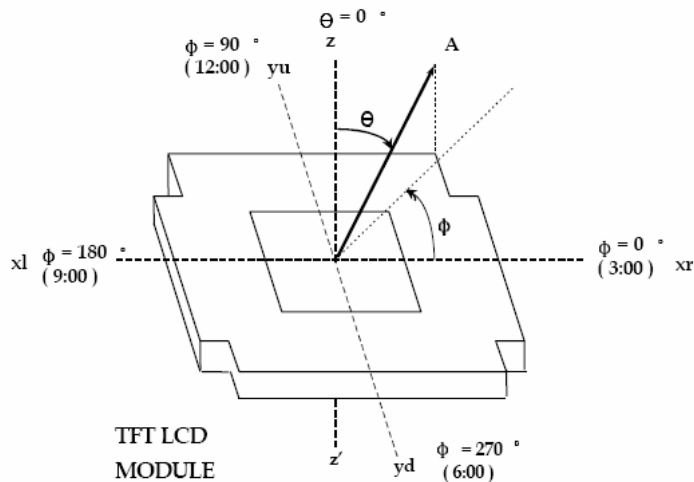

viewing angle is the angle at which the contrast ratio is greater than 10. The angles are determined for the horizontal or x axis and the vertical or y axis with respect to the z axis which is normal to the LCD surface.

---

(2) Response time

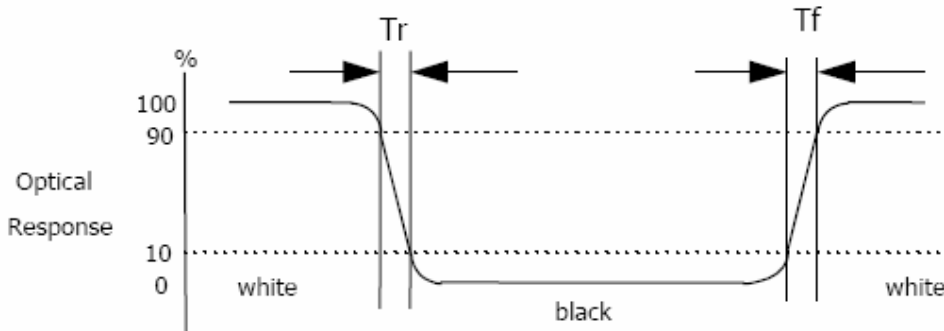

Response time is the time required for the display to transition from white to black (Rising time, Tr) and from black to white (Falling time, Tf).for additional information

(3) Contrast Ratio(CR)

Contrast Ratio(CR) is defined mathematically as:

$$\text{Contrast Ratio} = \frac{\text{Surface Luminance with all white pixels}}{\text{Surface Luminance with all black pixels}}$$

Surface luminance is the center point across the lcd surface 500mm from the surface with all pixels displaying white.

## 8. Application Circuit

Please consult our technical department for detail information.

## 9. Initial Code

Please consult our technical department for detail information.



## 10 . Reliability and inspection standard

### 10.1 Environment test(reliability test)

Samples OK before testing

Test item	Test condition
High temperature storage	80℃ , 240 hr
Low temperature storage	-30℃ , 240 hr
High temperature operation	70℃ , 160 hr
Low temperature operation	-20℃ , 160 hr
High temperature and high humidity operation	40℃ , 93 %RH , 160 hr
Thermal shock	-30℃ → 25℃ → 80℃ → 25℃ ( 30min ) (5min) (30min) (5min) 20 cycle

After completing the reliability tests,leave the samples under the room temperature and for the following inspection items:

- ① No clearly visible defects or deterioration of display quality allowed.
- ② No function-related abnormalities.
- ③ Connected parts still connecting tightly.
- ④ Display characteristics fulfil initial value , contrast ratio should be an least 30% of initial value.

### 10.2 Ultraviolet radiation irradiation test

After Samples irradiated by ultraviolet radiation,have no deterioration of display quality

### 10.3 Mechanical test

#### 1)Vibration test

Test item	Test content	
In mobile telephone	Reference mobile phone test standard	
Vibration test ( packed )	frequence/acceleration	30Hz/2.5m/s <sup>2</sup>
	direction	X、 Y、 Z 3 direction
	time	30min respectively

After completing the vibration tests,the samples have No function-related abnormalities or structure distortion .

#### 2) Shock test

Peak accelation m/s <sup>2</sup>	Pulseholding time ms	Shock wave
300	11	Half sine wave or back peak sawtooh

---

		wave or trapeziform wave
--	--	--------------------------

After completing the shock tests,the samples have No function-related abnormalities or structure distortion .

**3)packing part drop test**

Test item	Test content	
drop (packed in a box )	height	80cm
	Drop mode	Freedom drop
	Drop part	1 corner/3 arris/6 face,1time respectively

After completing the packing part drop tests,the samples have no function-related abnormalities or structure distortion .

**10.4 Electron magnetic compatibility**

Electrostatic withstanding voltage

After air contact discharge (voltage:  $\pm 8KV$ ) and contact discharge directly (voltage: $\pm 4KV$ ) test, the samples display ok ,and have no flicker、white screen、black screen、blue screen etc.abnormity display.。

## 11 . Inspection standard

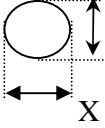
No	Item	Criterion for defects	Defect type																																														
1	Black/white spot defect ( in displaying )	<p>black/white spot definition</p> $\Phi = \frac{(x+y)}{2}$  <p>1. black/white spot defect (I)</p> <table border="1"> <thead> <tr> <th rowspan="2">area size ( mm )</th> <th colspan="3">Acceptable number</th> </tr> <tr> <th>A</th> <th>B</th> <th>C</th> </tr> </thead> <tbody> <tr> <td><math>\Phi \leq 0.1</math></td> <td colspan="3">ignore</td> </tr> <tr> <td><math>0.10 &lt; \Phi \leq 0.15</math></td> <td colspan="3">3</td> </tr> <tr> <td><math>0.15 &lt; \Phi \leq 0.25</math></td> <td colspan="3">2</td> </tr> <tr> <td><math>\Phi &gt; 0.25</math></td> <td colspan="3">0</td> </tr> </tbody> </table> <p>2. black/white spot defect (II)</p> <table border="1"> <thead> <tr> <th rowspan="2">area size ( mm )</th> <th colspan="3">Acceptable number</th> </tr> <tr> <th>A</th> <th>B</th> <th>C</th> </tr> </thead> <tbody> <tr> <td><math>\Phi \leq 0.3</math></td> <td colspan="3">ignore</td> </tr> <tr> <td><math>0.30 &lt; \Phi \leq 0.50</math></td> <td colspan="3">5 (spacebetween is 20mm)</td> </tr> <tr> <td><math>0.50 &lt; \Phi \leq 1.00</math></td> <td colspan="3">3(spacebetween is 50mm)</td> </tr> <tr> <td><math>1.00 &lt; \Phi</math></td> <td colspan="3">0</td> </tr> </tbody> </table>	area size ( mm )	Acceptable number			A	B	C	$\Phi \leq 0.1$	ignore			$0.10 < \Phi \leq 0.15$	3			$0.15 < \Phi \leq 0.25$	2			$\Phi > 0.25$	0			area size ( mm )	Acceptable number			A	B	C	$\Phi \leq 0.3$	ignore			$0.30 < \Phi \leq 0.50$	5 (spacebetween is 20mm)			$0.50 < \Phi \leq 1.00$	3(spacebetween is 50mm)			$1.00 < \Phi$	0			Minor
area size ( mm )	Acceptable number																																																
	A	B	C																																														
$\Phi \leq 0.1$	ignore																																																
$0.10 < \Phi \leq 0.15$	3																																																
$0.15 < \Phi \leq 0.25$	2																																																
$\Phi > 0.25$	0																																																
area size ( mm )	Acceptable number																																																
	A	B	C																																														
$\Phi \leq 0.3$	ignore																																																
$0.30 < \Phi \leq 0.50$	5 (spacebetween is 20mm)																																																
$0.50 < \Phi \leq 1.00$	3(spacebetween is 50mm)																																																
$1.00 < \Phi$	0																																																
2	Black/white line defect( in displaying )	<p>1. black/white line defect (I)</p> <table border="1"> <thead> <tr> <th colspan="2">size ( mm )</th> <th colspan="3">Acceptable number</th> </tr> <tr> <th rowspan="2">L(length)</th> <th rowspan="2">W(width)</th> <th colspan="3">area</th> </tr> <tr> <th>A</th> <th>B</th> <th>C</th> </tr> </thead> <tbody> <tr> <td><math>10 &lt; L</math></td> <td><math>0.03 &lt; W \leq 0.04</math></td> <td colspan="3">5</td> </tr> <tr> <td><math>5.0 &lt; L \leq 10</math></td> <td><math>0.04 &lt; W \leq 0.06</math></td> <td colspan="3">3</td> </tr> <tr> <td><math>1.0 &lt; L \leq 5.0</math></td> <td><math>0.06 &lt; W \leq 0.07</math></td> <td colspan="3">2</td> </tr> <tr> <td><math>L \leq 1.0</math></td> <td><math>0.07 &lt; W \leq 0.09</math></td> <td colspan="3">1</td> </tr> </tbody> </table>	size ( mm )		Acceptable number			L(length)	W(width)	area			A	B	C	$10 < L$	$0.03 < W \leq 0.04$	5			$5.0 < L \leq 10$	$0.04 < W \leq 0.06$	3			$1.0 < L \leq 5.0$	$0.06 < W \leq 0.07$	2			$L \leq 1.0$	$0.07 < W \leq 0.09$	1			Minor													
size ( mm )		Acceptable number																																															
L(length)	W(width)	area																																															
		A	B	C																																													
$10 < L$	$0.03 < W \leq 0.04$	5																																															
$5.0 < L \leq 10$	$0.04 < W \leq 0.06$	3																																															
$1.0 < L \leq 5.0$	$0.06 < W \leq 0.07$	2																																															
$L \leq 1.0$	$0.07 < W \leq 0.09$	1																																															

		<p>2. black/white line defect(II)</p> <table border="1"> <thead> <tr> <th colspan="2">size(mm)</th> <th colspan="3">Acceptable</th> </tr> <tr> <th rowspan="2">L(length)</th> <th rowspan="2">W(width)</th> <th colspan="3">area</th> </tr> <tr> <th>A</th> <th>B</th> <th>C</th> </tr> </thead> <tbody> <tr> <td>20 &lt; L</td> <td>0.05 &lt;</td> <td colspan="3">5</td> <td rowspan="4">ignore</td> </tr> <tr> <td>10 &lt; L ≤ 20</td> <td>0.07 &lt;</td> <td colspan="3">3</td> </tr> <tr> <td>5.0 &lt; L ≤ 10</td> <td>0.09 &lt;</td> <td colspan="3">2</td> </tr> <tr> <td>L ≤ 5.0</td> <td>0.10 &lt;</td> <td colspan="3">1</td> </tr> </tbody> </table>	size(mm)		Acceptable			L(length)	W(width)	area			A	B	C	20 < L	0.05 <	5			ignore	10 < L ≤ 20	0.07 <	3			5.0 < L ≤ 10	0.09 <	2			L ≤ 5.0	0.10 <	1																			
size(mm)		Acceptable																																																			
L(length)	W(width)	area																																																			
		A	B	C																																																	
20 < L	0.05 <	5			ignore																																																
10 < L ≤ 20	0.07 <	3																																																			
5.0 < L ≤ 10	0.09 <	2																																																			
L ≤ 5.0	0.10 <	1																																																			
3	Blemish & foreign matters	<p>1. dot (LCD)</p> <table border="1"> <thead> <tr> <th rowspan="3">size(mm)</th> <th colspan="3">Acceptable number</th> </tr> <tr> <th colspan="3">area</th> </tr> <tr> <th>A</th> <th>B</th> <th>C</th> </tr> </thead> <tbody> <tr> <td><math>\Phi \leq 0.1</math></td> <td colspan="3">ignore</td> <td rowspan="4">ignore</td> </tr> <tr> <td><math>0.10 &lt; \Phi \leq 0.15</math></td> <td colspan="3">2</td> </tr> <tr> <td><math>0.15 &lt; \Phi \leq 0.25</math></td> <td colspan="3">1</td> </tr> <tr> <td><math>0.25 &lt; \Phi</math></td> <td colspan="3">0</td> </tr> </tbody> </table> <p>2. blemish ( on touch panle or between touch panel ane LCD )</p> <table border="1"> <thead> <tr> <th rowspan="3">size(mm)</th> <th colspan="3">Acceptable number</th> </tr> <tr> <th colspan="3">AREA</th> </tr> <tr> <th>A</th> <th>B</th> <th>C</th> </tr> </thead> <tbody> <tr> <td><math>\Phi \leq 0.1</math></td> <td colspan="3">ignore</td> <td rowspan="3">ignore</td> </tr> <tr> <td><math>0.10 &lt; \Phi \leq 0.15</math></td> <td colspan="3">1</td> </tr> <tr> <td><math>0.15 &lt; \Phi</math></td> <td colspan="3">0</td> </tr> </tbody> </table> <p>3.line ( LCD/touch panle )</p>	size(mm)	Acceptable number			area			A	B	C	$\Phi \leq 0.1$	ignore			ignore	$0.10 < \Phi \leq 0.15$	2			$0.15 < \Phi \leq 0.25$	1			$0.25 < \Phi$	0			size(mm)	Acceptable number			AREA			A	B	C	$\Phi \leq 0.1$	ignore			ignore	$0.10 < \Phi \leq 0.15$	1			$0.15 < \Phi$	0			Minor
size(mm)	Acceptable number																																																				
	area																																																				
	A	B	C																																																		
$\Phi \leq 0.1$	ignore			ignore																																																	
$0.10 < \Phi \leq 0.15$	2																																																				
$0.15 < \Phi \leq 0.25$	1																																																				
$0.25 < \Phi$	0																																																				
size(mm)	Acceptable number																																																				
	AREA																																																				
	A	B	C																																																		
$\Phi \leq 0.1$	ignore			ignore																																																	
$0.10 < \Phi \leq 0.15$	1																																																				
$0.15 < \Phi$	0																																																				

## H2026N700N TFT LCD Module

		size(mm)		Acceptable number		
		L(length)	W(width)	area		
				A	B	C
		Ignore	$W \leq 0.02$	5	ignore	
$L \leq 3.0$	$0.02 <$	3				
$L \leq 2.0$	$0.03 <$	2				
---	$W > 0.05$	Treat with det				
4	Stain on LCD panel surface	Stain which cannot be removed even when wiped lightly with a soft cloth or similar cleaning too are rejectable				Minor
5	Rust in bezel	Rust which is visible in the bezel is rejectable				Minor
6	Defect of land surface contact	Evident crevices which is visible are rejectable				Minor
7	Parts mounting	(1) failure to mount parts (2) parts not in the specification are mounted (3) polarity, for example, is reversed				Major Major Major
8	Parts alignment	(1) LSI, IC lead width is more than 50% beyond pad outline				Minor

## H2026N700N TFT LCD Module

		(2) Chip component is off center and more than 50% of the leads is off the pad outline	Minor
9	Conductive foreign matter	(1) on open space(gnd,manual solder)solder ball is allowed up to $\Phi 0.1\text{mm}$ (1EA). (2) In case of shield space is allowed up to $\Phi 0.2\text{mm}$ (1EA)	Major
10	Faculty PWB correction	(1) due to PWB copper foil pattern burnout,the patter is connected,using a jumper wire for repair;2 or more places corrected per PWB (2) short circuited part is cut,and no resist coating has been performed.	Minor Minor

area definition

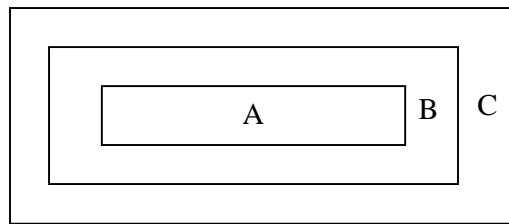

LCD inspection area

A: active area

B: visible area

C: outside of visible area (Invisible area after assembling)

Visible Defect in area c, but it cannot affect product's quality, it is allowed.

## 12. Caution and handling precaution

To avoid causing extended damages such as accidents resulting in injury or death, fire accidents, or social damages or social damages if the lcd module fails, Sunrise is always endeavor to maintain sufficient quality of the lcd module in process of designing and manufacturing.

Please pay attention to the followings when you use this TFT LCD module.

Safety

### 1) disassembling or modification

do not disassemble or modify the modules. sensitive parts inside lcd module may be damaged, and dusts or scratches may mar the displays.

### 2) Breakage of lcd panel

Do not ingest liquid crystal material, do not inhale this material, and do not permit this material to contact the skin, if glass of lcd panel is broken. if liquid crystal material contacts the skin, mouth or

## H2026N700N TFT LCD Module

---

clothing,take the following actions immediately.

In case contact to the eye or mouth,rinse with large amount of running water for more than 15 minutes.in case contact to the skin or clothing,wipe it off immediately and wash with soap and large amount of running water for more than 15 minutes.the skin or clothing may be damaged if liquid crystal material is left adhered.in case ingestion,rinse out the mouth well with water.after spewing up by drinking large amount of water,get medical treatment.

### 3) Glass of lcd panel

be careful with chips of glass that may cause injuring fingers or skin,when the glass is broken.

### 4) Absolute maximum ratings

Do not exceed the absolute maximum rating value under the worst probable condition caused by the supply voltage variation,input voltage variation,variation in parts'constants,environmental temperature,etc.,otherwise lcd module may be damaged.

### 5) power protection circuit

employ protection circuit for power supply,whenever the specification specifies it.

A suitable protection circuit should be applied,based on each system design.

A fuse is not fitted to this module.therefore,without a suitable power-supply protection device,dust or partial circuit failure may cause overheating and/or burning,which may lead to injury.

### 6) Disposal

Always comply with all applicable environmental regulations,when disposing of the lcd.

### 7) Edges of parts

Be careful with edges of glass parts and metal frame,it may cause injuring.

For designing the system,give special consideration that the wiring and parts do not touch those edges.

### 8) Recommended operating conditions

Don't exceed the recommended operation conditions in this specification.the performance and quality of the lcd module are warranted only when the lcd module is used within the recommended operation conditions.to use the lcd module over the recommended operation condition may have bad influence

on the characteristics and reliability of the lcd module and may shorten the life of the lcd module.

Therefore,when designing the whole set,not to be over the recommended operation conditions,you should fully take care of supply voltage change,characteristics of connection parts,serge of input-and-output line,and surrounding temperature.

## 13.Installation in assembly

### 13.1 ESD(electro-static discharge) prevention

The circuit used in lcd module is very sensitive to ESD. The following caution should be taken when installing lcd module to an enclosure of the system in order to prevent damage of circuit used in lcd module.

#### 1) Humidity

Ambient humidity of working area is recommended to be higher than 50%(RH)in order avoid ESD.

#### 2) Grounding

-Person handling lcd modules should be grounded with wrist band.

-Tools like soldering iron and screw drivers and working benches should be grounded.

-Grounded electro-conductive mats are recommended to be covered on the floor of working area and surface of working benched.

-The grounding should be done through a resister of 0.5-1Mohms in order to prevent spark of ESD.

**3) Be careful with touching metal portion of testing instruments in order to prevent unnecessary ESD.**

**4) Do not touch the electrode area of PCB and electrical parts like LSI,capacitor,connector pin,etc.**

**5) Ionizer**

Using ionizer(an antistatic blower)is recommended at working area in order to reduce electro-static voltage.

**6) Removing protection film**

When removing protection film from lcd panel,peel off the tag slowly(more than one second)while blowing with ionizer toward the peelong face to minimize ESD which may damage electrical circuit.

**13.2. Dust and stain prevention**

**1) Working area**

Reduce dust level in working area.especially the level of metal particle should be decreased,otherwise electrical circuit in lcd module may be damaged due to short circuit by metal particles.

**2) Protection film**

Lcd module may be shipped with protection film on lcd panle in order to prevent from scratches and dust.it is recommended to remove the film at later process of assembling.

**3) Wiping off dust on the panel**

When lcd panel becomes dirtu,wipe the panle surface off softly with absorbent cotton or another soft cloth.if necessary,breathe upson the panle surface and then wioe odd immediately and softly again.be careful not to spill organic solvents into the inside of lcd module.the solvents may be damaged by the solvents,so do not use any organic solvents for wiping off lcd panel.

**4) Adhesive on lcd panel**

Be careful not to attach adhesive,grease.etc.,on lcd panel,because it is difficult to remove them without any damages on lcd panel.

**5) Water spots on the panel**

Avoid the dewing or water condensation.

Wipe off a spot or mist on lcd panel softly with absorbent cotton another cloth as soon as possible if happened,otherwiae discoloration or stain may be caused.and ,damage may occur if water penetrates the inside.

**13.3.Installing lcd module to the enclosure**

**1) Installing lcd module to the enclosure**

Do not bend or twist lcd module even momentarily when the lcd module is installed into the system.



Bending or twisting the lcd module may cause permanent damage.

When the FPC is bent, the radius of FPC curvature must be more than value of recommendation to prevent bending and twisting forces from affecting the connection of FPC.

Even temporary bending or twisting sometimes causes damage.

## **2) Interface**

Do not fasten screw, with catching interface FPC between lcd module and enclosure.

This may cause bending of lcd module, or become the cause of a failure by damaging FPC.

## **13.4. Mechanical forces**

### **1) Carry**

Hold the side of the plastic frame when you carry an lcd module by hand. If an lcd is carried using the FPC, it is likely to be damaged and the lcd will then malfunction. If you turn on the lcd with a broken FPC, it may cause smoke or burning.

Protection (eg gloves) for fingers and hands is recommended to avoid injury by broken glass.

### **2) Strong mechanical shock**

Avoid strong mechanical shock, such as dropping the lcd from the work bench, or knocking it against a hard object.

### **3) Excessive force**

Avoid applying excessive force, like pushing the surface of lcd panel. This may cause scratches or breakage of the panel, or a failure of the module.

### **4) Scratches on the panel**

Do not put heavy object such as tools, books, etc., and do not pile up lcd modules.

Be careful not to touch the surface of the polarizer with any hard and sharp object. These parts are so sensitive and can easily be scratched, even if protected by a film.

### **5) Connector**

When inserting or disconnecting the connector into a connector of the lcd module, care should be taken to ensure that no strong external force is applied to the connector on the lcd module side.

A strong external force applied to the connector or the FPC may damage that no part such as the FPC etc. should be caught between the case of the system and the module. Make sure that the input signal connector of a module is securely and correctly connected to the connector on the system, not skewed, or incompletely connected.

Inputting a signal etc. into the module with connectors incorrectly inserted may cause a circuit component or components to malfunction.

### **6) FPC**

When inserting or disconnecting the connector of the lcd module into a connector of the system, care should be taken to ensure that no strong external force is applied to the FPC on the lcd module side. A strong external force applied to the FPC may damage their connections.

When assembling a module into a system, pay extra attention to ensure that no part such as the FPC etc. should be caught between the case of the system and the module.

Make sure that the input signal connector of a module is securely and correctly connected to the connector on the system, not skewed, or incompletely connected. Inputting a signal etc. into the

## H2026N700N TFT LCD Module

---

module with connectors incorrectly inserted may cause a circuit component or components to malfunction. be careful not to pull or damage the FPC cables, to avoid mechanical damage in FPC and connection part of FPC and cell.

### 13.5. Operation

#### 1) Power supply

Power supplies should always be turned off during the assembly process.

Do not connect or disconnect the power cables and connectors with power applied to lcd module. this may cause damage to the lcd module circuit.

In operating module at the inspection process, and so on, the supply voltage and signals of driving device must satisfy the sequence of power supplies and signals described in this specifications.

#### 2) Gas

Do not expose the lcd module to any gas which is not normally contained in the atmosphere, it may cause mis-operation or defects.

#### 3) Used for long term

When a lcd module is used for a long term, the characteristics of lcd module might be changed and it may be out of the standard of optical specifications due to LED discoloration.

LED has the characteristics of shifting optical characteristics by the long term use

## 14. Transportation and storage

### 1) temperature

do not store lcd module in a high temperature and high humidity condition, high than 35°C and 70%(RH) for a long term, meaning about one month or more, otherwise this may deteriorate the quality of the display. when you unavoidably store lcd modules for a long time, store between 0 and 35°C and with a relative humidity 70% or lower.

### 2) Low temperature

Be careful not to leave it where the temperature is below specified storage temperature because the liquid crystal of the display panel may be damaged.

### 3) Ultra violet ray

Store lcd module without exposure to direct sunlight or fluorescent lamps in order to prevent the

Version: 0.2 2012-12-24

## H2026N700N TFT LCD Module

---

module from strong ultra violet ray.

### **4) Cleanliness**

Keep the lcd module in clean place,because any dust,hard particle may damage the polarizer,or dust invades the inside of the lcd module.

### **5) Condensation of water**

The module should be stored under a condition where no condensation of water is allowed.it may cause mis-operation or defects.be especially careful not to make a module work under the condition that condensation of water appears.

### **6) Packing**

When you must re-package a lcd module after it has been removed from the original packaging,it is recommended to re-pack using the original package box and package material.

15. Outline Dimension

