

BL-8723

Product Specification

IEEE802.11 b/g/n WIFI + BT 2.1/3.0/4.0

USB MODULE

Version: 1.0

Contents

1.	General Description	2
2.	Features	2
3.	DCCharacteristics	4
4.	Functional Specifications	5
5.	Block Diagram	7
6.	Module Pin Definition.....	8

1. General Description

BL-8723 is a small size and low profile WiFi+BT combo module at LGA (Land-Grid Array) footprint: 19.5mmx12.5mm, with module height at 1.5mm.

It is a wireless USB adapter based on Realtek RTL-8723 chip, with low power consumption, high linearity output power, IEEE802.11 b/g/n standard and up to 150Mbps wireless transmission (1x1 802.11n b/g/n MIMO technology).

The Bluetooth standard can be BT2.1+EDR / BT3.0 / BT4.0.

2. Features

General Features	Implementation
Power supply	VCC_3.3V +-0.2V
Clock source	40Mhz
Temperature range	Work temperature: -20°C ~ +70°C Storage temperature: -40°C ~ +80°C
Antenna Pin	Connect to the 6 th pin of the module
Package	SMT 10 pins

WLAN and BT features	
General features	<ul style="list-style-type: none">■ CMOS MAC, Baseband PHY, and RF in a single chip for IEEE 802.11b/g/n compatible WLAN■ Complete 802.11n solution for 2.4GHz band■ 72.2Mbps receive PHY rate and 72.2Mbps transmit PHY rate using 20MHz bandwidth■ 150Mbps receive PHY rate and 150Mbps transmit PHY rate using 40MHz bandwidth■ Compatible with 802.11n specification■ Backward compatible with 802.11b/g devices while operating in 802.11n mode■ Qualified BT 2.1, BT 3.0 and BT 4.0 Dual mode■ Support for Bluetooth Low Energy■ Integrated class 1, class 2, and class 3 PA and modem in Bluetooth Controller
Host Interface	<ul style="list-style-type: none">■ Complies with USB Specification Revision 2.0
	<ul style="list-style-type: none">■ IEEE 802.11b/g/n compatible WLAN

Standards Supported	<ul style="list-style-type: none"> ■ IEEE 802.11e QoS Enhancement (WMM) ■ IEEE 802.11h TPC, Spectrum Measurement ■ 802.11i (WPA, WPA2). Open, shared key, and pair-wise key authentication services ■ BT v2.1, EDR/BT v3.0 and HS/BT v4.0
WLAN MAC Features	<ul style="list-style-type: none"> ■ Frame aggregation for increased MAC efficiency (A-MSDU, A-MPDU) ■ Low latency immediate High-Throughput Block Acknowledgement (HT-BA) ■ Long NAV for media reservation with CF-End for NAV release ■ PHY-level spoofing to enhance legacy compatibility ■ Power saving mechanism ■ Channel management and co-existence ■ Transmit Opportunity (TXOP) Short Inter-Frame Space (SIFS) bursting for higher multimedia bandwidth
WLAN PHY Features	<ul style="list-style-type: none"> ■ IEEE 802.11n OFDM ■ One Transmit and one Receive path (1T1R) ■ 20MHz and 40MHz bandwidth transmission ■ Short Guard Interval (400ns) ■ DSSS with DBPSK and DQPSK, CCK modulation with long and short preamble ■ OFDM with BPSK, QPSK, 16QAM, and 64QAM modulation. Convolutional Coding Rate: 1/2, 2/3, 3/4, and 5/6 ■ Maximum data rate 54Mbps in 802.11g and 150Mbps in 802.11n ■ Switch diversity for DSSS/CCK ■ Hardware antenna diversity ■ Selectable receiver FIR filters ■ Programmable scaling in transmitter and receiver to trade quantization noise against increased probability of clipping Fast ■ Receiver Automatic Gain Control (AGC) ■ On-chip ADC and DAC
BT Controller	<ul style="list-style-type: none"> ■ 1Mbps for Basic Rate; 2,3Mbps for Enhanced Data Rate; 6,9,12,18,24,36,48,54Mbps for High Speed ■ AFH, Time Division for Media Access Control ■ 8DPSK, $\pi/4$ DQPSK, GFSK for Modulation Techniques ■ PCM interface for audio data transmission via BT controller. ■ Integrated MCU to execute Bluetooth protocol stack ■ Support all packet types in basic rate and enhanced data rate ■ Support SCO / eSCO link (allow one link for PCM interface and three links for HS-UART) ■ Support 4 piconets in a scatternet ■ Support Secure Simple Pairing ■ Support Low Power Mode (Sniff / Sniff Sub-rating / Hold / Park) ■ Enhanced BT/WIFI Coexistence Control to improve transmission

	<p>quality in different profiles</p> <ul style="list-style-type: none"> ■ Bluetooth 4.0 Dual Mode support: Simultaneous LE and BR/EDR ■ Support multiple states of Low Energy to increase the flexibility of application
Bluetooth Transceiver Features	<ul style="list-style-type: none"> ■ Fast AGC control to improve receiving dynamic range ■ Support AFH to dynamically detect channel quality to improve transmission quality ■ Integrated internal class 1, class 2, and class3 PA ■ Bluetooth 3.0+HS compliant ■ Power Control / Enhanced Power Control Supported ■ Bluetooth Low Energy supported ■ Integrated 32K oscillator for power management

3. DC Characteristics

Symbol	Parameter	Minimum	Typical	Maximum	Units
VD33A, VD33D	3.3V I/O Supply Voltage	3.0	3.3	3.6	v
VD28A, VD28D	1.2V Core Supply Voltage	1.10	1.2	1.32	v
VD15A, VD15D	1.5V Supply Voltage	1.425	1.5	1.575	v

4. Functional Specifications

Standards	WiFi: IEEE802.11b, IEEE802.11g, Draft IEEE802.11n, IEEE802.11d, IEEE802.11e, IEEE802.11h, IEEE802.11i BT: V2.1+EDR, BT v3.0, BT v3.0+HS
Bus Interface	USB 2.0
Form Factor	19.5mm x 12.5mm x 1.5mm (L x W x H)
Data Rate	802.11b: 11, 5.5, 2, 1 Mbps 802.11g: 54, 48, 36, 24, 18, 9, 6 Mbps 802.11n: MCS 0 to 7 for HT20Mbps MCS 0 to 7 for HT40Mbps BT: 1Mbps for Basic Rate 2.3Mbps for Enhanced Data Rate 6, 9, 12, 18, 24, 36, 48, 54 Mbps for High Speed
Media Access Control	WiFi: CSMA/CA with ACK BT: AFH, Time Division
Modulation Techniques	802.11b: CCK, DQPSK, DBPSK 802.11g: 64QAM, 16 QAM, QPSK, BPSK 802.11n: 64QAM, 16 QAM, QPSK, BPSK BT: 8DPSK, $\pi/4$ DQPSK, GFSK
Network Architecture	WiFi: Infrastructure mode Software AP WiFi Direct BT: Pico Net Scatter Net
Operating Channel	WiFi 2.4GHz: 11: (Ch. 1-11) – United States

	13: (Ch. 1-13) – Europe 14: (Ch. 1-14) – Japan BT 2.4GHz: Ch. 0-78		
Frequency Range	2.400GHz ~ 2.4835 GHz		
Transmit Output Power – 1x1 (Tolerance: +/-1.5dBm)	802.11b@11Mbps 16dBm	802.11g@6Mbps 16dBm 802.11g@54Mbps 14dBm	802.11n 16dBm(MCS0_HT20) 13dBm(MCS7_HT20) 13dBm(MCS0_HT40) 13dBm(MCS7_HT40)
	BT: -89dBm@1Mbps, -90dBm@2Mbps, -83dBm@3Mbps		
Receiver Sensitivity	802.11b@11Mbps -82dBm	802.11g@54Mbps -71dBm	802.11n -67dBm(MCS7_HT20) -64dBm(MCS7_HT40)
	BT: -80dBm@1Mbps, -90dBm@2Mbps, -83dBm@3Mbps		
Security	WiFi: WPA, WPA-PSK, WPA2, WPA2-PSK, WEP 64bit & 128bit, IEEE 802.11x, IEEE 802.11i BT: Simple Pairing		
Operating Voltage	3.3V +/- 9% I/O supply voltage		
Power Consumption (3.3V) (Typical)	WiFi: TX Mode: (Continuous mode) 190mA (MCS7/BW40/13dBm) RX Mode: (Continuous mode) 150mA (MCS7/BW40/-60dBm) Associated Idle: 120mA Unassociated Idle: 130mA RF disable Mode: 120mA BT: Inquiry & Page Scan: 1.7mA ACL no traffic: 15mA SCO HV3: 30mA Parked 1.28s beacon: 1.12mA Reset: 0.05mA		

5. Block Diagram

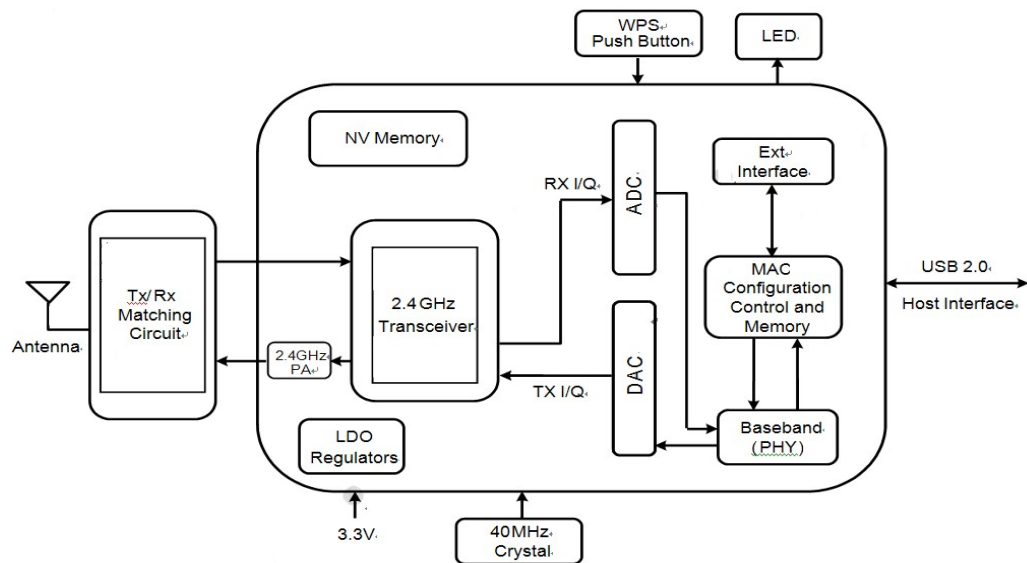
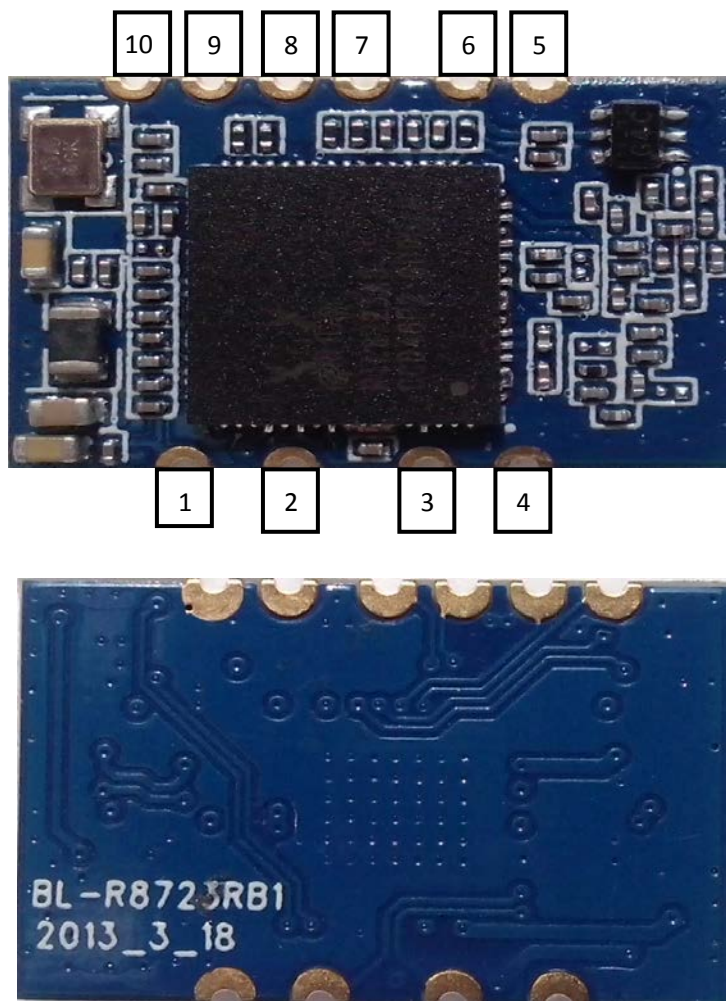

Figure 1. Single-Band 11n (1x1) Solution (11n 1x1 MAC/BB/RF+PA)

6. Module Pin Definition



Top and bottom view

Pin No	TYPE	Description
1	P	DC:3.3V
2	I/O	UDM-
3	I/O	UDP+
4	P	GND
5	P	GND
6	O	ANT
7	P	BT_PCM_SYNC
8	P	BT_PCM_CLK
9	P	BT_PCM_IN
10	P	BT_PCM_OUT