

## Three-Channel, 5th Order, Standard Definition Video Filter Driver BL1513

### Description

The BL1513 is a low-Voltage, three-channel video amplifier with integrated reconstruction filter and input clamps. Specially suited for standard definition video signals, this device is ideal for a wide range of television and set-top box applications.

BL1513 offers 6dB Gain rail-to-rail output driver and 5th order output reconstruction filter on all three channels. It has 8MHz -3dB bandwidth and 31.25V/ $\mu$ s slew rate. BL1513 provides improved image quality compared with passive LC filters and discrete drivers solution.

BL1513 can be DC-coupled or AC-coupled with input video signal, such as the output stage of DAC to eliminate out-of-band noise. The output in BL1513 can be configured as DC or AC-coupled output.

The BL1513 is available in Green SOP8L. It operates over an ambient temperature range of -40°C to +85°C.

### Features

- Operation Temperature Range: -40°C to 85°C
- Three channel 5th Order 8MHz (SD) Filters
- Transparent Input Clamping
- 6dB Output Driver Gain
- Rail-to-Rail Output
- Input Voltage Range Includes Ground
- AC or DC Coupled Inputs / Outputs
- Operates from 3.3V to 5.5V Power Supply
- Green SOP8 and MSOP8 Packages
- ESD: pass 8kV HBM test

### Applications

Cable and Satellite Set-Top Boxes

Video Amplifiers,

Communications Devices,

Portable and Handheld Products,

Personal Video Recorders,

Video on Demand, DVD Players

**Pin Configuration**

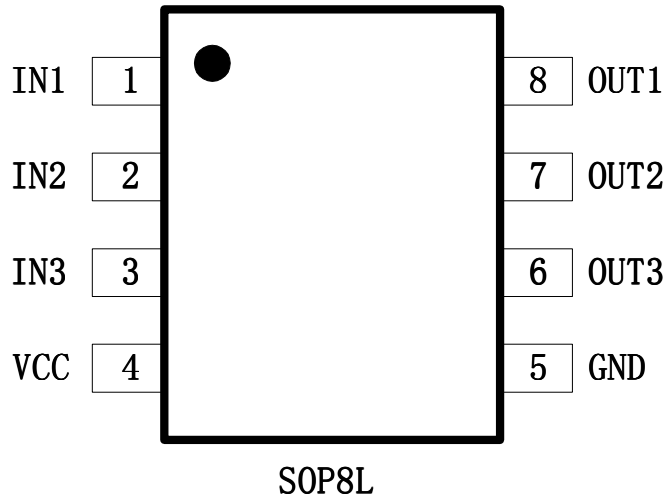

**Block Diagram**

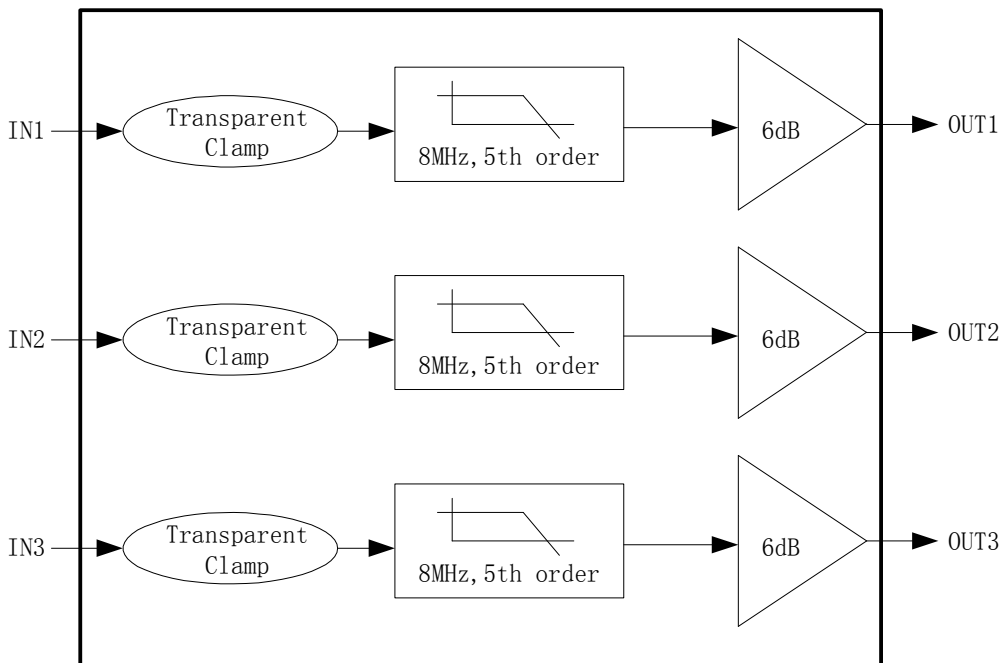

**Pin Description**

No.	Pin Name	Description	I/O
1	IN1	Signal Input	Input
2	IN2	Signal Input	Input
3	IN3	Signal Input	Input
4	VCC	The power pad of the chip	Power
5	GND	The ground pad of the chip	Ground
6	OUT3	Signal Output	Output
7	OUT2	Signal Output	Output
8	OUT1	Signal Output	Output

**ABSOLUTE MAXIMUM RATINGS**

Parameter	Min	Max	Units
Supply Voltage VCC to GND	-0.3	6	V
Input Voltage	GND-0.3	VCC+ 0.3	V
Storage Temperature Range	-65	150	°C
Work Temperature Range	-40	85	°C
Operating Temperature Range T <sub>A</sub>	-40	85	°C

**Notes:**

Stress beyond above listed “Absolute Maximum Ratings” may lead permanent damage to the device. These are stress ratings only and operations of the device at these or any other conditions beyond those indicated in the operational sections of the specifications are not implied. Exposure to absolute maximum rating conditions for extended periods may affect device reliability.

**ORDERING INFORMATION**

MODEL	PIN- PACKAGE	SPECIFIED TEMPERATURE RANGE	PACKAGE MARKING	PACKAGE OPTION
BL1513	SOP8	- 40°C to +85°C	BL1513 YWWSSSS <sup>(1)</sup>	Tape and Reel, 2500

**WHERE(1):**

“Y”stands for the last number of the product year, for example, “2” stands for the year 2012.

“WW” stands for the product week.

“SSSS” stands for the fifth to the eighth number of the lot num.

**ELECTRICAL CHARACTERISTICS**

(At  $V_{CC}=5V$ ,  $R_L = 150\Omega$  connected to GND,  $V_{IN} = 1V_{pp}$ , and  $C_{IN} = 0.1\mu F$ , all outputs AC coupled with  $220\mu F$ , referenced to 400kHz, unless otherwise noted)

<b>DC ELECTRICAL CHARACTERISTICS</b>						
PARAMETER	CONDITIONS	TEMP	MIN	TYP	MAX	UNITS
I <sub>q</sub>	V <sub>IN</sub> =0V	+25°C		21	26	mA
		-40 to +85°C			30	
V <sub>OLS</sub>	V <sub>IN</sub> =0V, NO LOAD	+25°C		395	580	mV
		-40 to +85°C			670	
PSRR	DC	-40 to +85°C		63		dB
Output Voltage High Swing	V <sub>IN</sub> =3V, R <sub>L</sub> = 150Ω connected to GND	+25°C	4.4	4.76		V
		-40 to +85°C	4.3			

<b>AC ELECTRICAL CHARACTERISTICS</b>						
PARAMETER	CONDITIONS	TEMP	MIN	TYP	MAX	UNITS
GAIN (A <sub>V</sub> )	R <sub>L</sub> = 150Ω to GND	+25°C	5.7	6	6.4	dB
		-40 to +85°C	5.4		6.6	
BW (-0.1dB)	R <sub>L</sub> = 150Ω to GND	+25°C		5.5		MHz
BW (-3dB)	R <sub>L</sub> = 150Ω to GND	+25°C		7.7		MHz
Filter response	f <sub>IN</sub> =27MHz	+25°C		49		dB
Crosstalk (channel to channel)	f=1MHz	+25°C		-60		dB
THD	f=1MHz, V <sub>OUT</sub> =1.4V <sub>pp</sub>	+25°C		0.2		%
SLEW RATE	2V outputstep 80% to 20%	+25°C		31.25		V/uS
Fall time	2V outputstep 80% to 20%	+25°C		38.4		nS
Rise time	2V outputstep 80% to 20%	+25°C		38.4		nS
D/DT	difference from 400KHz to 6.5MHz	+25°C		31		nS
DG	PAL DC coupled	+25°C		0.6		%
	PAL AC coupled	+25°C		0.88		
DP	PAL DC coupled	+25°C		0.88		°
	PAL AC coupled	+25°C		1.6		

**Typical Application Diagram**

The following schematic in Figure 2 is normally used for AC coupled output and DC-coupled input with DAC which has an output voltage range of 0V to 1.4V. AC coupled output offer slightly lower power dissipation and high ESD protection ability. The schematics in Figure 1 is also popular in design.



图 1 AC Coupling Application Schematic



图 2 Input DC Coupling Output AC Coupling

---

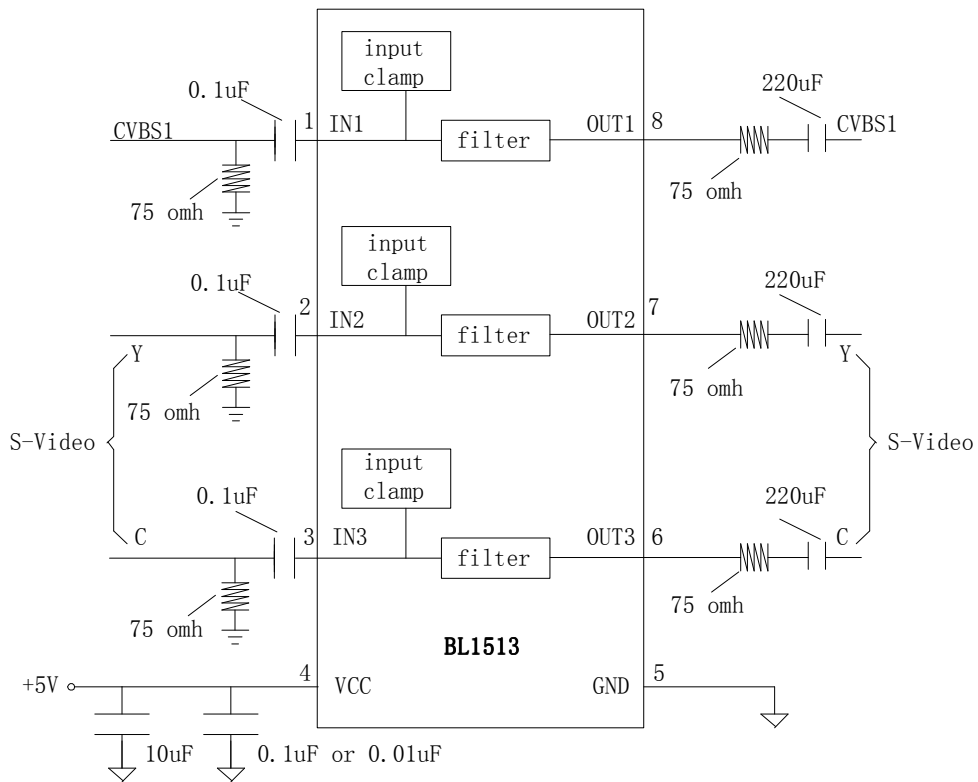
**APPLICATION NOTE****Functional Description**

BL1513 operates from a single 3.3V to 5V supply. In application, BL1513 is a fully integrated solution for filtering and buffering SDTV signals in front of video decoder or behind video encoder. For example, BL1513 can replace three passive LC filters and three amplifier drivers at CVBS and S-video output side in set-top box and DVD player, this solution can help you save PCB size and production cost, it also improves video signal performance comparing with traditional design using discrete components.

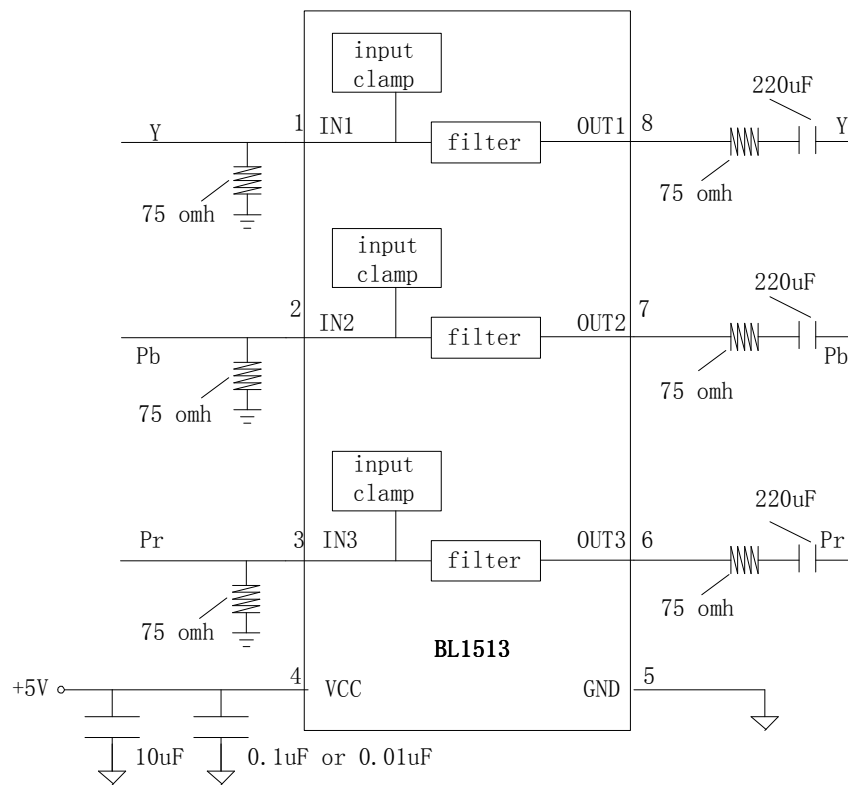
BL1513 features a DC-coupled input buffer, 5-pole low-pass filter to eliminate out-of-band noise of video encoder, and a gain of +6dB in the output amplifier to drive 75Ω load. The AC or DC-coupled input buffer eliminates sync crush, droop, and field tilt. The output of BL1513 also can be DC-coupled or AC-coupled.

**Input Considerations**

Besides AC coupling, the BL1513 inputs also can be DC-coupled. In DC coupling application, No input coupling capacitors are needed because the amplitude of input video signal from DAC includes ground and extends up to 1.4V, then BL1513 can be directly connected to the output of a single-supply, current-output DAC without any external bias network. Some time, if DAC's output level exceeds the range of 0V to 1.4V, or BL1513 is driven by an unknown external source or a SCART switch which has its own clamping circuit, AC coupling is needed in such applications.

**Output Considerations**

The BL1513 outputs can be DC-coupled or AC-coupled. When 0V is input, the BL1513 output voltage is 401mV typically. In DC coupling design, one 75Ω resistor is used to connect BL1513's output pin with external load directly, this serial back-termination resistor is used to match the impedance of the transmission line between BL1513 and external load to cancel the signal reflection. The BL1513 outputs can sink and source current allowing the device to be AC-coupled with external load, in AC coupling, 220μF at least capacitor will be used in order to eliminate field tilt.

**Power-Supply Bypassing and Layout**

Correct power supply bypassing is very important for optimizing video performance in design. One 0.1μF and one 10μF capacitors are always used to Bypass VCC pin of BL1513, please place these two capacitors as close to the BL1513 output pin as possible, a large ground plane is also needed to ensure optimum performance. The input and output termination resistors should be placed as close to the related pin of BL1513 as possible to avoid performance degradation. The PCB traces at the output side should have 75Ω characteristic impedance in order to match the 75Ω characteristic impedance cable connecting external load. In design, please keep the board trace at the inputs and outputs of the BL1513 as short as possible to minimize the parasitic stray capacitance and noise pickup.

**PACKAGE OUTLINE DIMENSIONS (SOP8)**

**SOP8L**

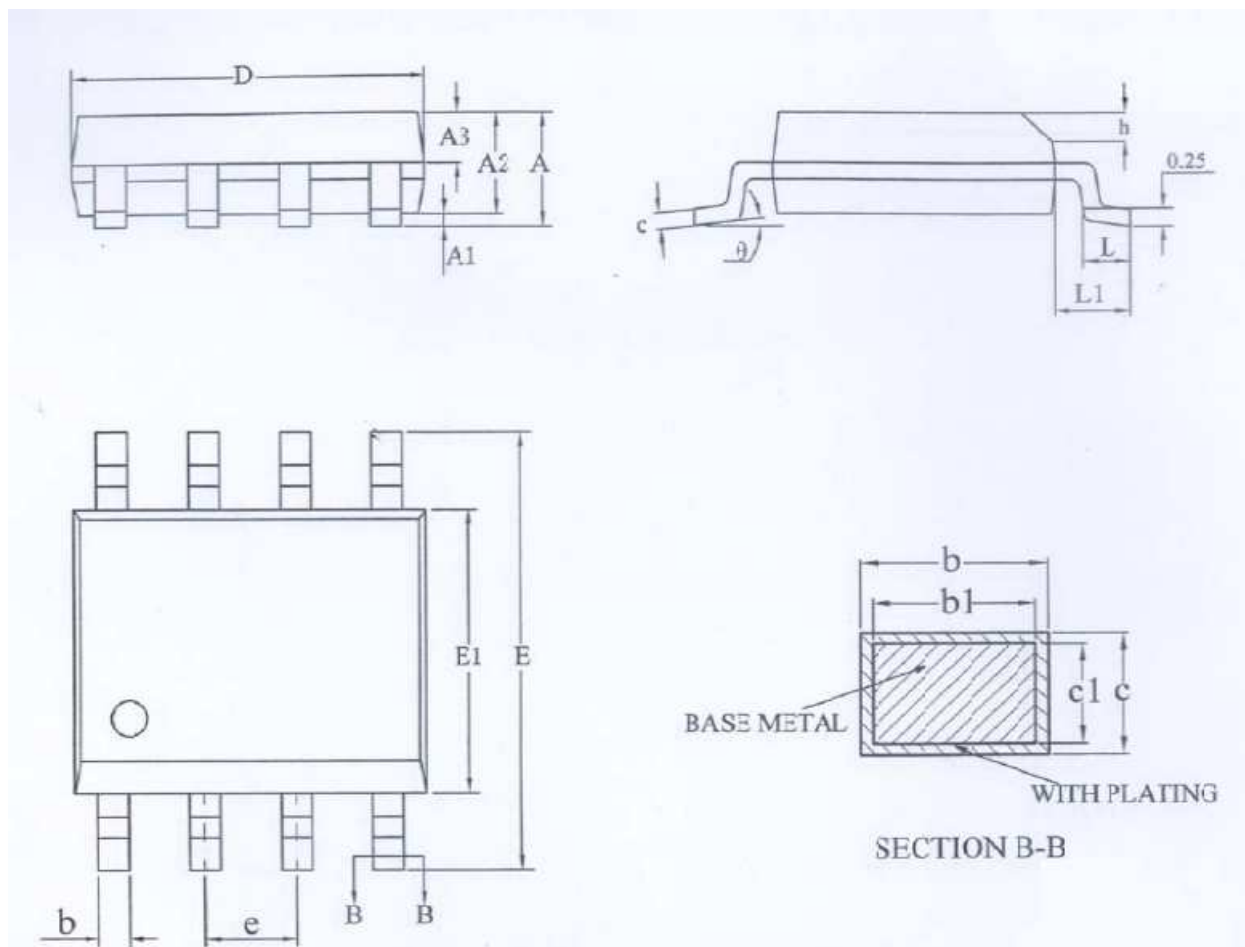

SYMBOL	MILLIMETER		MILLIMETER
	MIN.	NOM	
A	-	-	1.75
A1	0.10	-	0.23
A2	1.30	1.40	1.50
A3	0.60	0.65	0.70
b	0.39	-	0.48
b1	0.38	0.41	0.44
c	0.21	-	0.26
c1	0.19	0.20	0.21
D	4.70	4.90	5.10
E	5.80	6.00	6.20
E1	3.70	3.90	4.10
e	1.27BSC		1.27BSC
h	0.25	-	0.50
L	0.50	-	0.80
L1	1.05BSC		1.05BSC
$\theta$	0°	-	8°