

Dual SPDT Analog Switch with Chip Scale Packaging

Features

- Wide Power Supply Range: 1.65V to 5.5V
- Low On-Resistance:
 - $R_{ON(NC)} = 0.4 \Omega$ ($V_{CC}=2.7V$)
 - $R_{ON(NO)} = 0.5 \Omega$ ($V_{CC}=2.7V$)
- Low On-Resistance Flatness:
 - $R_{ONF(NC)} = 0.15 \Omega$ max ($V_{CC}=2.7V$)
 - $R_{ONF(NO)} = 0.25 \Omega$ max ($V_{CC}=2.7V$)
- Rail-to-Rail Signal Range
- High Off-Isolation: -60dB ($f=100$ kHz)
- Crosstalk Rejection: -67dB
- Low Total Harmonic Distortion: 0.05%
- Lead(Pb) Free CSP-10 Packaging

Applications

- Wireless Handsets
- MP3 Players
- Portable Electronic Devices
- Relay Replacement
- PDAs
- Audio & Video Signal Routing
- PCMCIA Cards
- Computer Peripherals
- Modems

Pin Configuration

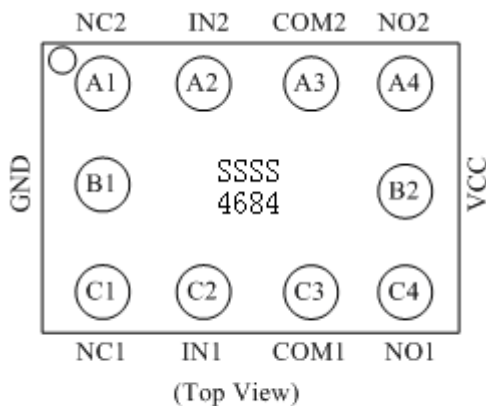

SSSS:NO. 4 to NO. 7 of the LOT Number

Description

The BL4684C is a Dual Wide-Bandwidth, fast single-pole double-throw (SPDT) CMOS switch featuring an On-Resistance of 0.4 ohm at $V_{DD}=2.7V$ and wide power supply range from 1.65V to 5.5V. It can be used as an analog switch or as a low-delay bus switch.

Break-before-make function for both parts eliminates signal disruption during switching from preventing both switches being enabled simultaneously.

Block Diagram

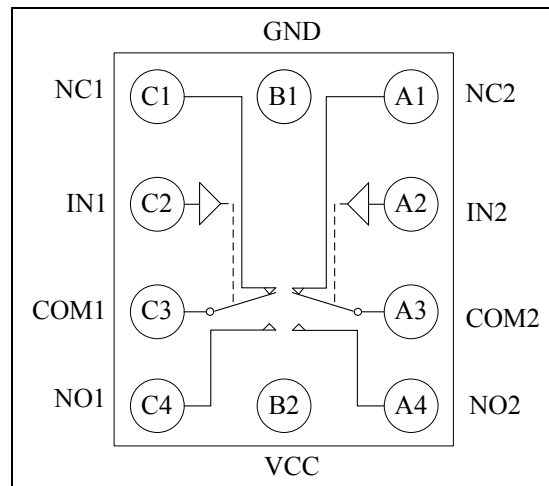

Function Table

IN _x	Function
0	NC _x Connected to COM _x
1	NO _x Connected to COM _x

Pin Description

Pin Name	Type	Description
VCC	PWR	Power Supply
GND	Ground	Ground
COM _x	Input/Output	Data Port
NC _x	Input/Output	Data Port
NO _x	Input/Output	Data Port
IN _x	Input	Logic Control Signal

** X = 1 or 2

ABSOLUTE MAXIMUM RATINGS

Parameter	Symbol	Min	Max	Units
DC Supply Voltage	V_{CC}	-0.5	7	V
DC Switch Voltage	$V_{NCX}/ V_{NOX}/ V_{COMX}$	-0.5	$V_{SUP} + 0.3$	V
DC Input Voltage	V_{INX}	-0.5	7	V
Continuous Current	$I_{(NCX/NOX/COMX)}$	-500	+500	mA
Peak Current ⁽¹⁾	$I_{PEAK(NCX/NOX/COMX)}$	-650	+650	mA
Storage Temperature Range	T_{STG}	-65	150	°C

Notes:

- (1) Pulsed at 1ms, 50% duty circle
- (2) Stress beyond above listed "Absolute Maximum Ratings" may lead permanent damage to the device.
 These are stress ratings only and operations of the device at these or any other conditions beyond those indicated in the operational sections of the specifications are not implied. Exposure to absolute maximum rating conditions for extended periods may affect device reliability.
- (3) Control input(V_{INX}) must be held HIGH or LOW, and mustn't be floated.

RECOMMENDED OPERATING CONDITIONS

DC Supply Voltage (V_{CC})	1.65V to 5.5V
Switch Input Voltage (V_S)	0V to V_{CC}
Control Input Voltage (V_{IN})	0V to V_{CC}
Operation Temperature (TA)	-40°C to +85°C
Input Rise and Fall Time (tf/tr)	0ns/V to 5ns/V
Bump Temperature(Soldering)	
Infared(15s)	+220°C
Vapor Phase(60s)	+215°C

DC ELECTRICAL CHARACTERISTICS @ +3V Supply

Parameter	Symbol	Conditions	Guaranteed Limit			Unit
			Min.	Typ. ⁽¹⁾	Max.	
Analog Switch						
Analog Signal Range	$V_{NOX}/V_{NCX}/V_{COMX}$		0		V_{CC}	V
NC On-Resistance	$R_{ON(NC)}$	$V_{CC} = 2.7V; I_{COM} = 100mA; V_{NC} = 0$ to V_{CC}		0.4	0.5	Ω
NO On-Resistance	$R_{ON(NO)}$	$V_{CC} = 2.7V; I_{COM} = 100mA; V_{NO} = 0$ to V_{CC}		0.5	0.6	Ω
NC On-Resistance Flatness ⁽²⁾	$R_{FLAT(NC)}$	$V_{CC} = 2.7V; I_{COM} = 100mA; V_{NC} = 0$ to V_{CC}			0.15	Ω
NO On-Resistance Flatness ⁽²⁾	$R_{FLAT(NO)}$	$V_{CC} = 2.7V; I_{COM} = 100mA; V_{NO} = 0$ to V_{CC}			0.25	Ω
On-Resistance Match Between Channels ⁽³⁾	ΔR_{ON}	$V_{CC} = 2.7V; I_{COM} = 100mA; V_{NC}$ $/V_{NO} = 1.5$		0.01	0.06	Ω
NC or NO Off Leakage Current	$I_{OFF(NC)}$ OR $I_{OFF(NO)}$	$V_{CC} = 3.3V; V_{NO}$ OR $V_{NC} = 3V, 0.3V;$ $V_{COM} = 0.3V, 3V$	-80		+80	nA
COM On Leakage Current	$I_{ON(COM)}$	$V_{CC} = 3.3V; V_{NO}$ OR $V_{NC} = 3V, 0.3V;$ $V_{COM} = 0.3V, 3V$ or floating	-160		160	nA
Digital I/O						
Input Voltage High	V_{IH}	Minimum High Level Input Voltage	1.3			V
Input Voltage Low	V_{IL}	Maximum Low Level Input Voltage			0.6	V
Input Hysteresis	I_H	$V_{CC} = 3.3V$		200		mV
Input Leakage Current	I_{IN}	$V_{IN} = 0$ or V_{CC}	-1		1	μA

Note:

- (1) Typical characteristics are at +3V supply and +25°C
- (2) Flatness is defined as the difference between the maximum and minimum value of on resistance as measured over the specified analog signal ranges.
- (3) $\Delta R_{ON} = R_{ON(MAX)} - R_{ON(MIN)}$, between NC1 and NC2 or between NO1 and NO2.

DYNAMIC CHARACTERISTICS

Parameter	Symbol	Conditions	Guaranteed Limit			Unit
			Min.	Typ. ⁽¹⁾	Max.	
AC ELECTRICAL CHARACTERISTICS						
Turn-On Time	t_{ON}	$V_{CC} = 2.7V$; V_{NO} or $V_{NC} = 1.5V$, $R_L = 50\Omega$; $C_L = 35pF$, Figure1		25	60	ns
Turn-Off Time	t_{OFF}	$V_{CC} = 2.7V$; V_{NO} or $V_{NC} = 1.5V$, $R_L = 50\Omega$; $C_L = 35pF$, Figure1		8	20	ns
Break-Before-Make Time	t_{BBM}	$V_{CC} = 2.7V$; V_{NO} or $V_{NC} = 1.5V$, $R_L = 50\Omega$; $C_L = 35pF$, Figure2		22		ns
NC OFF Capacitance	$C_{OFF(NC)}$	$f = 1MHz$, Figure6		84		pF
NO OFF Capacitance	$C_{OFF(NO)}$	$f = 1MHz$, Figure6		66		pF
NC ON Capacitance	$C_{ON(NC)}$	$f = 1MHz$, Figure7		245		pF
NO ON Capacitance	$C_{ON(NO)}$	$f = 1MHz$, Figure7		235		pF
ADDITIONAL APPLICATION CHARACTERISTICS						
3dB Bandwidth	f_{3dB}	Figure8		27		MHz
Charge Injection	Q	$V_{GEN} = 0V$; $R_{GEN} = 0\Omega$; $C_L = 1nF$; Figure3		30		pC
Off Isolation ⁽²⁾	V_{iso}	$f = 100kHz$; $R_L = 50\Omega$; $C_L = 5pF$; $V_{COM} = 1 V_{RMS}$; Figure4		-60		dB
Crosstalk ⁽³⁾	V_{CT}	$f = 100kHz$; $R_L = 50\Omega$; $C_L = 5pF$; $V_{COM} = 1 V_{RMS}$; Figure5		-67		dB
Total Harmonic Distortion	THD	$V_{CC} = 3.3V$; $R_L = 32\Omega$; $V_{IN} = 2V_{P-P}$;		0.06		%
Supply						
Power Supply Range	V_{CC}		1.65		5.5	V
Maximum Quiescent Supply Current	I_{CC}	$V_{CC} = 5.5V$; $V_{IN} = V_{CC}$ or 0			200	nA

Note:

- (1) Typical characteristics are at +3V supply and 25°C
- (2) Off Channel Isolation = $20\log_{10} [(V_{NO/NC})/V_{COM}]$
- (3) Between any two switches

TEST SETUP CIRCUITS

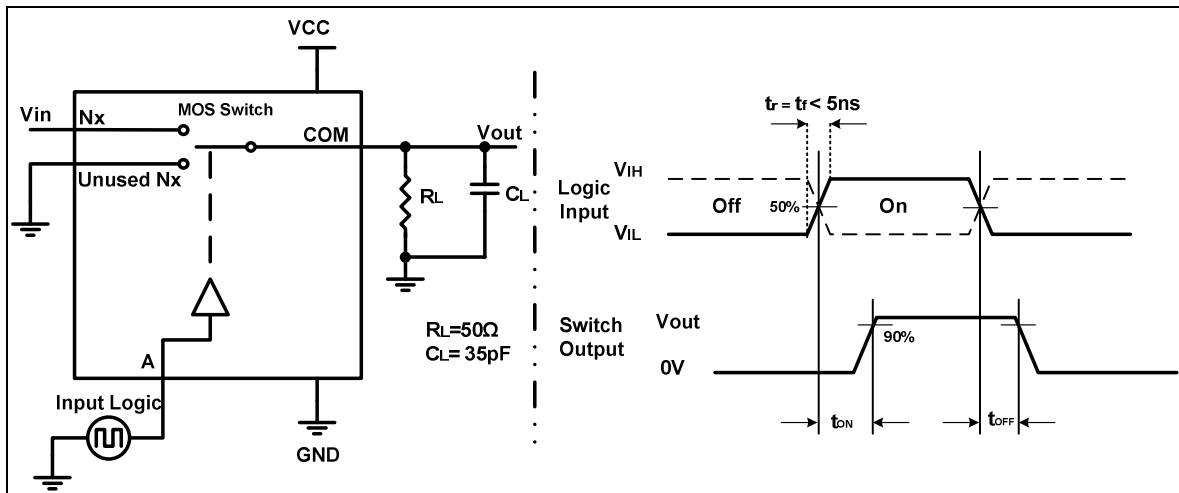

Figure1. AC Test Circuit & Waveforms

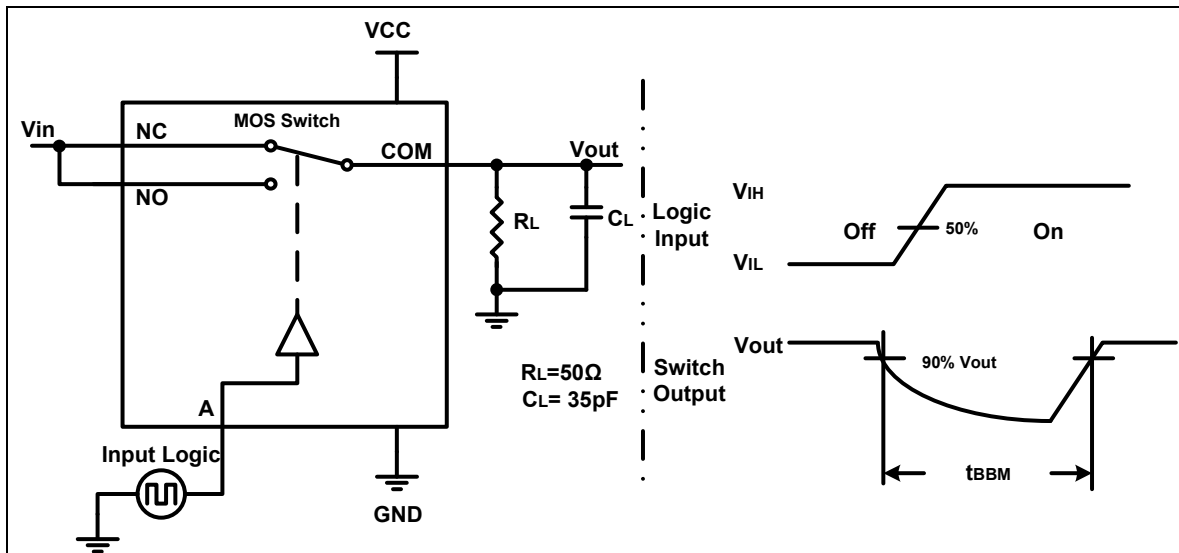

Figure2. Break-Before-Make Time (t_{BBM})

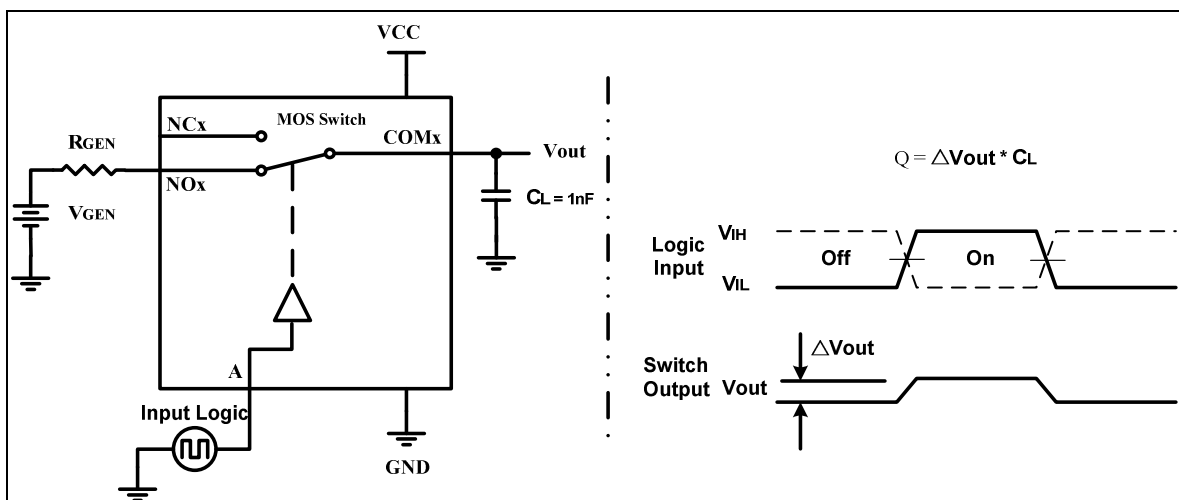

Figure3. Charge Injection (Q)

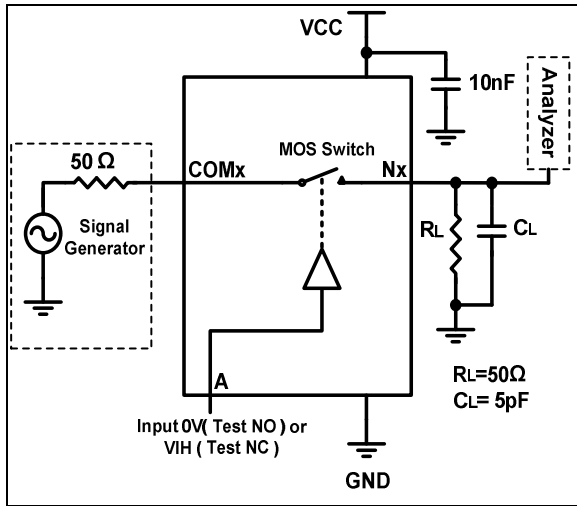

Figure4. Off Isolation (V_{ISO})

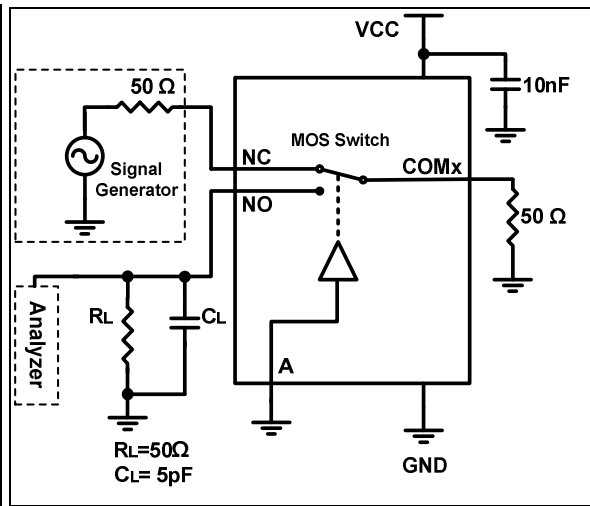

Figure5. Cross Talk (V_{CT})

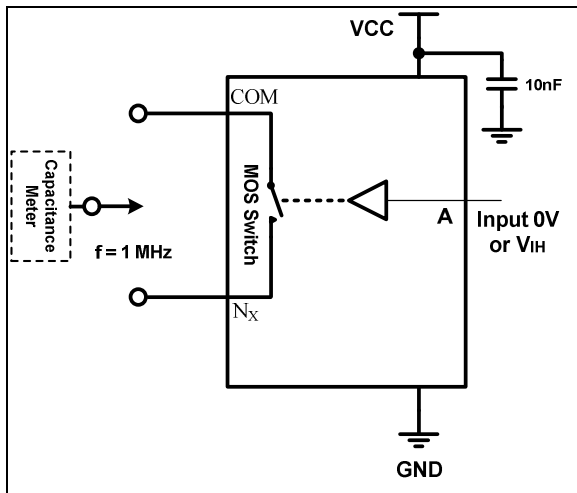

Figure6. Channel Off Capacitance($C_{OFF(NX)}$)

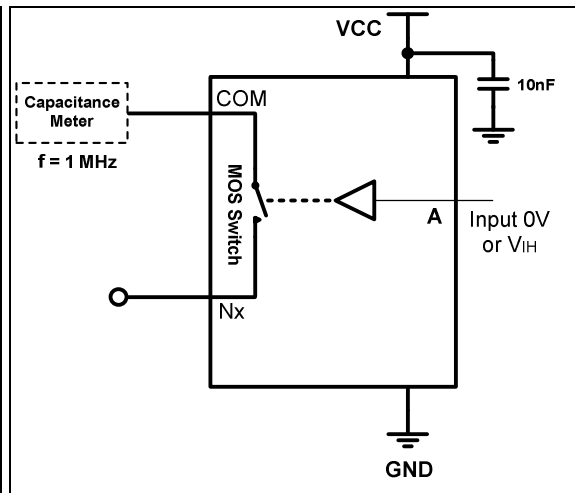

Figure7. Channel On Capacitance($C_{ON(NX)}$)

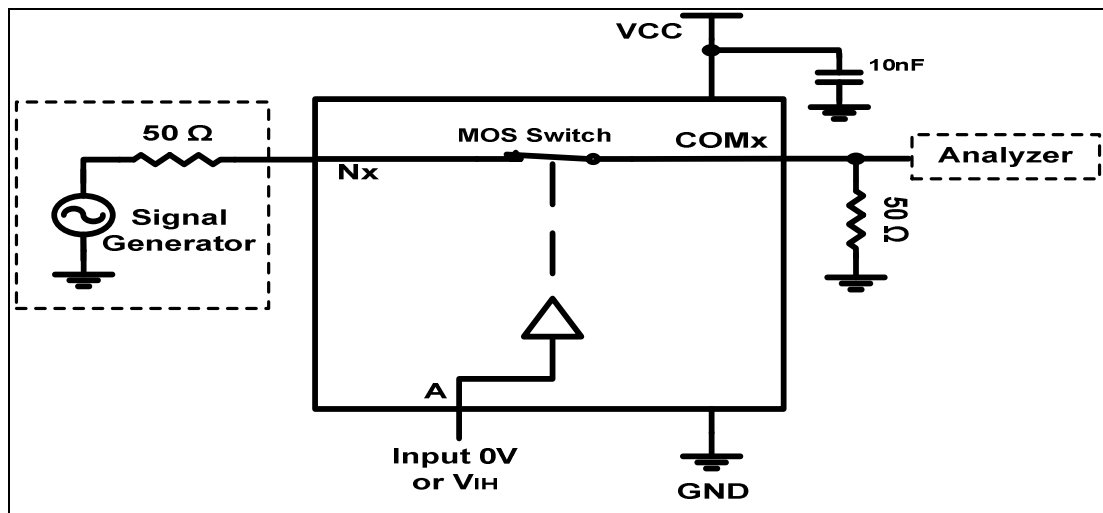

Figure8. -3dB Bandwidth (f_{3dB})

PACKAGE OUTLINE DIMENSIONS (CSP-10)

