

GENERAL DESCRIPTION

The BL7805 series of three-terminal positive regulator are available in the TO-220 package and with several fixed output voltages, making them useful in a wide range of applications. Each type employs internal current limiting, thermal shut down and safe operating area protection, making it essentially indestructible. If adequate heat sinking is provided, they can deliver over 1.2A output current. Although designed primarily as fixed voltage regulators, these devices can be used with external components to obtain adjustable voltages and currents.

FEATURE

- Output Current up to 1.2A
- Thermal Overload Protection
- Short Circuit Protection
- Output Transistor Safe Operating Area Protection
- Output Voltages : 5V

PIN CONNECTIONS

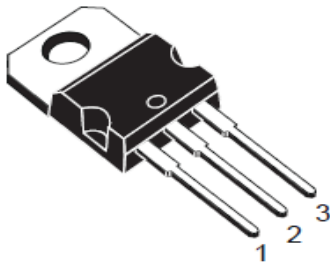

TO-220

BLOCK DIAGRAM

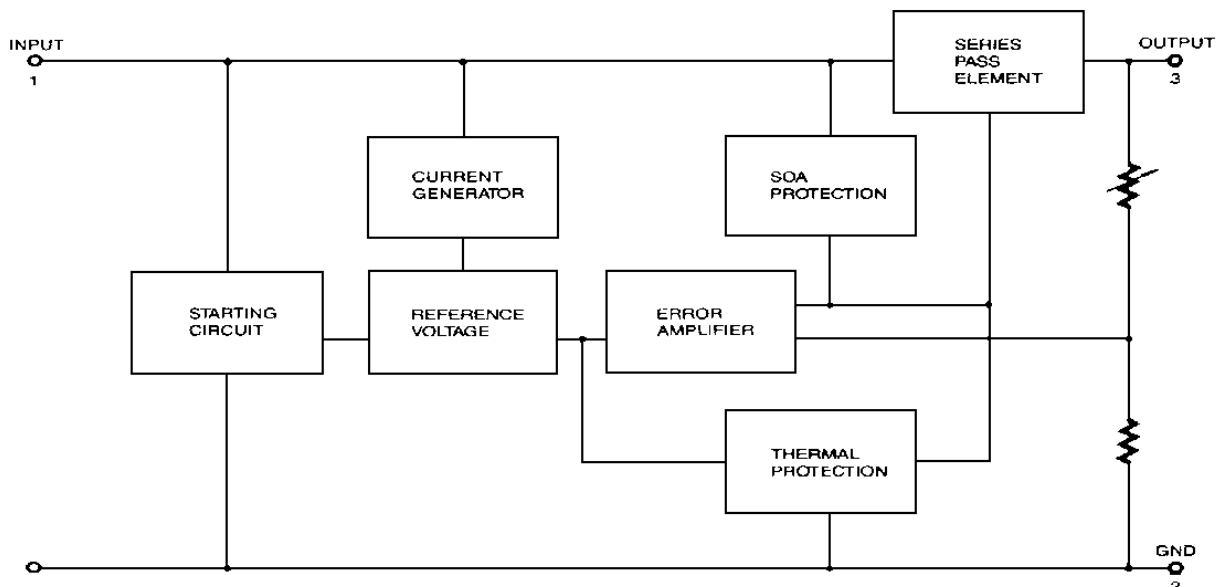

ABSOLUTE MAXIMUM RATINGS (Ta=25°C)

Characteristics	Symbol	Value	Units
Input Voltage	V_i	35	V
Operating Junction Temperature	T_J	150	°C
Storage Temperature Range	T_{STG}	-65~+150	°C

BL7805 ELECTRICAL CHARACTERISTICS

(refer to the test circuits, $T_J = -20$ to 125°C , $V_i = 10\text{V}$, $I_O = 500\text{ mA}$, $C_I = 0.33\ \mu\text{F}$, $C_O = 0.1\ \mu\text{F}$ unless otherwise specified).

Parameter	Symbol	Test Condition	MIN	TYP	MAX	UNIT
Output Voltage	V_O	$T_J = +25^\circ\text{C}$	4.8	5	5.25	V
		$I_O = 5\text{mA to } 1\text{A}$, $P_O \leq 15\text{W}$ $V_i = 8\text{V to } 20\text{V}$	4.65	5	5.35	
Line Regulation	ΔV_O	$T_J = +25^\circ\text{C}$ $V_i = 7\text{V to } 25\text{V}$		3	50	mV
		$T_J = +25^\circ\text{C}$ $V_i = 8\text{V to } 12\text{V}$		1	25	
Load Regulation	ΔV_O	$T_J = +25^\circ\text{C}$ $I_O = 5\text{mA to } 1.2\text{A}$			100	mV
		$T_J = +25^\circ\text{C}$ $I_O = 250\text{mA to } 750\text{mA}$			25	
Quiescent Current	I_Q	$T_J = +25^\circ\text{C}$			6	mA
Quiescent Current Change	ΔI_Q	$I_O = 5\text{mA to } 1\text{A}$			0.5	mA
		$V_i = 14.5\text{V to } 30\text{V}$			0.8	
Quiescent Current Change	$\Delta V_O / \Delta T$	$I_O = 5\text{mA}$		0.6		mV/°C
Ripple Rejection	RR	$f=120\text{Hz}$ $V_i=8\text{V to } 18\text{V}$	62			dB
Dropout Voltage	V_{Drop}	$I_O=1\text{A}$, $T_J=+25^\circ\text{C}$		2.2		V
Short Circuit Current	ISC	$T_J = +25^\circ\text{C}$, $V_i = 35\text{V}$		0.75	1.2	A

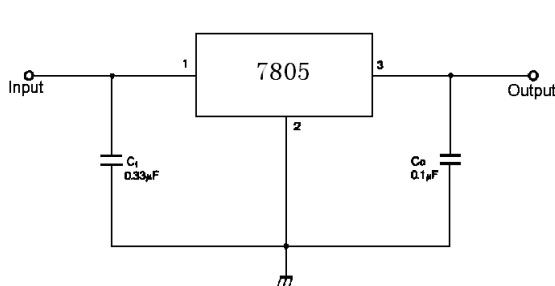
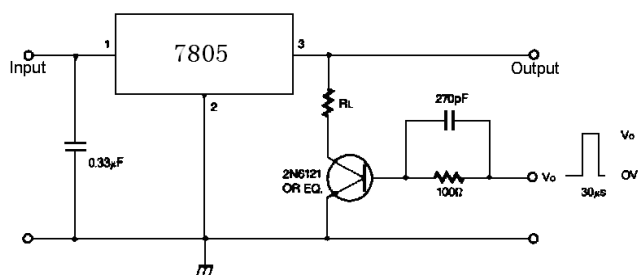
APPLICATION CIRCUIT

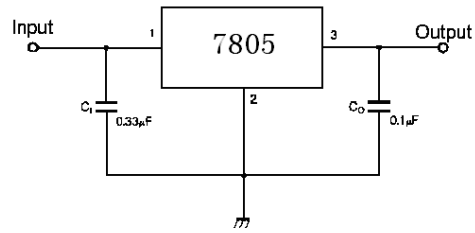
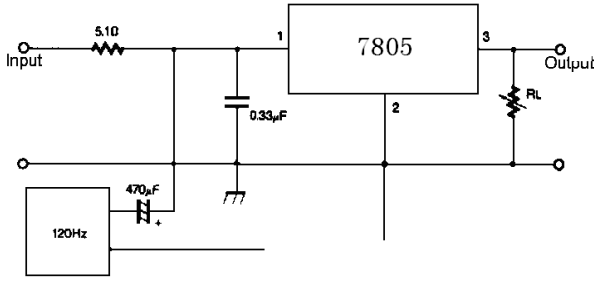
DC Parameters

Load Regulation

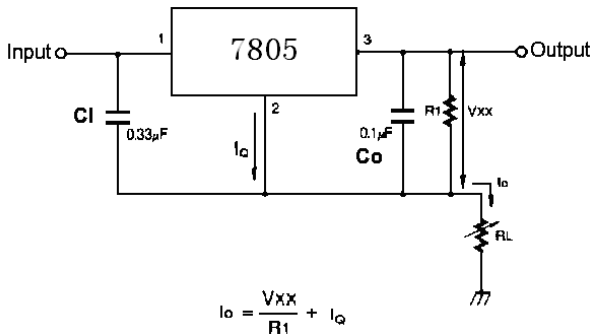

Ripple Rejection

Fixed Output Regulator



Constant Current Regulator

Notes:

- (1) A common ground is required between the input and the Output voltage. The input voltage must remain typically 2.2V above the output voltage even during the low point on the input ripple voltage.
- (2) Ci is required if regulator is located an appreciable distance from power Supply filter.
- (3) Co improves stability and transient response.

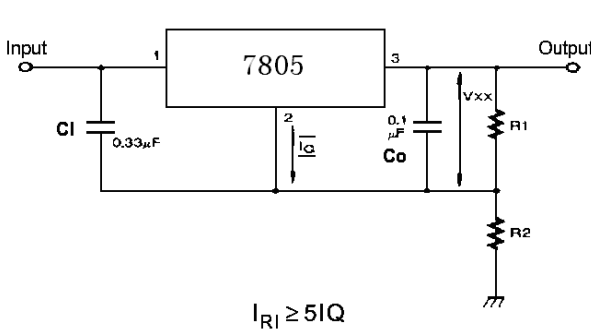

Circuit for Increasing Output Voltage

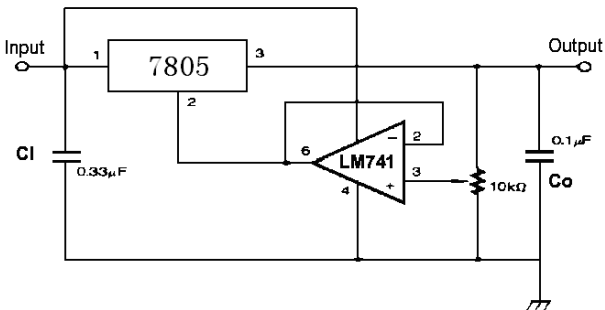

Adjustable Output Regulator (7 to 30V)

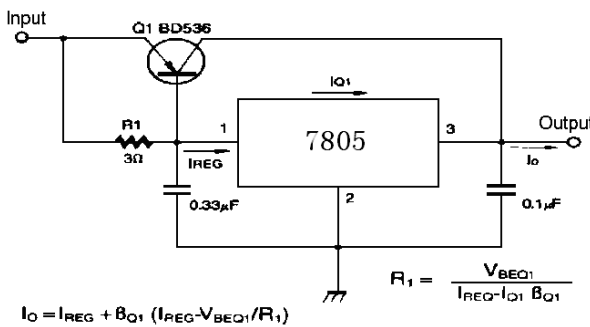

High Current Voltage Regulator
Adjustable Output Regulator (7 to 30V)

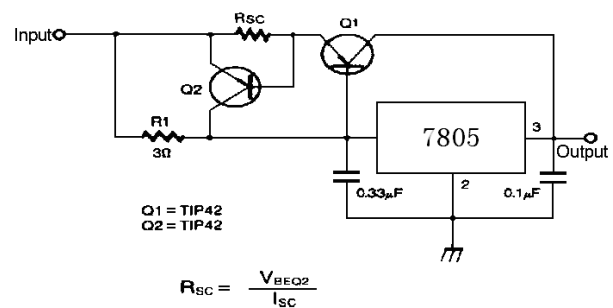

High Output Current with Short Circuit Protection

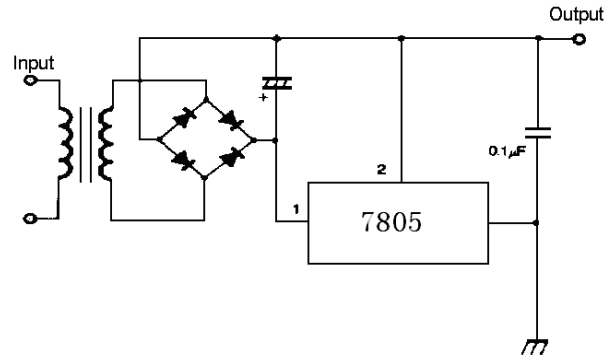
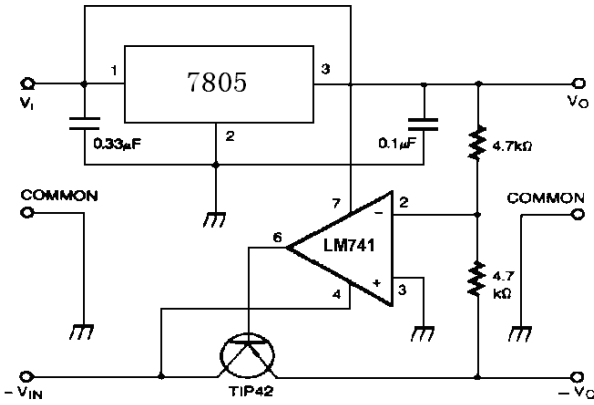

Tracking Voltage Regulator

Negative Output Voltage Circuit

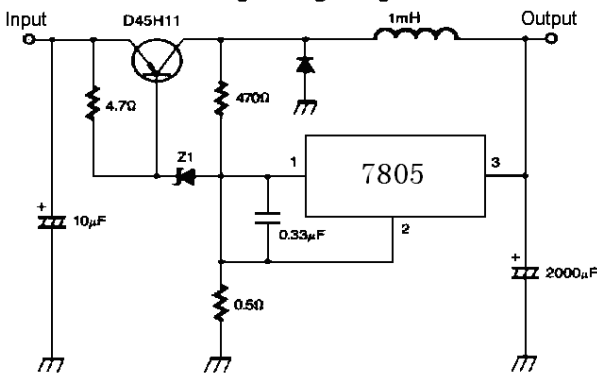

Switching Regulator

Typical Characteristics

Figure 1: Dropout Voltage vs Junction Temperature

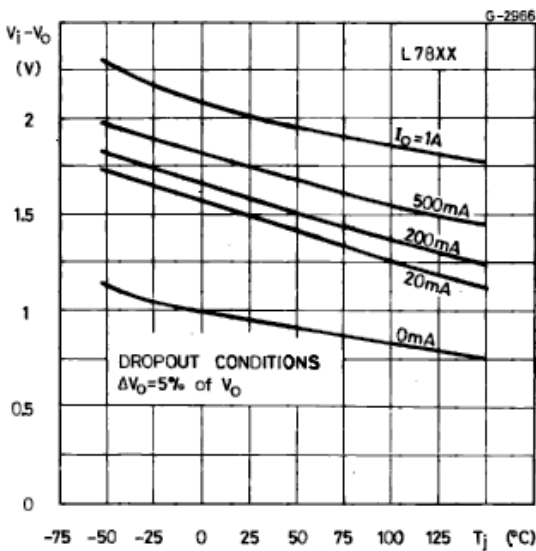

Figure 2: Peak Output Current vs Input/output Differential Voltage

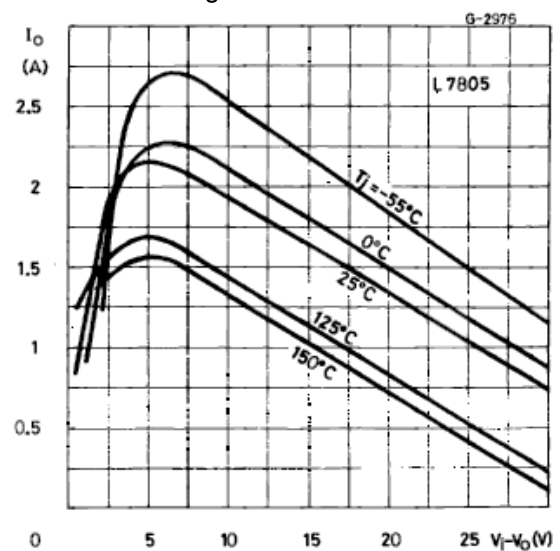

Figure 3:
Supply Voltage Rejection vs Frequency

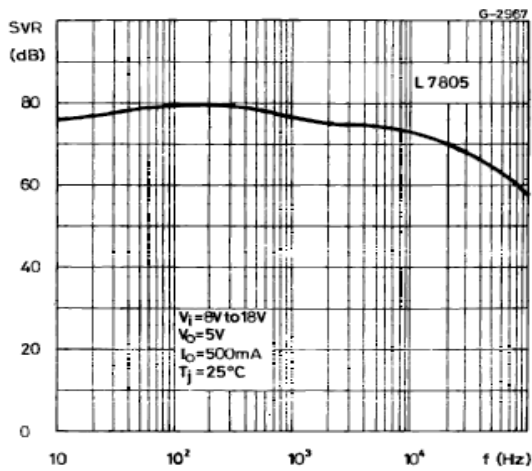

Figure 4:
Quiescent Current vs Junction Temperature

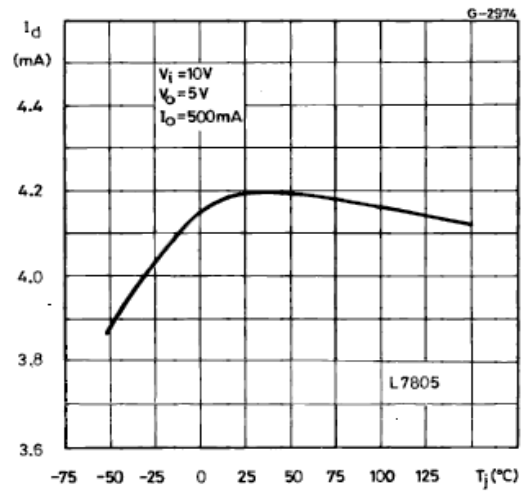

Figure 5:
Output Voltage vs Junction Temperature

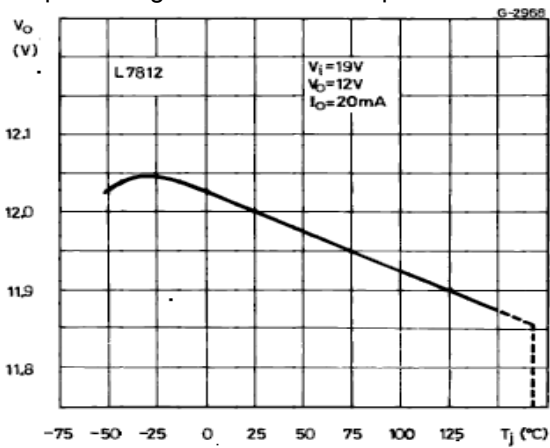

Figure 6:
Load Transient Response

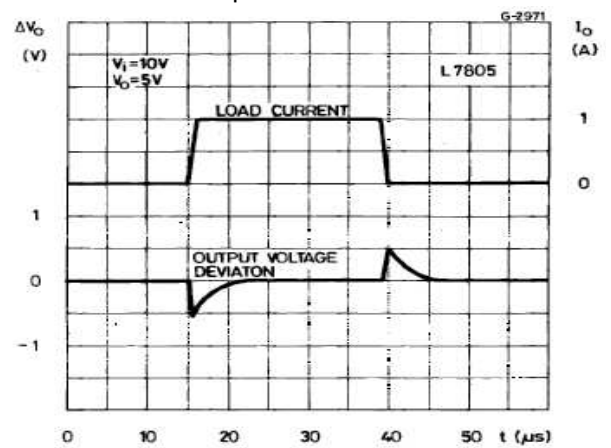

Figure 7:
Output Impedance vs Frequency

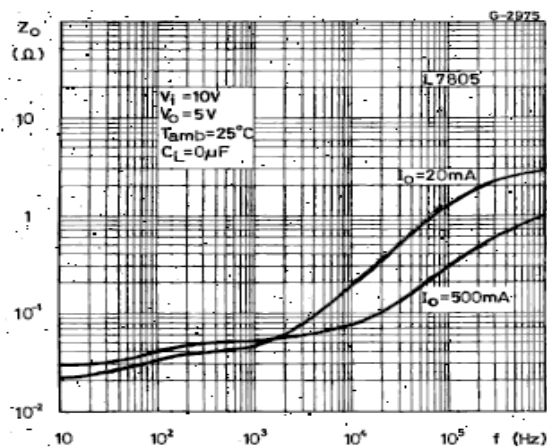

Figure 8:
Line Transient Response

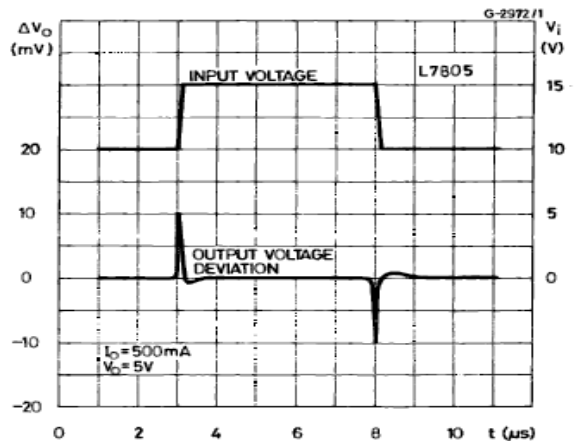
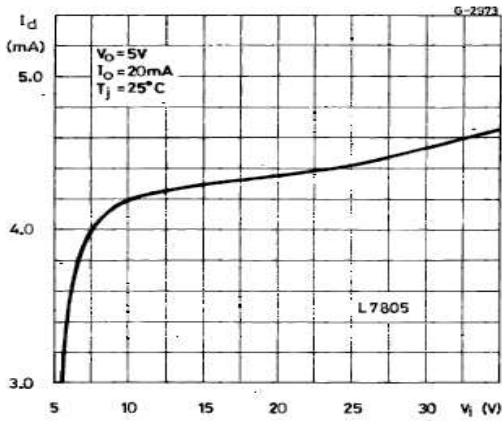

Figure 9:
Quiescent Current vs Input Voltage



OUTLINE DRAWING

TO-220 MECHANICAL DATA

DIM.	mm			inch		
	MIN.	TYP.	MAX.	MIN.	TYP.	MAX.
A	4.40		4.60	0.173		0.181
C	1.23		1.32	0.048		0.051
D	2.40		2.72	0.094		0.107
D1		1.27			0.050	
E	0.49		0.70	0.019		0.027
F	0.61		0.88	0.024		0.034
F1	1.14		1.70	0.044		0.067
F2	1.14		1.70	0.044		0.067
G	4.95		5.15	0.194		0.203
G1	2.4		2.7	0.094		0.106
H2	10.0		10.40	0.393		0.409
L2		16.4			0.645	
L4	13.0		14.0	0.511		0.551
L5	2.65		2.95	0.104		0.116
L6	15.25		15.75	0.600		0.620
L7	6.2		6.6	0.244		0.260
L9	3.5		3.93	0.137		0.154
DIA.	3.75		3.85	0.147		0.151

