

200mA Low Consumption Linear Regulator

DESCRIPTION

BL8060 series is a group of positive voltage output, low power consumption, low dropout voltage, three terminal regulator. It can provide 200mA output current when input / output voltage differential drops to 430mV ($V_{out}=2.8V$), The very low power consumption of BL8060 ($I_q=1.0\mu A$) can greatly improve natural life of batteries.

BL8060 can provide output value in the range of 1.1V~5.5V in 0.1V steps. It also can customized on command.

BL8060 includes high accuracy voltage reference, error amplifier, current limit circuit and output driver module.

BL8060 has well load transient response and good temperature characteristic, And it uses trimming technique to guarantee output voltage accuracy within $\pm 2\%$.

TYPICAL APPLICATION

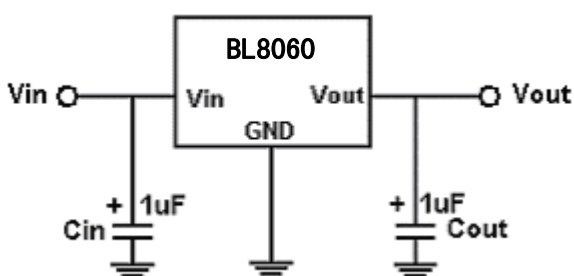

NOTE1:

Input capacitor ($C_{in}=1\mu F$) is recommended in all application circuit. Ceramic capacitor is recommended.

NOTE2:

Output capacitor ($C_{out}=1\mu F$) is recommended in all application to assure the stability of circuit. Ceramic capacitor is recommended.

FEATURES

- Low Power Consumption: $1.0\mu A$ (Typ.)
- Maximum Output Current: 200mA
- Small Dropout Voltage
 $210mV@100mA$ ($V_{out}=2.8V$)
 $430mV@200mA$ ($V_{out}=2.8V$)
- Input Voltage Range: 1.5V~14V
- Output Voltage Range: 1.1V~5.5V (customized on command in 0.1V steps)
- Highly Accurate: $\pm 2\%$ ($\pm 1\%$ customized)
- Output Current Limit

APPLICATIONS

- Battery Powered equipment
- Power Management of MP3、PDA、DSC、Mouse、PS2 Games
- Reference Voltage Source Regulation after Switching Power

ELECTRICAL CHARACTERISTICS

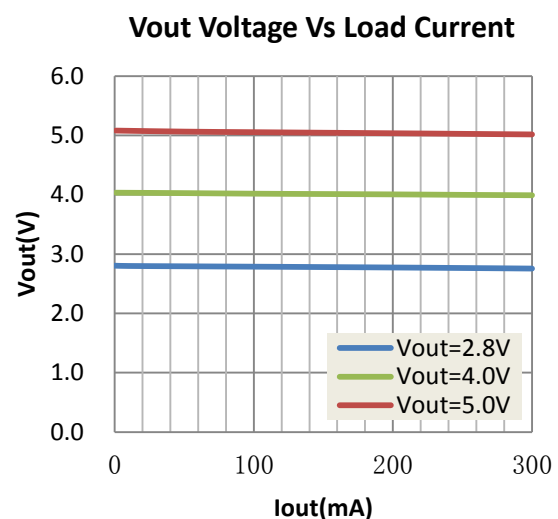

ORDERING INFORMATION

BL8060 ①②③④⑤

Code	Description
①	Temperature&Rohs: C:-40~85°C ,Pb Free Rohs Std.
②	Package type: B3:SOT-23-3 B5:SOT-23-5 C3:SOT-89-3 C3B:SOT-89-3 (B) HA:TO-92 HB:TO-92
③	Packing type: TR:Tape&Reel (Standard) BG:Bag (TO-92) PT:Reel (TO-92)
④	Output voltage: e.g. 11=1.1V 15=1.5V 55=5.5V
⑤	Voltage accuracy: 1=± 1% Blank(default)=± 2%

MARKING DESCRIPTON

N: Product Code

X: Output Voltage

Output Voltage Code

VOUT	Code	VOUT	Code	VOUT	Code
1.2V	2	3.0V	<u>0</u>	4.4V	<u>4</u>
1.3V	3	3.1V	<u>1</u>	4.5V	<u>5</u>
1.5V	5	3.2V	<u>2</u>	4.6V	<u>6</u>
1.8V	8	3.3V	<u>3</u>	4.7V	<u>7</u>
2.0V	<u>0</u>	3.4V	<u>4</u>	4.8V	<u>8</u>
2.1V	<u>1</u>	3.5V	<u>5</u>	4.9V	<u>9</u>
2.2V	<u>2</u>	3.6V	<u>6</u>	5.0V	<u>0</u>
2.3V	<u>3</u>	3.7V	<u>7</u>	5.1V	<u>1</u>
2.4V	<u>4</u>	3.8V	<u>8</u>	5.2V	<u>2</u>
2.5V	<u>5</u>	3.9V	<u>9</u>	5.3V	<u>3</u>
2.6V	<u>6</u>	4.0V	<u>0</u>	5.4V	<u>4</u>
2.7V	<u>7</u>	4.1V	<u>1</u>	5.5V	<u>5</u>
2.8V	<u>8</u>	4.2V	<u>2</u>		
2.9V	<u>9</u>	4.3V	<u>3</u>		

Y: The Year of manufacturing, "9" stands for year 2009,

"0" stands for year 2010, and "1" stands for year 2011.

W: The week of manufacturing. "A" stands for week

1, "Z" stands for week 26, "A" stands for week 27, "Z" stands for week 52.

PIN CONFIGURATION

Product Classification		BL8060CB3TR□ □ □
Marking		SOT-23-3
NXYWI	N:Product Code	<p>1 GND 2 Vout 3 Vin</p>
	X:Output Voltage	
	YW: Date Code	
Product Classification		BL8060CB5TR□ □ □
Marking		SOT-23-5
NXYWI	N: Product Code	<p>1 Vin 2 GND 3 IC 4 IC 5 Vout</p>
	X: Output Voltage	
	YW: Date Code	
Product Classification		BL8060CC3TR□ □ □
Marking		SOT-89-3
NXXI LLBYW	N:Product Code	<p>1 GND 2 Vin 3 Vout</p>
	XX:Output Voltage	
	LL:LOT NO.	
	B:FAB Code	
	YW:Date Code	
Product Classification		BL8060CC3BTR□ □ □
Marking		SOT-89-3
NXXIB LLBYW	N:Product Code	<p>1 Vout 2 GND 3 Vin</p>
	XX:Output Voltage	
	LL:LOT NO.	
	B:FAB Code	
	YW:Date Code	

Product Classification		BL8060CHABG□ □ □ BL8060CHAPT□ □ □
Marking		T0-92
NXXIA LLBYW	N:Product Code	<p>1 Vout 2 GND 3 Vin</p>
	XX:Output Voltage	
	LL:LOT NO.	
	B:FAB Code	
	YW:Date Code	
Product Classification		BL8060CHBBG□ □ □ BL8060CHBPT□ □ □
Marking		T0-92
NXXIB LLBYW	N:Product Code	<p>1 GND 2 Vin 3 Vout</p>
	XX:Output Voltage	
	LL:LOT NO.	
	B:FAB Code	
	YW:Date Code	
GND	Ground Pin	
Vin	Supply Voltage Input	
Vout	Output Voltage	

ABSOLUTE MAXIMUM RATING

Parameter		Value
Max Input Voltage		14V
Operating Junction Temperature(Tj)		125°C
Ambient Temperature(Ta)		-40°C -85°C
Power Dissipation	SOT-23-3	250mW
	SOT-23-5	250mW
	SOT-89-3	500mW
	TO-92	500mW
Storage Temperature(Ts)		-40°C -150°C
Lead Temperature & Time		260°C,10S

Note:

Exceed these limits to damage to the device.

Exposure to absolute maximum rating conditions may affect device reliability.

RECOMMENDED WORK CONDITIONS

Item	Min	Recommended	Max.	Unit
Input Voltage Range			12	V
Ambient Temperature	-40		85	°C

ELECTRICAL CHARACTERISTICS

(Test Conditions: Cin=1uF, Cout=1uF, TA=25°C, Unless Otherwise Specified)

Symbol	Parameter	Conditions	Min	Type	Max	Units
Vin	Input Voltage				12	V
Vout	Output Voltage		Vout x0.98		Vout X1.02	V
Iout(Max.)	Maximum Output Current	Vin-Vout=1V	200			mA
Dropout Voltage	Input-Output Voltage Differential	Iout=100mA	Vout ≤ 1.8V	600	1000	mV
			Vout ≥ 1.8V	300	600	
$\frac{\Delta V_{out}}{\Delta V_{in} \cdot V_{out}}$	Line Regulation	Iout=10mA 1.5V ≤ Vin ≤ 8V		0.2	0.3	%/V
ΔV_{out}	Load Regulation	Vin=Set Vout+1V 1mA ≤ Iout ≤ 100mA		20	40	mV
Iq	Quiescent Current	Vin=Set Vout+1V		1.0	5.0	uA
$\frac{\Delta V_{out}}{\Delta T \cdot V_{out}}$	Output Voltage Temperature Coefficient	Iout=10mA		100		ppm/°C

BLOCK DIAGRAM

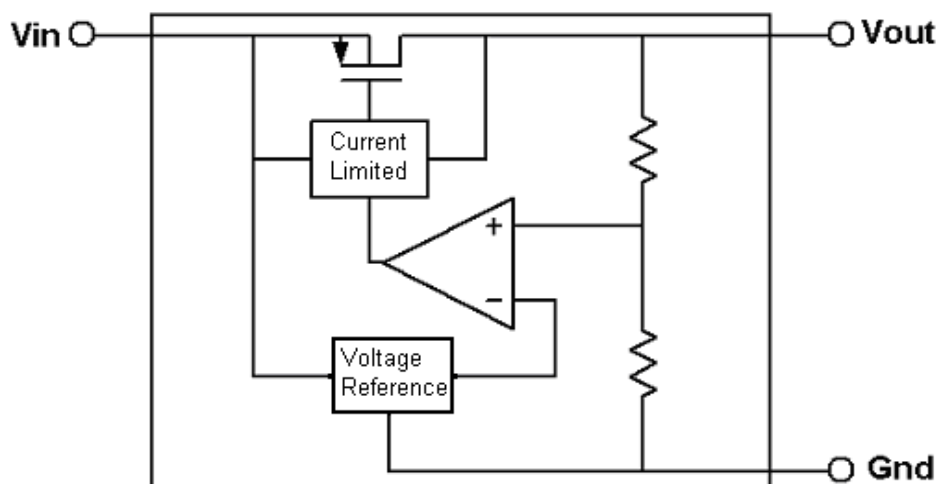

EXPLANATION

BL8060 is a series of low dropout voltage and low power consumption three pins regulator. Its application circuit is very simple, which only needs two outside capacitors. It is composed of these modules: high accuracy voltage reference, current limit circuit, error amplifier, output driver and power transistor.

Current Limit module can keep chip and power system away from danger when load current is more than 200mA.

BL8060 uses trimming technique to assure the accuracy of output value within $\pm 2\%$, at the same time, temperature compensation is elaborately considered in this chip, which makes BL8060's temperature coefficient within $100\text{ppm}/^\circ\text{C}$.

TYPICAL PERFORMANCE CHARACTERISTICS

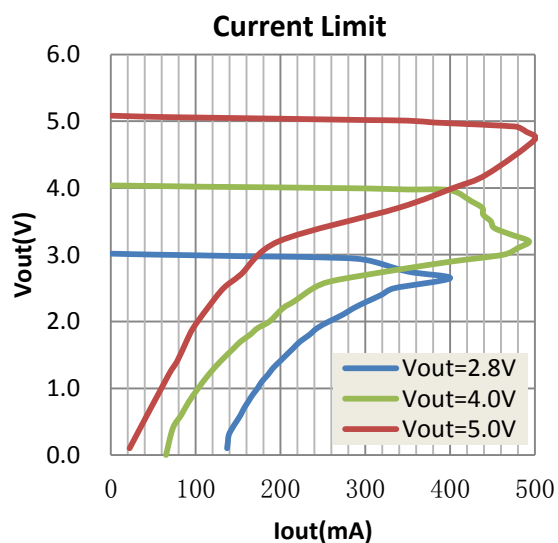
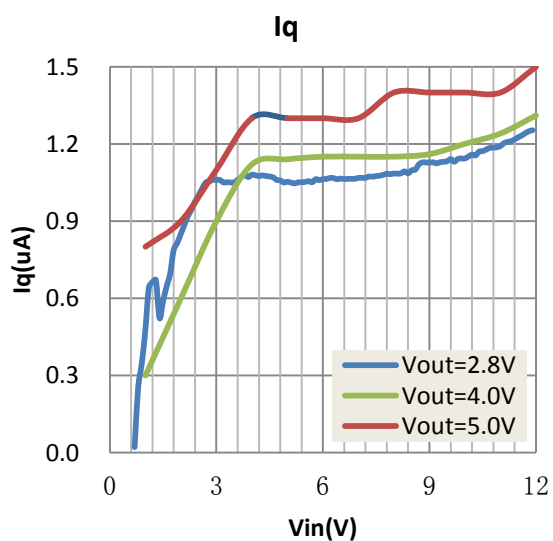
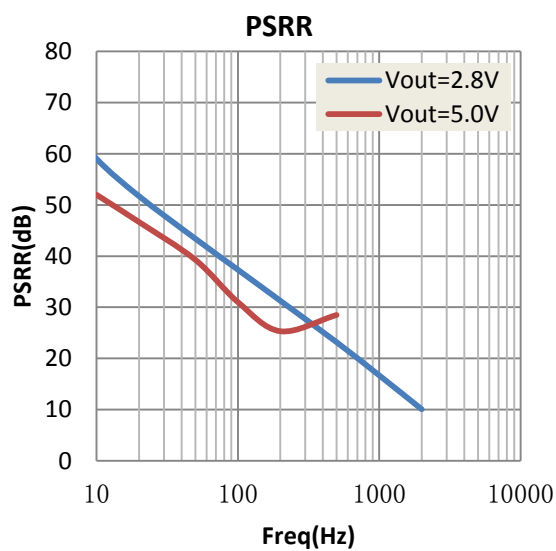
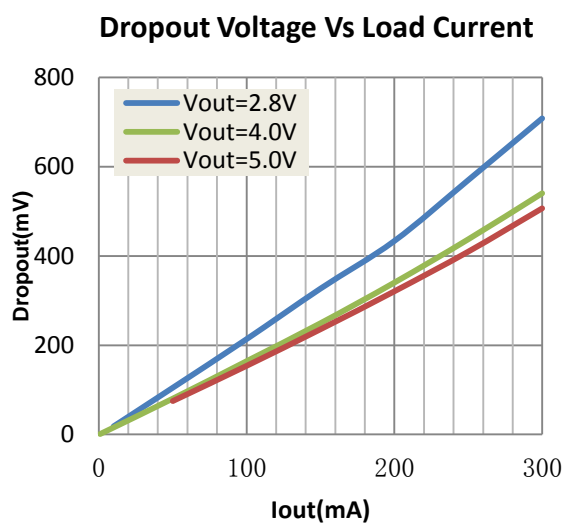
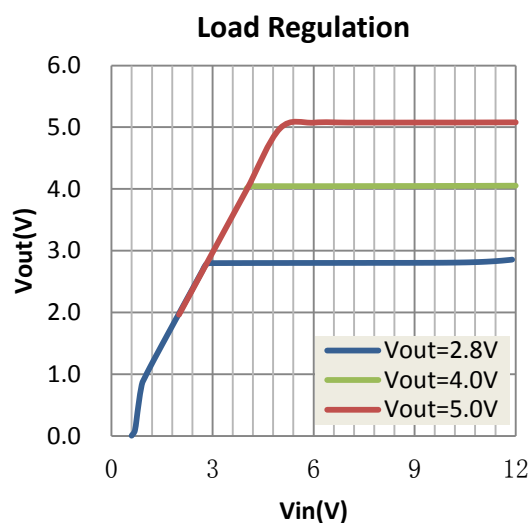
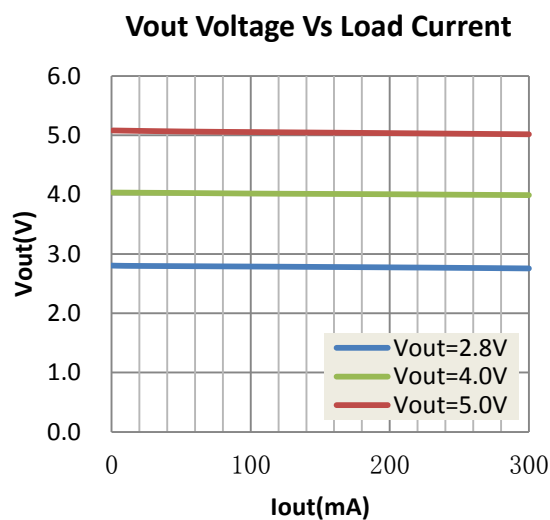

Line transient response

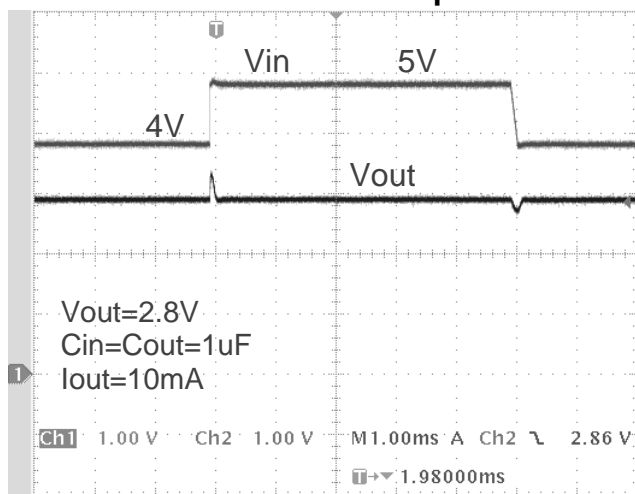

Load transient response

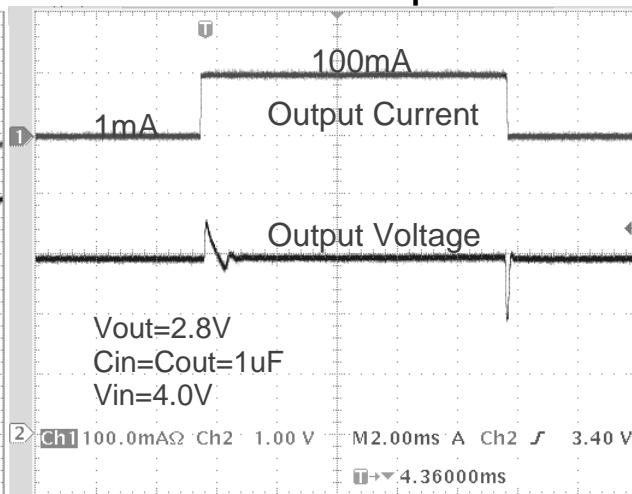

Start up

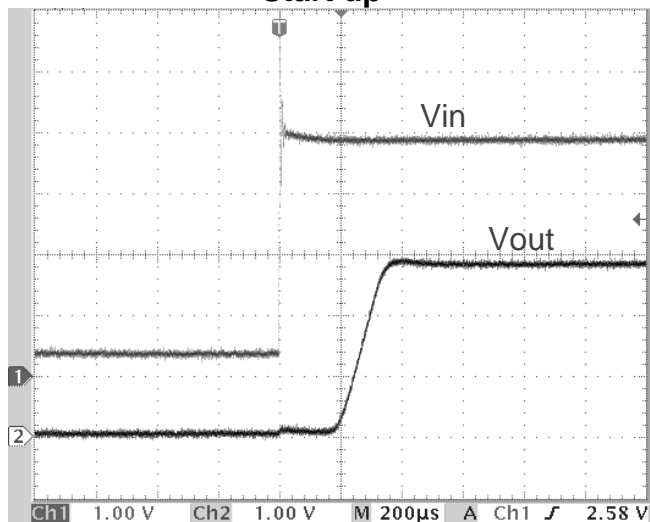

PACKAGE LINE

Package	SOT-23-3	Devices per reel	3000Pcs	Unit	mm
Package dimension:					
<p>Technical drawing of the SOT-23-3 package. The top view shows a rectangular body with a width of 2.9 ± 0.2 mm and a length of 1.9 ± 0.2 mm. The distance between the two bottom leads is 1.9 ± 0.2 mm, with each lead offset by 0.95 mm from the center. The top lead is 0.4 ± 0.1 mm wide and 0.8 mm long. The side view shows a maximum height of 1.4 mm, with a lead height of $1.1^{+0.2}_{-0.1}$ mm and a lead thickness of $0.16^{+0.1}_{-0.06}$ mm. The lead width is 0.2 mm minimum. The bottom view shows a perspective of the package with three leads labeled 1, 2, and 3.</p>					

Package	SOT-23-5	Devices per reel	3000Pcs	Unit	mm
Package Dimension:					
<p>Technical drawing of the SOT-23-5 package. The top view shows a rectangular body with a width of 2.9 ± 0.2 mm and a length of 1.9 ± 0.2 mm. The distance between the two bottom leads is 1.9 ± 0.2 mm, with each lead offset by 0.95 mm from the center. The top lead is 0.4 ± 0.1 mm wide and 0.8 ± 0.1 mm long. The side view shows a maximum height of 1.4 mm, with a lead height of $1.1^{+0.2}_{-0.1}$ mm and a lead thickness of $0.15^{+0.1}_{-0.05}$ mm. The lead width is 0.2 mm minimum. The bottom view shows a perspective of the package with five leads labeled 1, 2, 3, 4, and 5.</p>					

BL8060

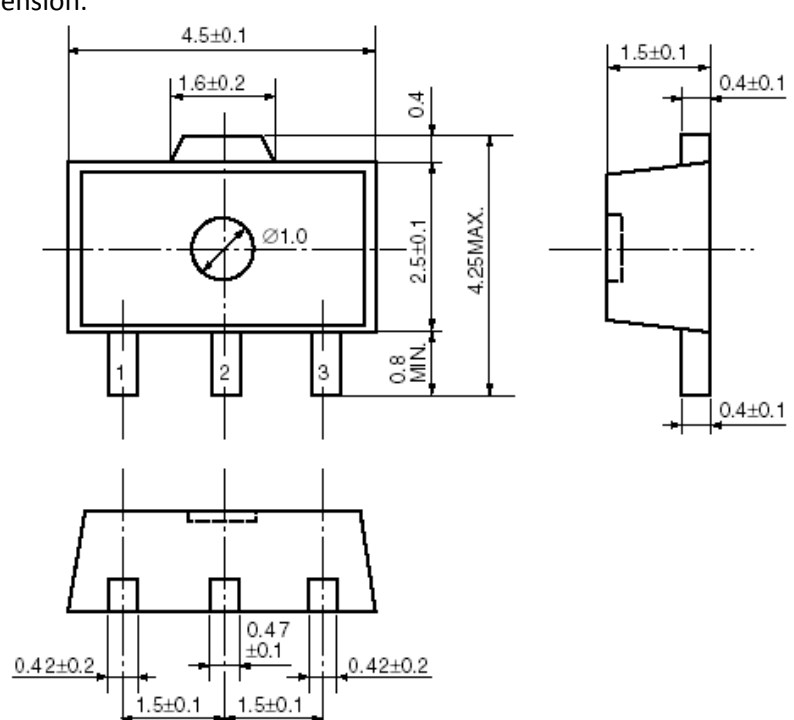
Package	SOT-89-3	Devices per reel	1000Pcs	Unit	mm
Package Dimension:					
 <p>The technical drawing illustrates the BL8060 SOT-89-3 package in three views: top, side, and bottom. The top view shows a rectangular package with a width of 4.5 ± 0.1 mm and a height of 2.5 ± 0.1 mm. A central circular feature has a diameter of $\varnothing 1.0$ mm. Three leads are attached to the bottom, with a minimum height of 0.8 mm. The side view shows a maximum height of 4.25 mm, with a lead height of 0.4 ± 0.1 mm. The bottom view shows a lead width of 1.5 ± 0.1 mm and a lead-to-lead spacing of 0.42 ± 0.2 mm. A central feature on the bottom has a width of 0.47 ± 0.1 mm.</p>					

BL8060

Package	TO-92	Devices per Bag	1000Pcs	Unit	mm
		Devices per reel	2000Pcs		

Package Dimension:

TO-92

