

4 PIN DIP PHOTOTRANSISTOR PHOTOCOUPLER

BL817 Series

FEATURES

- Current transfer ratio
(CTR: 50%-600% at $I_F=5\text{mA}$, $V_{CE}=5\text{V}$)
- High isolation voltage between inputc
and output (Viso=5000V rms)
- Creepage distance > 7.62mm
- Pb free and ROHS compliant
- UL/CUL Approved (File No. E340048)

Description

The BL817 series of devices each consist of an infrared Emitting diodes, optically coupled to a phototransistor detector. They are packaged in a 4-pin DIP package and available in Wide-lead spacing and SMD option.

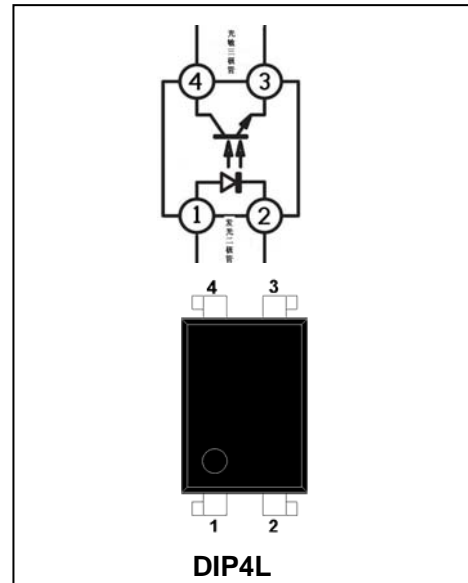

APPLICATIONS

- Programmable controllers
- System appliances, measuring instruments
- Telecommunication equipments
- Home appliances, such as fan heaters, etc
- Signal transmission between circuits of different potentials And impedances

4 PIN DIP PHOTOTRANSISTOR PHOTOCOUPLER **BL817 Series**

MAXIMUM RATING @ Ta=25°C unless otherwise specified

Parameter		Symbol	Rating	Unit
Input	Forward current	I_F	50	mA
	Peak forward Current (Note 1)	I_{FM}	1	A
	Reverse Voltage	V_R	6	V
	Power dissipation	P	70	mW
Output	Collector-Emitter voltage	V_{CEO}	80	V
	Emitter- Collector voltage	V_{ECO}	6	V
	Collector Current	I_c	50	mA
	Collector Power dissipation	P_C	150	mW
Total Power dissipation		P_{tot}	200	mW
Isolation voltage (Note 2)		V_{iso}	5000	V rms
Rated impulse isolation voltage		V_{IOTM}	6000	V
Rated repetitive peak isolation voltage		V_{IORM}	630	V
Thermal resistance, junction to ambient air		$R_{\theta JA}$	430	°C/W
Thermal Resistance Junction-to-Case		$R_{\theta JC}$	350	°C/W
Operating temperature		T_{opr}	-30~+100	°C
Storage temperature		T_{stg}	-55~+125	°C
Soldering temperature (Note 3)		T_{sol}	260	°C

Note 1: Pulse width ≤ 1μs, Duty ratio : 0.001

2: 40 to 60% RH, AC for 1 minute

3: For 10 seconds

4 PIN DIP PHOTOTRANSISTOR PHOTOCOUPLER **BL817 Series**

ELECTRICAL CHARACTERISTICS @ Ta=25°C unless otherwise specified

Parameter		Symbol	Condition	Min.	Typ.	Max.	Unit
INPUT	Forward voltage	V_F	$I_F=20mA$	-	1.2	1.4	V
	Peak forward voltage	V_{FM}	$I_{FM}=0.5A$	-	-	3.0	V
	Reverse Current	I_R	$V_R=4V$	-	-	10	μA
	Terminal capacitance	C_t	$V=0, f=1KHz$	-	30	250	pF
OUTPUT	Collector Dark Current	I_{CEO}	$V_{CE}=20V, I_F=0$	-	-	100	nA
	Collector-Emitter breakdown voltage	BV_{CEO}	$I_C=0.1mA, I_F=0$	80	-	-	V
	Emitter-Collector breakdown voltage	BV_{ECO}	$I_E=10\mu A, I_F=0$	6	-	-	V
TRANSFER CHARACTERISTICS	Collector Current	I_C	$I_F=5mA,$ $V_{CE}=5V$	2.5	-	30	mA
	Current Transfer ratio (Note 4)	CTR		50	-	600	%
	Collector-emitter saturation voltage	$V_{CE(Sat)}$	$I_F=20mA$ $I_C=1mA$	-	0.1	0.2	V
	Isolation resistance	R_{iso}	DC500V, 40~60%R.H	5×10^{10}	1×10^{11}	-	Ω
	Floating capacitance	C_f	$V=0, f=1MHz$	-	0.6	1	pF
	Cut-off frequency	f_c	$V_{CE}=5V, I_C=2mA,$ $R_L=100\Omega, -3dB$	-	80	-	kHz
	Rise time	T_r	$V_{CE}=2V$ $I_C=2mA$	-	4	18	μs
Fall Time	T_f	$R_L=100\Omega$	-	3	18	μs	

Rank Table of Current Transfer Ratio CTR

Rank Mark	Min.(%)	Max.(%)
L	50	100
A	80	160
B	130	260
C	200	400
D	300	600
L or A or B or C or D	50	600

Note 4: Classification table of current transfer ratio is shown below.

4 PIN DIP PHOTOTRANSISTOR PHOTOCOUPLER BL817 Series

TYPICAL CHARACTERISTICS @ $T_a=25^{\circ}\text{C}$ unless otherwise specified

Fig.1 Forward Current vs. Ambient Temperature

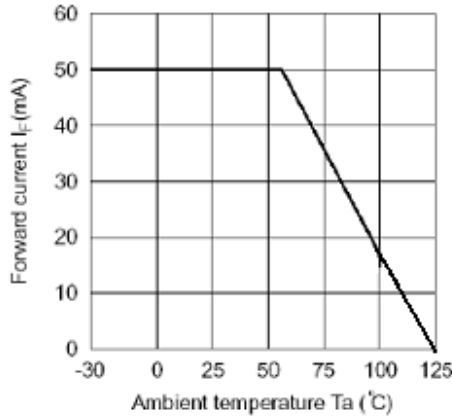

Fig.2 Collector Power Dissipation vs. Ambient Temperature

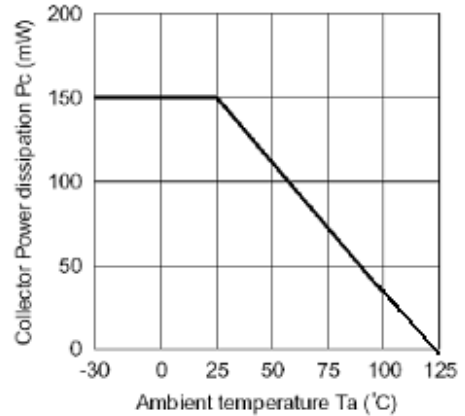

Fig.3 Collector-emitter Saturation Voltage vs. Forward Current

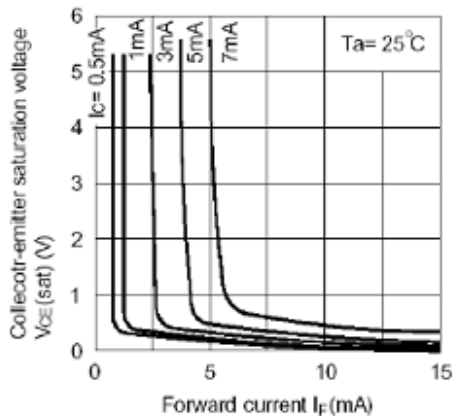

Fig.4 Forward Current vs. Forward Voltage

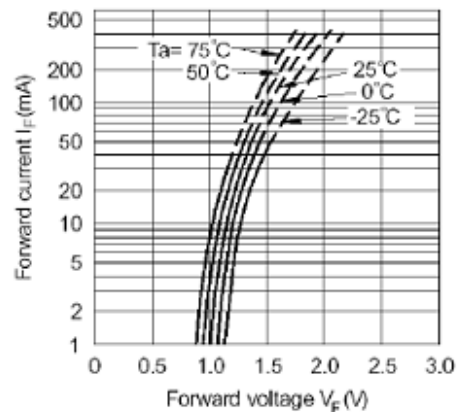

Fig.5 Current Transfer Ratio vs. Forward Current

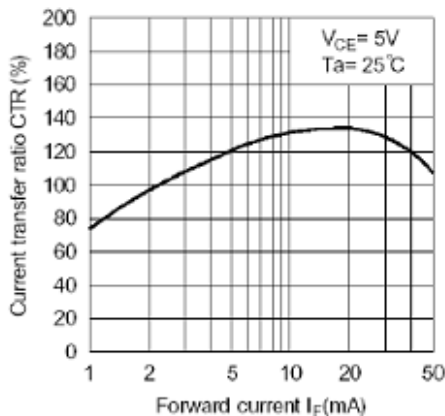
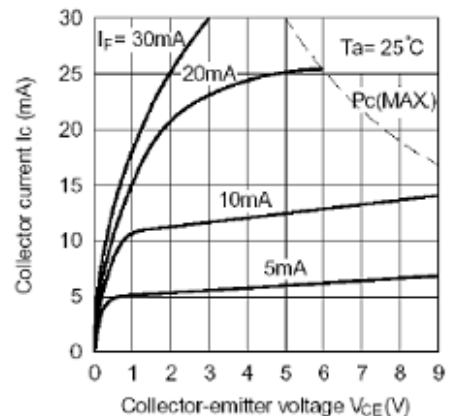

Fig.6 Collector Current vs. Collector-emitter Voltage



4 PIN DIP PHOTOTRANSISTOR PHOTOCOUPLER BL817 Series

Fig.7 Relative Current Transfer Ratio vs. Ambient Temperature

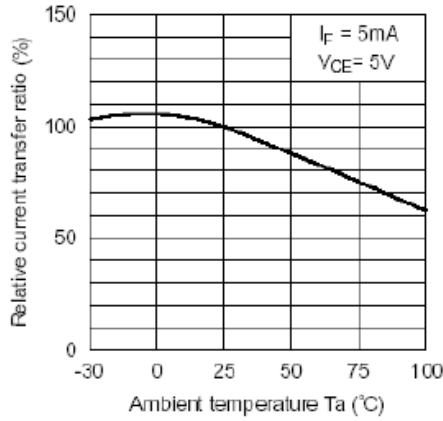

Fig.8 Collector-emitter Saturation Voltage vs. Ambient Temperature

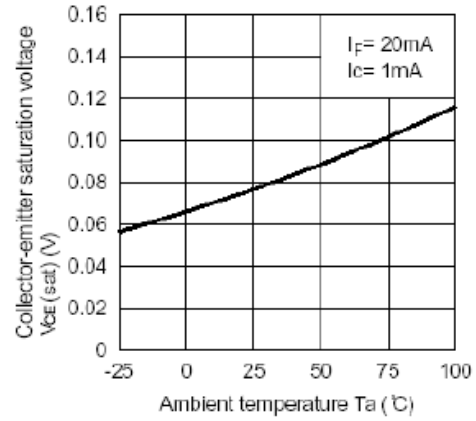

Fig.9 Collector Dark Current vs. Ambient Temperature

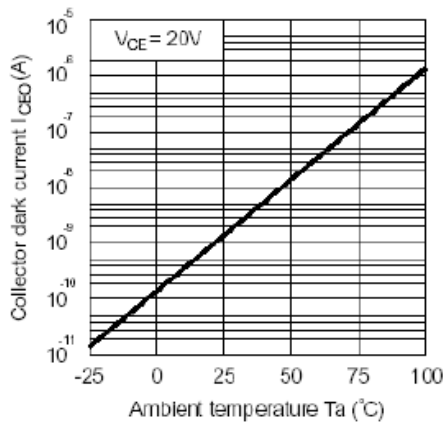

Fig.10 Response Time vs. Load Resistance

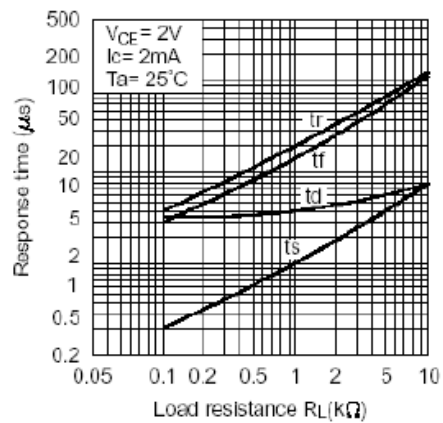
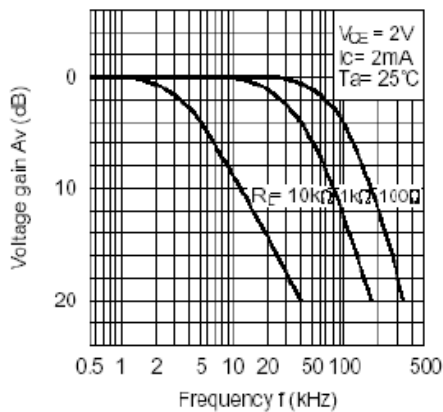
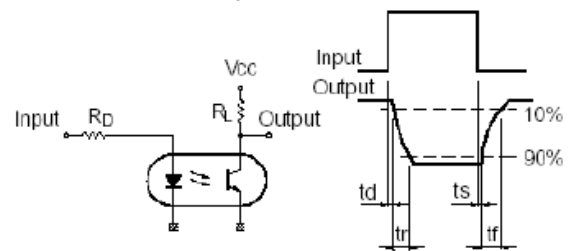

Fig.11 Frequency Response



Test Circuit for Response Time



Test Circuit for Frequency Response

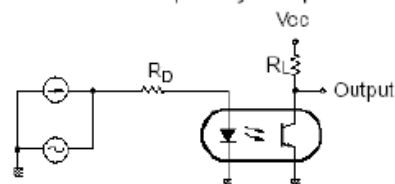

4 PIN DIP PHOTOTRANSISTOR PHOTOCOUPLER **BL817 Series**

Package Dimensions (All Dimensions in mm)

BL817

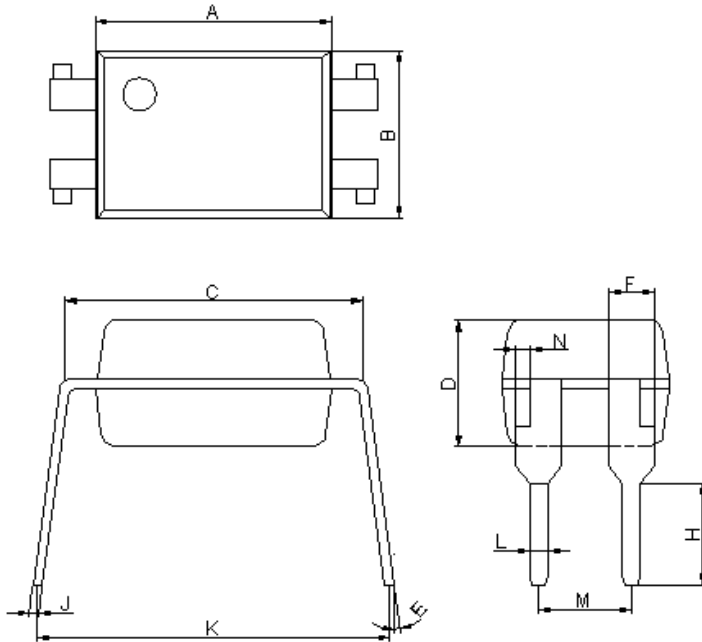

Dim	Min	Max
A	6.40	6.60
B	4.50	4.70
C	7.90	8.30
D	3.28	3.68
E	2°	8°
F	1.15	1.35
H	2.70	2.90
J	0.20	0.30
K	8.86	9.31
L	0.40	0.60
M	2.44	2.64
N	0.30	0.50

BL817S

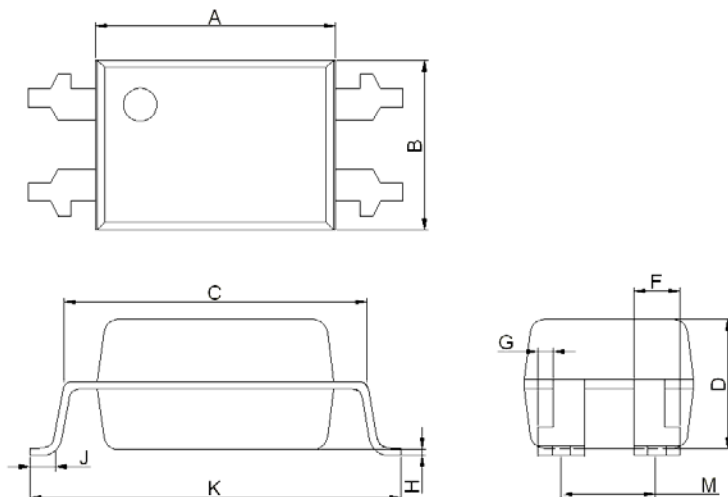

Dim	Min	Max
A	6.40	6.60
B	4.50	4.70
C	7.90	8.30
D	3.28	3.68
F	1.15	1.35
G	0.30	0.50
H	0.00	0.20
J	0.9	1.2
K	9.80	10.30
M	2.49	2.69

4 PIN DIP PHOTOTRANSISTOR PHOTOCOUPLER **BL817 Series**

BL817M

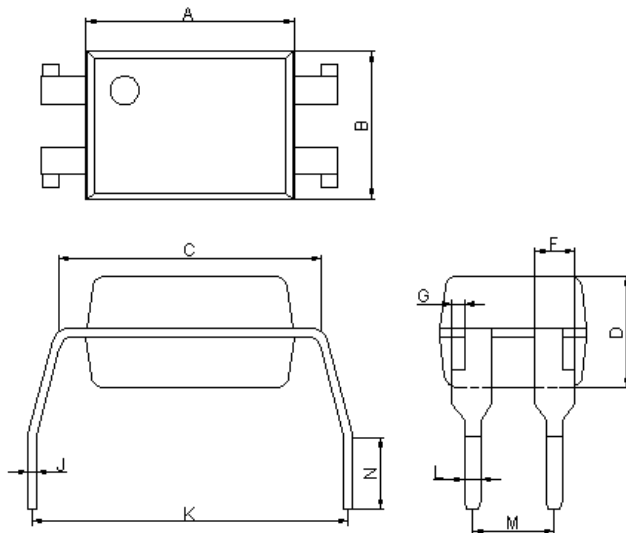

Dim	Min	Max
A	6.40	6.60
B	4.50	4.70
C	7.90	8.30
D	3.28	3.68
F	1.15	1.35
G	0.30	0.50
J	0.20	0.30
K	9.86	10.46
L	0.40	0.60
M	2.44	2.64
N	2.4	2.9

Ordering Information

Part Number	Package	Application part number
BL817	4-pin DIP	BL817
BL817S	4-pin (tape and reel packaging)	
BL817M	4-pin (leads with 0.4" spacing)	

SOLDERING FOOTPRINT

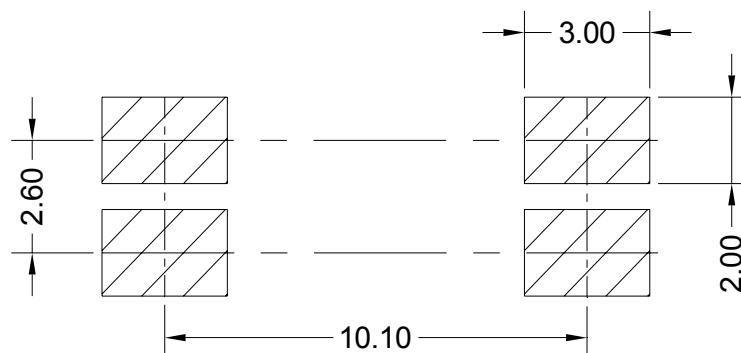

UNIT:mm