

High Efficiency Low Noise PFM Step-up DC/DC Converter

DESCRIPTION

BL8531 series are CMOS-based PFM step-up DC-DC Converter. The converter can start up by supply voltage as low as 0.8V, and capable of delivering maximum 200mA output current at 3.3V output with 1.8V input Voltage. Quiescent current drawn from power source is as low as 5.5uA. All of these features make BL8531 series be suitable for the portable devices, which are supplied by a single battery to four-cell batteries.

To reduce the noise caused by the switch regulator, BL8531 is well considerate in circuit design and manufacture. So that the interferer to other circuits by the device is reduced greatly.

BL8531 integrates stable reference circuits and trimming technology, so it can afford high precision and low temperature-drift coefficient of the output voltage.

BL8531 is available in SOT-89-3, SOT-23-3, SOT-23-5 and TO-92 packages, which is PB free. And in 5-pin packages, such as SOT-23-5, the device can be switch on or off easily by CE pin, to minimize the standby supply current.

TYPICAL APPLICATION

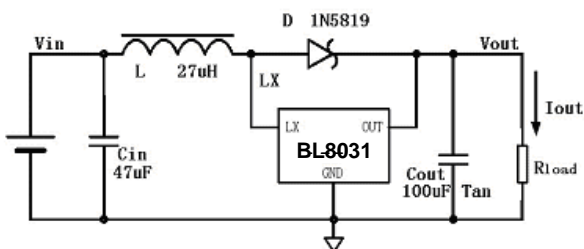

FEATURES

- Deliver 200mA at 3.3V Output voltage with 1.8V input Voltage
- Low start-up voltage (when the output current is 1mA)-----0.8V
- Output voltage can be adjusted from 2.5V~6.0V (In 0.1V step)
- Output voltage accuracy ----- $\pm 2\%$
- Low temperature-drift coefficient of the output voltage----- $\pm 100\text{ppm}/^\circ\text{C}$
- Only three external components are necessary: An inductor, a Schottky diode and an output filter capacitor
- High power conversion efficiency-----85%
- Low quiescent current drawn from power source----- $< 5.5\mu\text{A}$

APPLICATIONS

- Power Source for PDA, DSC, MP3 Player, Electronic toy and wireless mouse
- Power Source for a Single or Dual-cell Battery-Powered Equipments
- Power Source for LED

ELECTRICAL CHARACTERISTICS

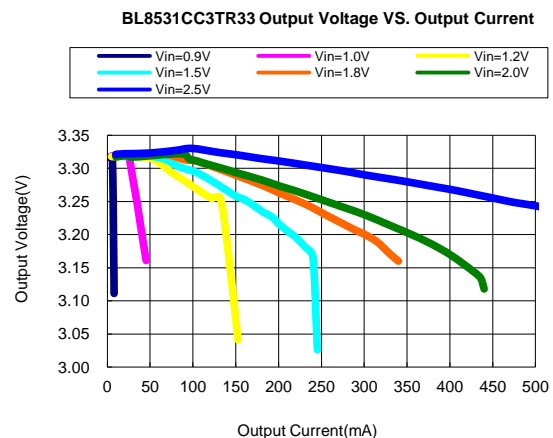

ORDERING INFORMATION

BL8531 ① ② ③ ④

Code	Description
①	Temperature&RoHS: C: -40~85°C, Pb Free RoHS Std.
②	Package type: B3: SOT-23-3 B5: SOT-23-5 C3: SOT-89-3 H: TO-92
③	Packing type: TR: Tape&Reel (Standard) BG: Bag (TO-92)
④	Output voltage: e.g. 25=2.5V 33=3.3V 60=6.0V

ABSOLUTE MAXIMUM RATING

Parameter	Value	
Input Voltage Range	-0.3V-12V	
Input Voltage	-0.3V-(Vout+0.3)	
CE Pin Voltage	-0.3V-(Vout+0.3)	
Lx Pin Output Current	0.7A	
Operating Junction Temperature (Tj)	125°C	
Ambient Temperature (Ta)	-40°C -85°C	
Power Dissipation	SOT-23-3	250mW
	SOT-23-5	250mW
	SOT-89-3	500mW
	TO-92	500mW
Storage Temperature (Ts)	-40°C -150°C	
Lead Temperature & Time	260°C, 10S	

Note:



Exceed these limits to damage to the device.

Exposure to absolute maximum rating conditions may affect device reliability.

PIN CONFIGURATION

CE	Chip Enable (Active high)
GND	Ground
OUT	Output Feedback Pin, Power supply for internal
LX	Switching Pin
NC	No Connection

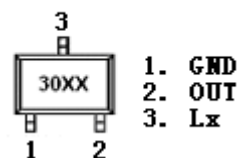
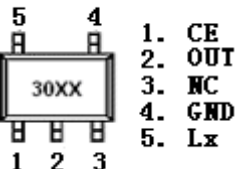
MARKING INFORMATION

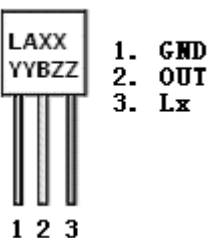
Product Classification		BL8531CB3TR□ □
Marking		SOT-23-3
30XX	30:Product Code	
	XX: Output Voltage	
Product Classification		BL8531CB5TR□ □
Marking		SOT-23-5
30XX	30:Product Code	
	XX: Output Voltage	
Product Classification		BL8531CC3TR□ □
Marking		SOT-89-3
LAXX YYBZZ	LA: Product Code	
	XX: Output Voltage	
	YY: LOT NO.	
	B: FAB Code	
		ZZ: Date Code
Product Classification		BL8531CHBG□ □
Marking		TO-92
LAXX YYBZZ	LA: Product Code	
	XX: Output Voltage	
	YY: LOT NO.	
	B: FAB Code	
		ZZ: Date Code

RECOMMENDED WORK CONDITIONS

Item	Min	Recommended	Max.	Unit
Input Voltage Range	0.8		Vout	V
Inductor	10	27	100	μH
Input Capacitor	0	≥10		μF
Output Capacitor	47	100	220	μF
Ambient Temperature	-40		85	°C

ELECTRICAL CHARACTERISTICS

SYMBOL	ITEM	TEST CONDITIONS	REFERENCE DATA			UNIT
			Min	Typ	Max	
Vout	Output Voltage		2.45	2.5	2.55	V
			2.646	2.7	2.754	
			2.94	3.0	3.06	
			3.234	3.3	3.366	
			3.528	3.6	3.672	
			3.92	4.0	4.08	
			4.9	5.0	5.1	
			5.88	6.0	6.12	
Vin	Input Voltage			12	V	
Iin	Input Current	Iout=0mA, Vin=Vout*0.6		12	15	uA
Vstart	Start-up voltage	Iout=1mA, Vin: 0→2V		0.8	0.9	V
Vhold	Hold-on voltage	Iout=1mA, Vin: 2→0V	0.6	0.7		V
IDD	Quiescent current drawn from power source	Without external components, Vout =Vout×1.05		4	7	uA
Rswon	Switch ON Resistance			0.4	0.5	Ω
ILXleak	LX leakage current	Vout=Vlx=6V		0.5	5	uA
VCEH	CE "H" threshold voltage	VCE: 0→2V	0.8			V
VCEL	CE "H" threshold voltage	VCE: 2→0V			0.3	V
Fosc	Oscillator frequency	LX on "L" side Vout=Vout*0.96		400		KhZ
Maxdty	Oscillator duty cycle	On (Vlx"L") side	70	75	80	%
η	Efficiency			85		%

Note:

1. Diode: Schottky type, such as: 1N5817, 1N5819, 1N5822
2. Inductor: 27uH(R<0.5Ω)
3. Capacitor: 100uF(Tantalum type)

BLOCK DIAGRAM

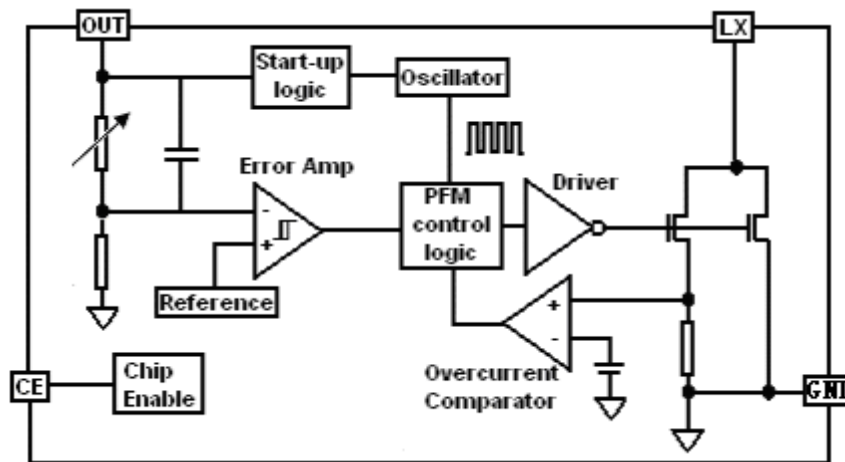

Note: CE pin is only available on 5 pins packages.

DETAILED DESCRIPTION

The BL8531 series are boost structure, voltage-type Pulse-Frequency Modulation (PFM) step-up DC-DC converter. Only three external components are necessary: an inductor, an output filter capacitor and a schottky diode. And the converter's low noise and low ripple output voltage can be adjusted from 2.5V to 5.0V, 0.1V step. By using the depletion technics, the quiescent current drawn from power source is lower than 7uA. The high efficiency device consists of resistors for output voltage detection and trimming, a start-up voltage circuit, an oscillator, a reference circuit, a PFM control circuit, a switch protection circuit and a driver transistor.

The PFM control circuit is the core of the BL8531 IC. This block controls power switch on duty cycle to stabilize output voltage by calculating results of other blocks which sense input voltage, output voltage, output current and load conditions. In PFM modulation system, the frequency and pulse width is fixed. The duty cycle is adjusted by skipping pulses, so that switch on-time is changed based on the conditions such as input voltage, output current and load. The oscillate block

inside BL8531 provides fixed frequency and pulse width wave.

The reference circuit provides stable reference voltage to output stable output voltage. Because internal trimming technology is used, The chip output change less than $\pm 2\%$. At the same time, the problem of temperature-drift coefficient of output voltage is considered in design, so temperature-drift coefficient of output voltage is less than 100ppm/ $^{\circ}\text{C}$.

High-gain differential error amplifier guarantees stable output voltage at difference input voltage and load. In order to reduce ripple and noise, the error amplifier is designed with high band-with.

Though at very low load condition, the quiescent current of chip do effect efficiency certainly. The four main energy loss of Boost structure DC-DC converter in full load are the ESR of inductor, the voltage of Schottky diode, on resistor of internal N-channel MOSFET and its driver. In order to improve the efficiency, BL8531 integrates low on-resistor N-channel MOSFET and well design driver circuits. The switch energy loss is limited at very low level.

SELECTION THE EXTERNAL COMPONENTS

Thus it can be seen, the inductor and schottky diode affect the conversion efficiency greatly. The inductor and the capacitor also have great influence on the output voltage ripple of the converter. So it is necessary to choose a suitable inductor, a capacitor and a right schottky diode, to obtain high efficiency, low ripple and low noise. Before discussion, we define

$$D \equiv \frac{V_{out} - V_{in}}{V_{out}}$$

INDUCTOR SELECTION

Above all, we should define the minimum value of the inductor that can ensure the boost DC-DC to operate in the continuous current-mode condition.

$$L_{min} \geq \frac{D(1-D)^2 R_L}{2f}$$

The above expression is got under conditions of continuous current mode, neglect Schottky diode's voltage, ESR of both inductor and capacitor. The actual value is greater than it. If inductor's value is less than L_{min} , the efficiency of DC-DC converter will drop greatly, and the DC-DC circuit will not be stable.

Secondly, consider the ripple of the output voltage,

$$\Delta I = \frac{D \cdot V_{in}}{Lf}$$

$$I_{max} = \frac{V_{in}}{(1-D)^2 R_L} + \frac{DV_{in}}{2Lf}$$

If inductor value is too small, the current ripple through it will be great. Then the current through diode and power switch will be great. Because the power switch on chip is not ideal switch, the energy of switch will improve. The efficiency will fall.

Thirdly, in general, smaller inductor values supply more output current while larger values start up with lower input voltage and acquire high efficiency.

An inductor value of 3uH to 1mH works well in most applications. If DC-DC converter delivers large output current (for example: output current is great than 50mA), large inductor value is recommended in order to improve efficiency. If DC-DC must output very large current at low input supply voltage, small inductor value is recommended.

The ESR of inductor will affect efficiency greatly. Suppose ESR value of inductor is r_L , R_{load} is load resistor, then the energy can be calculated by following expression:

$$\Delta \eta \approx \frac{r_L}{R_{load}(1-D)^2}$$

For example: input 1.5V, output is 3.0V, $R_{load}=20\Omega$, $r_L=0.5\Omega$, The energy loss is 10%.

Consider all above, inductor value of 47uH、ESR<0.5Ω is recommended in most applications. Large value is recommended in high efficiency applications and smaller value is recommended.

CAPACITOR SELECTION

Ignore ESR of capacitor, the ripple of output voltage is:

$$r = \frac{\Delta V_{out}}{V_{out}} = \frac{D}{R_{load}Cf}$$

So large value capacitor is needed to reduce ripple. But too large capacitor value will slow down system reaction and cost will improve. So 100uF capacitor is recommended. Larger capacitor value will be used in large output current system. If output current is small (<10mA), small value is needed.

Consider ESR of capacitor, ripple will increase:

$$r' = r + \frac{I_{max} \cdot R_{ESR}}{V_{out}}$$

When current is large, ripple caused by ESR will be main factor. It may be greater than 100mV. The ESR will affects efficiency and increase energy loss. So low-ESR capacitor (for example: tantalum capacitor) is recommend or connect two or more filter capacitors in parallel.

DIODE SELECTION

Rectifier diode will affect efficiency greatly, Though a common diode (such as 1N4148) will work well for light load, it will reduce about 5%~10% efficiency for heavy load, For optimum performance, a Schottky diode (such as 1N5817、1N5819、1N5822) is recommended.

INPUT CAPACITOR

If supply voltage is stable, the DC-DC circuit can output low ripple, low noise and stable voltage without input capacitor. If voltage source is far away from DC-DC circuit, input capacitor value greater than 10uF is recommended.

TEST CIRCUITS

Output voltage test circuit
($I_{load}=1mA$)

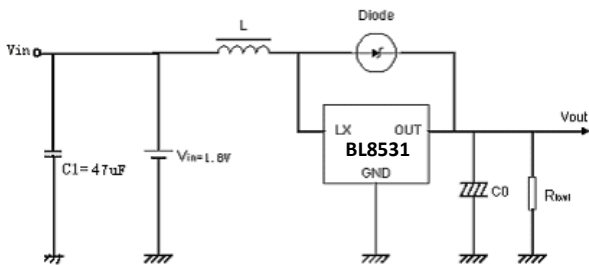

Quiescent current test circuit
($V_{out}=V_{out_nom} * 1.05$, $R=1K\Omega$, $C=0.1uF$)

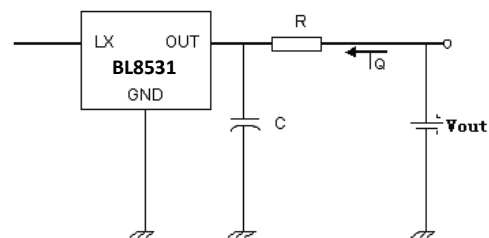

Start-up voltage test circuit
($I_{load}=1mA$)

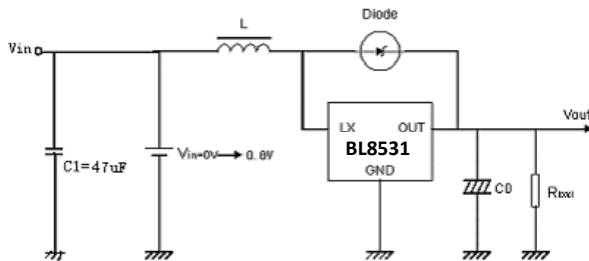

Oscillator frequency and duty cycle test circuit
($V_{in}=V_{out} * 0.95$, $R=1K\Omega$)

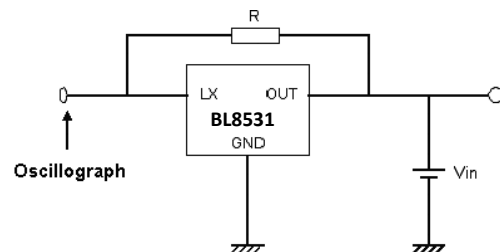

Hold-on voltage test circuit
($I_{load}=1mA$)

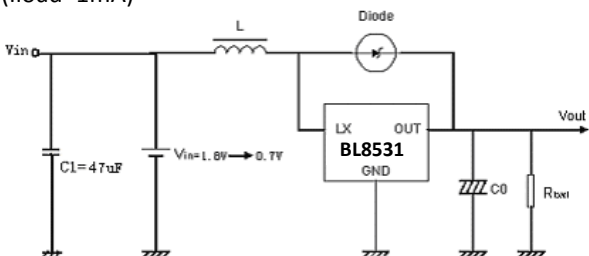

TYPICAL PERFORMANCE CHARACTERISTICS

Recommended operating conditions: $C_{in}=47\mu F$, $C_{out}=47\mu F$, $T_{opt}=25^{\circ}C$. unless otherwise noted)

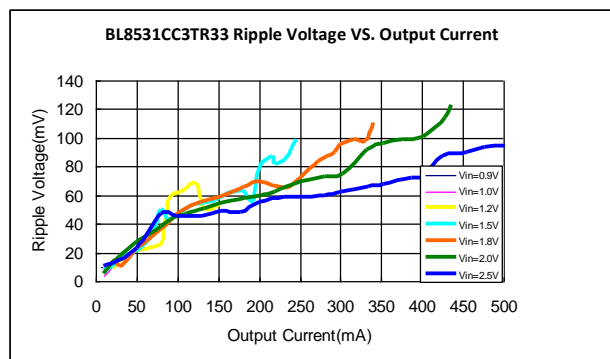
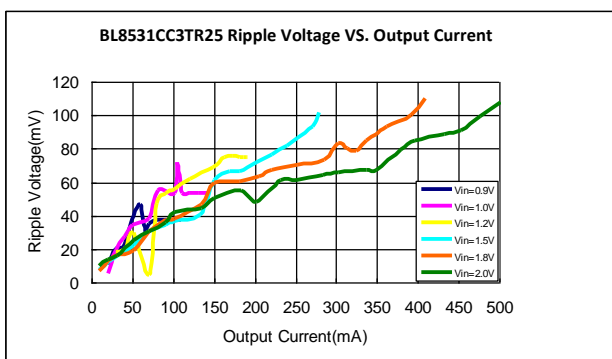
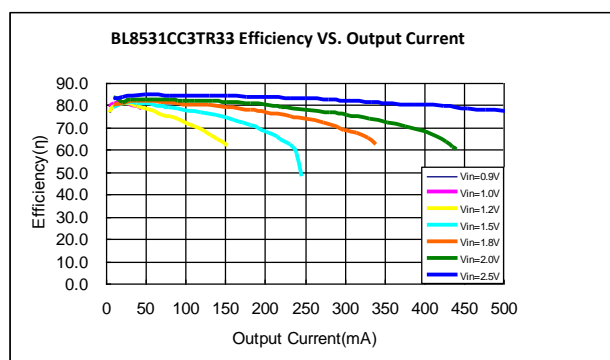
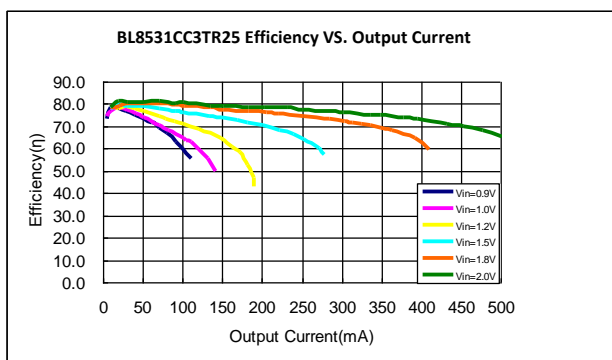
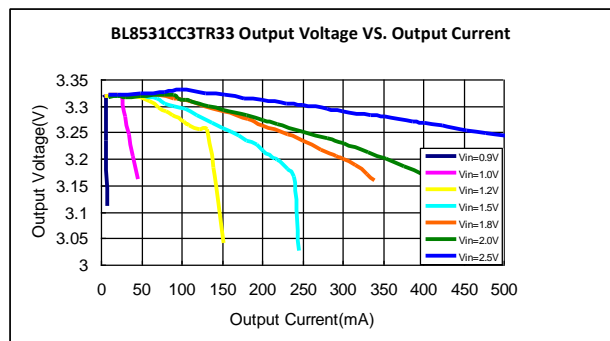
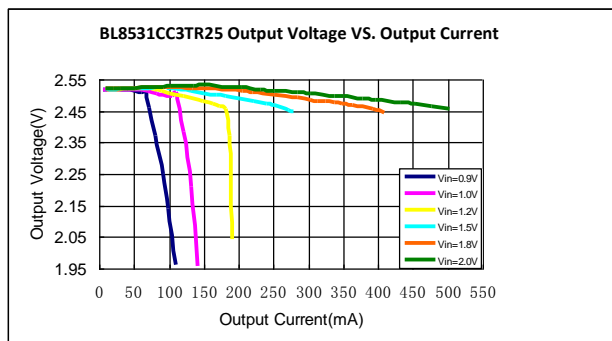

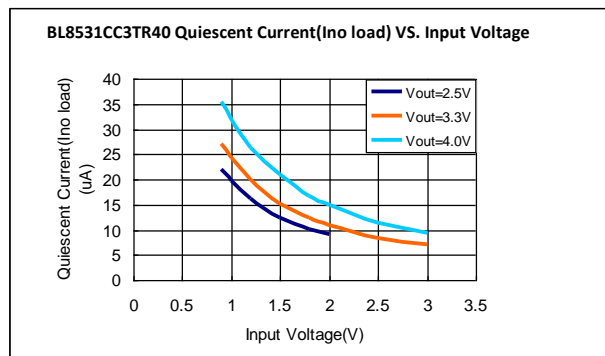
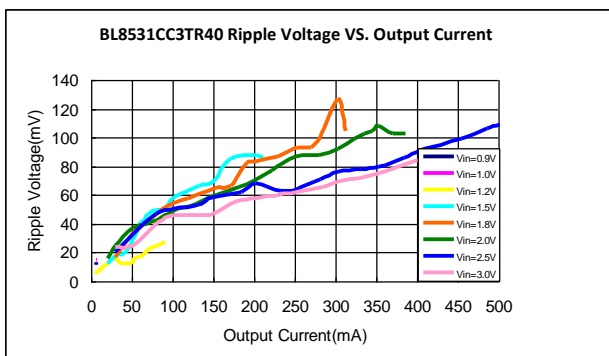
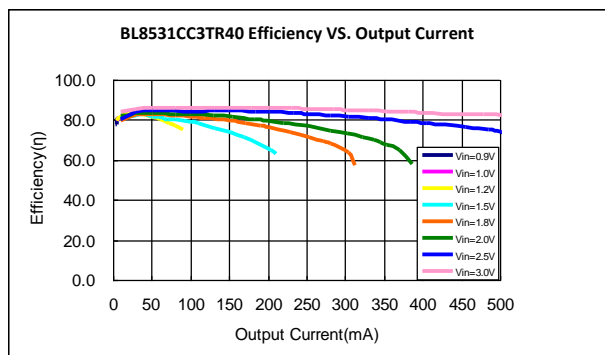
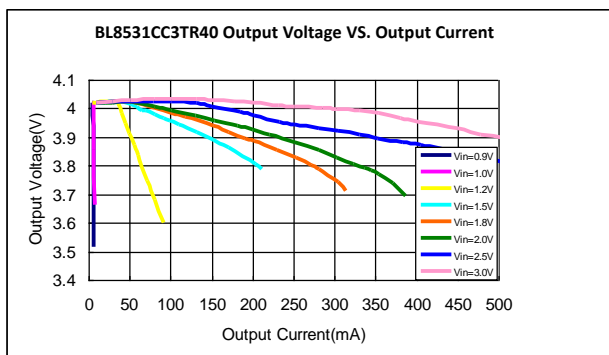

PACKAGE OUTLINE

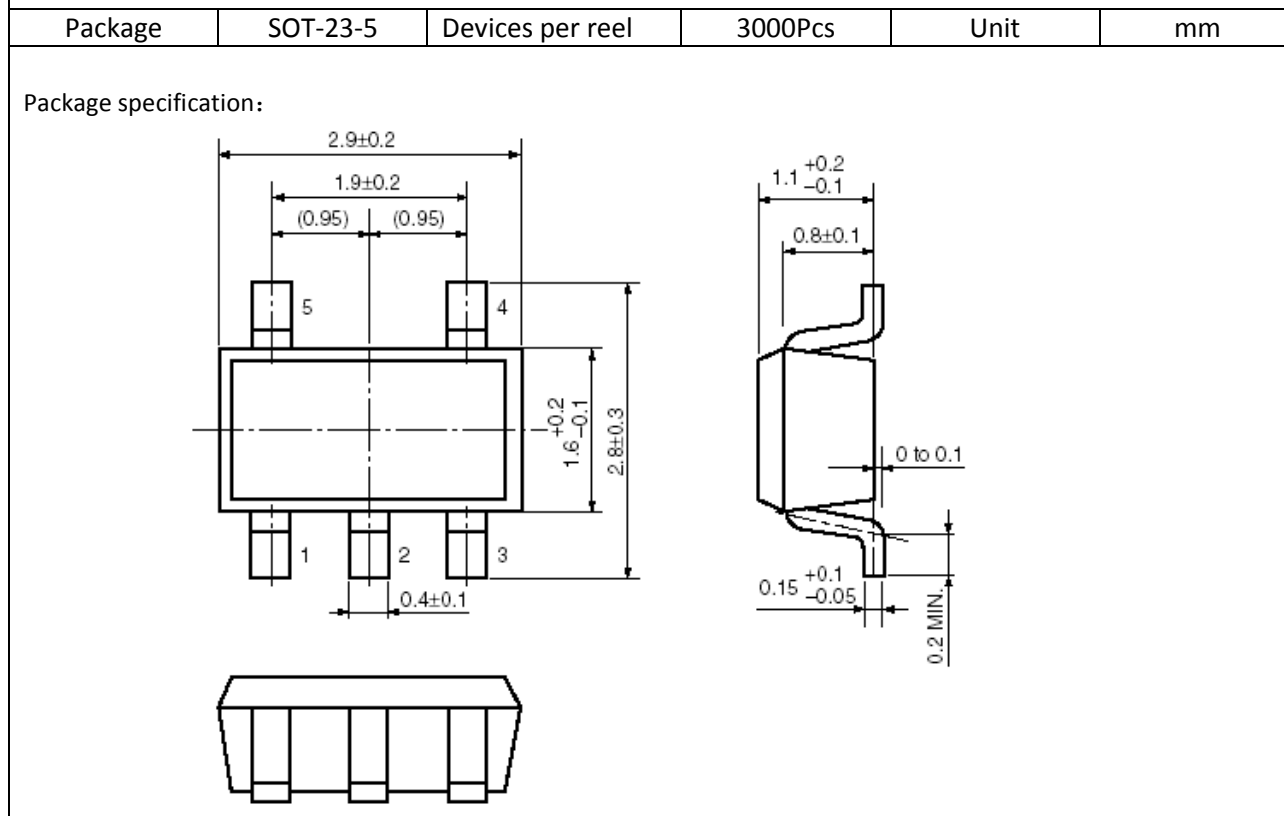
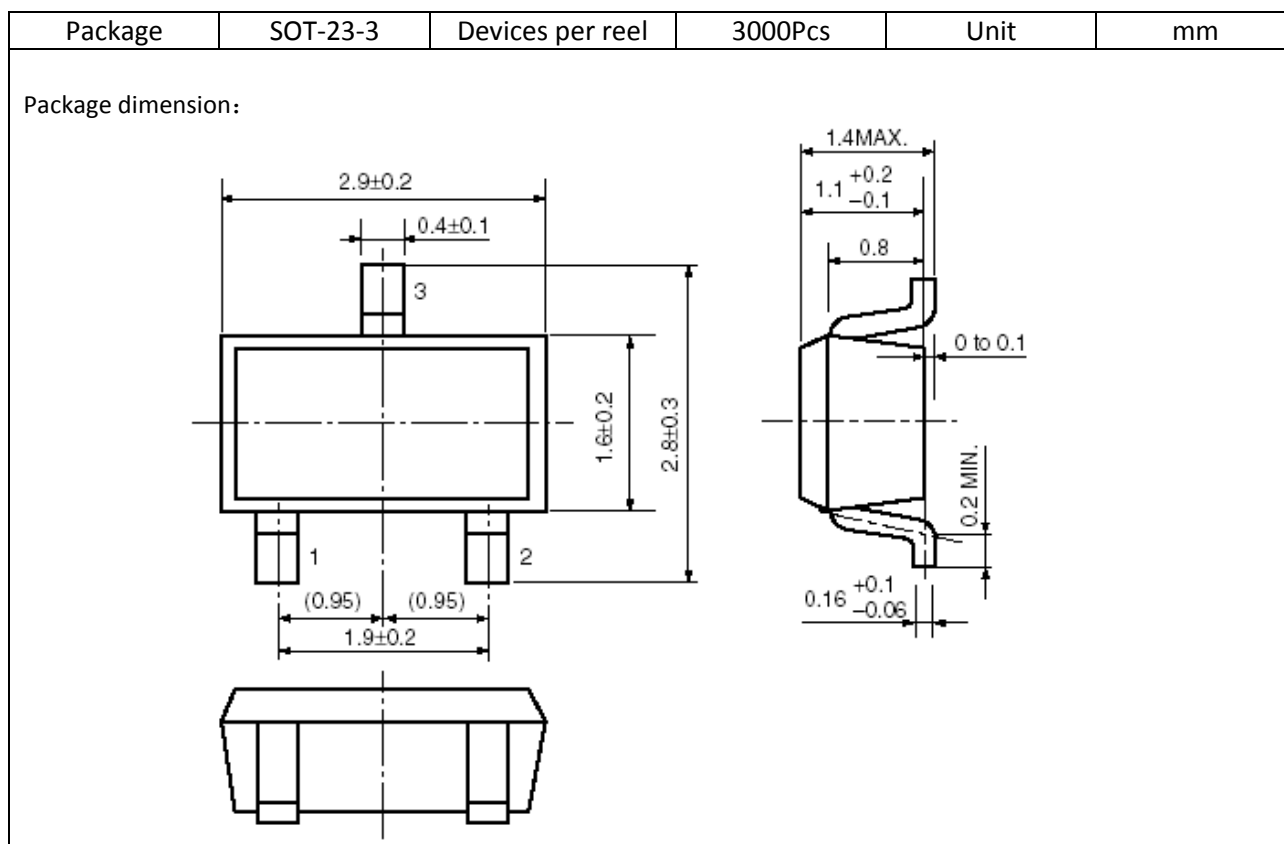

BL8531

Package	SOT-89-3	Devices per reel	1000Pcs	Unit	mm
Package Dimension:					
<p>Technical drawing of the SOT-89-3 package showing three views: top, side, and bottom. Dimensions are provided in millimeters with tolerances.</p> <ul style="list-style-type: none"> Top View: Overall width is 4.5 ± 0.1 mm. The distance between the two outer leads is 1.6 ± 0.2 mm. The diameter of the central hole is $\varnothing 1.0$ mm. The distance from the center of the hole to the top edge is 2.5 ± 0.1 mm. The maximum height of the package is 4.25 MAX. mm. The distance from the center of the hole to the bottom edge is 0.8 MIN. mm. The distance from the center of the hole to the center of the top lead is 0.4 mm. Side View: The distance from the top edge to the top of the lead is 1.5 ± 0.1 mm. The distance from the top of the lead to the top edge of the package is 0.4 ± 0.1 mm. The distance from the bottom edge to the bottom of the lead is 0.4 ± 0.1 mm. Bottom View: The distance between the two outer leads is 1.5 ± 0.1 mm. The distance from the center of the hole to the center of each lead is 0.42 ± 0.2 mm. The distance from the center of the hole to the center of the top lead is 0.47 ± 0.1 mm. 					

Package	TO-92	Devices per Bag	1000Pcs	Unit	mm
Package Dimension:					
<p>Technical drawing of the TO-92 package showing two views: front and side. Dimensions are provided in millimeters with tolerances.</p> <ul style="list-style-type: none"> Front View: The diameter of the top edge is $\varnothing 4.5 \pm 0.1$ mm. The height of the package is 4.95 ± 0.35 mm. The distance from the top edge to the top of the lead is 0.46 mm. The distance from the top of the lead to the top edge of the package is 1.5 mm. The distance from the bottom edge to the bottom of the lead is 0.5 mm. The distance from the bottom edge to the bottom of the package is 14.3 ± 0.1 mm. The distance from the bottom edge to the bottom of the lead is 0.38 mm. Side View: The distance from the top edge to the top of the lead is 3.5 ± 0.1 mm. The distance from the top of the lead to the top edge of the package is 1.25 ± 0.1 mm. The distance from the bottom edge to the bottom of the lead is 0.38 mm. The diameter of the bottom edge is $\varnothing 1.5 \times 0.2$ mm. The distance from the top edge to the center of the lead is 2.54 mm. 					