

## 300mA High PSRR, Linear Regulator

### DESCRIPTION

BL8554 series is a group of positive voltage output, low power consumption, low dropout voltage regulator.

BL8554 can provide output value in the range of 1.0V~4.5V every 0.1V step. It also can be customized on command.

BL8554 includes high accuracy voltage reference, error amplifier, current limit circuit and output driver module.

BL8554 has excellent load and line transient response and good temperature characteristics, which can assure the stability of chip and power system. And it uses trimming technique to guarantee output voltage accuracy within  $\pm 2\%$ .

BL8554 is available in SOT-23-5, SC-70-5 and SOT23-3 packages which is lead free.

### FEATURES

- Low Power Consumption: 25uA (Typ.)
- Low output noise (47uVRMS)
- Standby Mode: 0.1uA
- Low dropout Voltage: 0.16V@300mA (Typ.)
- High Ripple Rejection: 73dB@100Hz (Typ.)
- Low Temperature Coefficient:  $\pm 100\text{ppm}/^\circ\text{C}$
- Excellent Line regulation: 0.05%/V
- Build-in chip enable circuit
- Output Voltage Range: 1.0V~4.5V (customized on command every 0.1V step)
- Highly Accurate:  $\pm 2\%$
- Output Current Limit

### APPLICATIONS

- Power source for cellular phones and various kind of PCSs
- Battery Powered equipment
- Power Management of MP3, PDA, DSC, Mouse, PS2 Games
- Reference Voltage Source
- Regulation after Switching Power

### TYPICAL APPLICATION

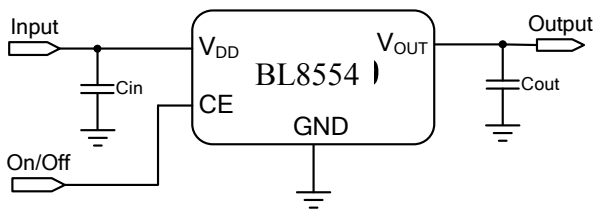

**NOTE:** Input capacitor ( $C_{in}=1\mu\text{F}$ ) and Output capacitor ( $C_{out}=3.3\mu\text{F}/4.7\mu\text{F}$ ) are recommended in all application circuit.

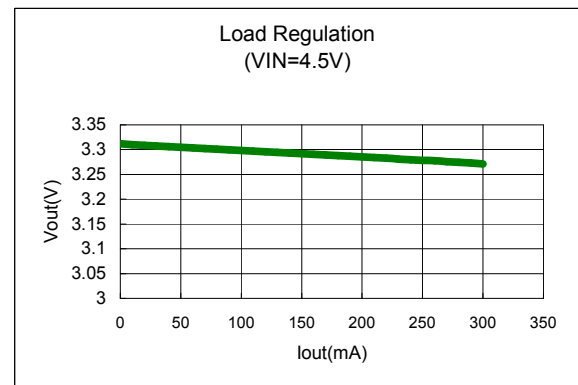

### ELECTRICAL CHARACTERISTICS

## ORDERING INFORMATION

BL8554 [1] [2] [3] [4]

Code	Description
[1]	Temperature&Rohs: C:-40~85°C ,Pb Free Rohs Std.
[2]	Package type: A5:SC-70-5 B5A:SOT-23-5(A) B5B:SOT-23-5(B) B3: SOT23-3
[3]	Packing type: TR:Tape&Reel (Standard)
[4]	Output voltage: e.g. 15=1.5V 18=1.8V 45=4.5V

## MARKING DESCRIPTON

M: Product Code  
X: Output Voltage

Vout	Code	Vout	Code	Vout	Code
1.0V	0	2.3V	$\bar{3}$	3.6V	$\bar{6}$
1.1V	1	2.4V	$\bar{4}$	3.7V	$\bar{7}$
1.2V	2	2.5V	$\bar{5}$	3.8V	$\bar{8}$
1.3V	3	2.6V	$\bar{6}$	3.9V	$\bar{9}$
1.4V	4	2.7V	$\bar{7}$	4.0V	$\bar{0}$
1.5V	5	2.8V	$\bar{8}$	4.1V	$\bar{1}$
1.6V	6	2.9V	$\bar{9}$	4.2V	$\bar{2}$
1.7V	7	3.0V	$\bar{0}$	4.3V	$\bar{3}$
1.8V	8	3.1V	$\bar{1}$	4.4V	$\bar{4}$
1.9V	9	3.2V	$\bar{2}$	4.5V	$\bar{5}$
2.0V	$\bar{0}$	3.3V	$\bar{3}$		
2.1V	$\bar{1}$	3.4V	$\bar{4}$		
2.2V	$\bar{2}$	3.5V	$\bar{5}$		

Y: The Year of manufacturing, "8" stands for year 2008, "9" stands for year 2009, and " $\bar{0}$ " stands for year 2010.

W: The week of manufacturing. "A" stands for week 1, "Z" stands for week 26, " $\bar{A}$ " stands for week 27, " $\bar{Z}$ " stands for week 52.

## PIN CONFIGURATION

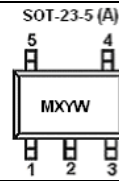
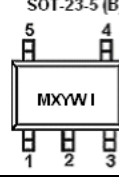
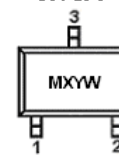
Product Classification	BL8554CA5TR□□	
M: Product Code		
X: Output Voltage		1 Vin 2 Vss 3 CE 4 NC 5 Vout
YW: Date Code		
Product Classification	BL8554CB5ATR□□	
M: Product Code		
X: Output Voltage		1 Vin 2 Vss 3 CE 4 NC 5 Vout
YW: Date Code		
Product Classification	BL8554CB5BTR□□	
M: Product Code		
X: Output Voltage		1 Vout 2 Vss 3 Vin 4 CE 5 NC
YW: Date Code		
I: B type		
Product Classification	BL8554CB3TR□□	
M: Product Code		
X: Output Voltage		1. Vss 2. Vout 3. Vin
YW: Date Code		
Vss	Ground Pin	
Vin	Supply Voltage Input	
Vout	Output Voltage	
CE	Chip Enable	
NC	No Connection	

### Optional marking information:

From one source of assembly house, there are dots in addition to formal marking information. One is the pin1 indicator and the other is for internal identification of the assembly house. The dots are illustrated as below:

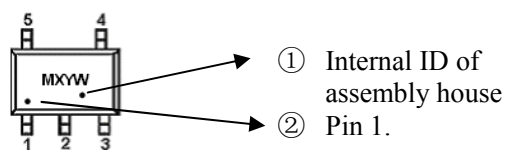

## ABSOLUTE MAXIMUM RATING

Parameter		Value
Max Input Voltage		8V
Operating Junction Temperature(Tj)		125°C
Output Current		300mA
Ambient Temperature(Ta)		-40°C -85°C
Power Dissipation	SC70-5	250mW
	SOT-23-5	250mW
	SOT-23-3	250mW
Storage Temperature(Ts)		-40°C -150°C
Lead Temperature & Time		260°C,10S

Note:

Exceed these limits to damage to the device.

Exposure to absolute maximum rating conditions may affect device reliability.

## RECOMMENDED WORK CONDITIONS

Item	Min	Recommended	Max.	Unit
Input Voltage Range	2		6	V
Ambient Temperature	-40		85	°C

## ELECTRICAL CHARACTERISTICS

(Test Conditions: Cin=1uF, Cout=3.3uF, TA=25°C, unless otherwise specified. )

BL8554, For Arbitrary Output Voltage

Symbol	Parameter	Conditions	Min	Typ	Max	Units	
Vin	Input Voltage		2		6	V	
Vout	Output Voltage	V <sub>OUT</sub> >1.5V	Vin=Set Vout+1V 1mA≤I <sub>out</sub> ≤30mA	Vout x0.98	Vout	Vout X1.02	V
		V <sub>OUT</sub> ≤1.5V		Vout -0.03		Vout +0.03	
I <sub>out</sub> (Max.)	Maximum Output Current	Vin-Vout=1V	300			mA	
V <sub>drop</sub> <sup>1</sup>	Dropout Voltage, Vout≥2.8V	I <sub>out</sub> =100mA		50	80	mV	
		I <sub>out</sub> =300mA		160	220	mV	
$\frac{\Delta V_{out}}{\Delta V_{in} \cdot V_{out}}$	Line Regulation	I <sub>out</sub> =40mA 2.8V≤Vin≤6V		0.05	0.2	%/V	
$\Delta V_{out} / \Delta I_{out}$	Load Regulation	Vin=Set Vout+1V 1mA≤I <sub>out</sub> ≤300mA		60	100	mV	
I <sub>ss</sub>	Supply Current	Vin=Set Vout+1V		25	50	uA	
I <sub>standby</sub>	Supply Current (Srandby)	Vin=Set Vout+1V Vce=GND		0.1	1.0	uA	
$\frac{\Delta V_{out}}{\Delta T \cdot V_{out}}$	Output Voltage Temperature Coefficiency	I <sub>out</sub> =30mA		± 100		ppm/°C	

# BL8554

PSRR	Ripple Rejection	F=100Hz, Ripple=0.5Vp-p Vin=Set Vout+1V		70		dB
Ilim	Short Current Limit	Vout=0V		500		mA
Vceh	CE Input Voltage "H"		1.5		Vin	V
Vcel	CE Input Voltage "L"		0		0.25	V
en	Output Noise	BW=10Hz~100kHz		47		uVrms

**NOTE:**

$V_{drop} = V_{in1} - (V_{out2} * 0.98)$   $V_{out2}$  is the output voltage when  $V_{in} = V_{out1} + 1.0V$  and  $I_{out} = 300mA$ .

$V_{in1}$  is the input voltage at which the output voltage becomes 98% of  $V_{out1}$  after gradually decreasing the input voltage.

## BLOCK DIAGRAM

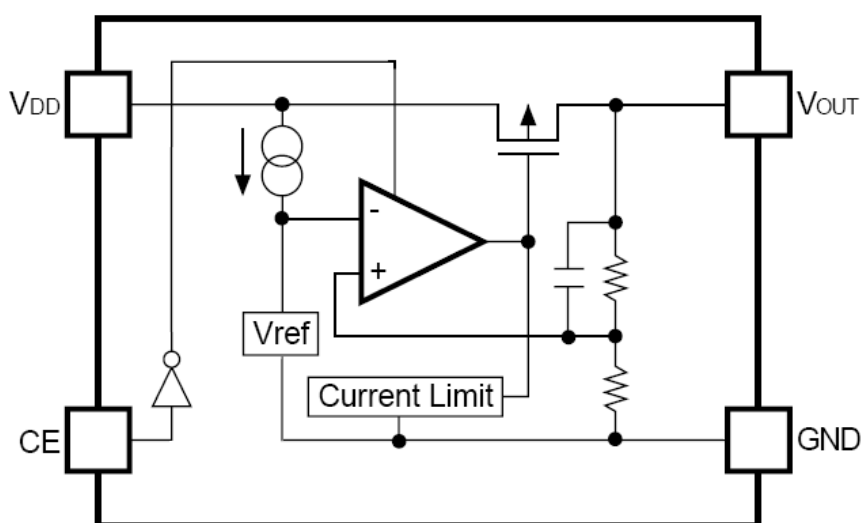

## Explanation

BL8554 series is a group of positive voltage output, low noise, low power consumption, low dropout voltage regulator.

BL8554 can provide output value in the range of 1.0V~4.5V every 0.1V step. It also can be customized on command.

BL8554 includes high accuracy voltage reference, error amplifier, current limit circuit and output driver module.

BL8554 has excellent load and line transient response, and good temperature characteristics, which can assure the stability of chip and power system. And it uses trimming technique to guarantee output voltage accuracy within  $\pm 2\%$ .

## TYPICAL PERFORMANCE CHARACTERISTICS

1) Output Voltage vs. Output Current (with output short protection)

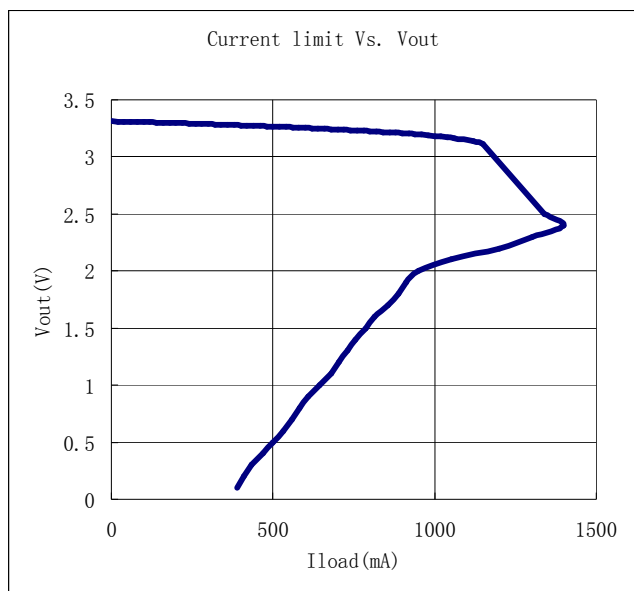

2) Output Voltage vs. Input Voltage

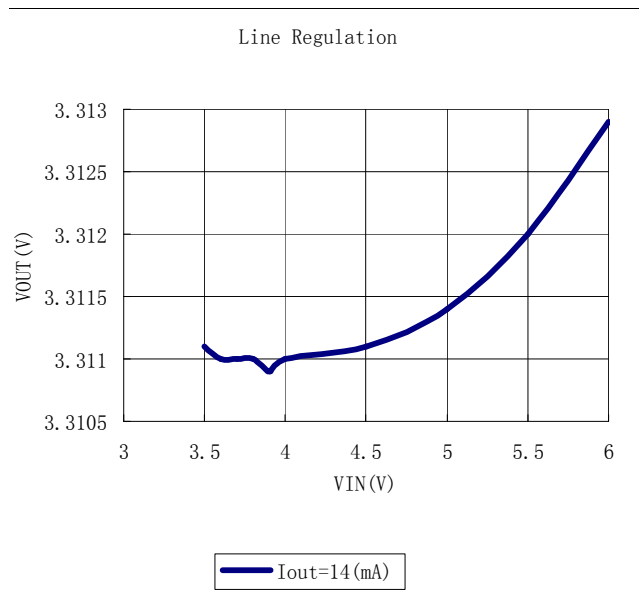

3) Dropout Voltage vs. Output Current

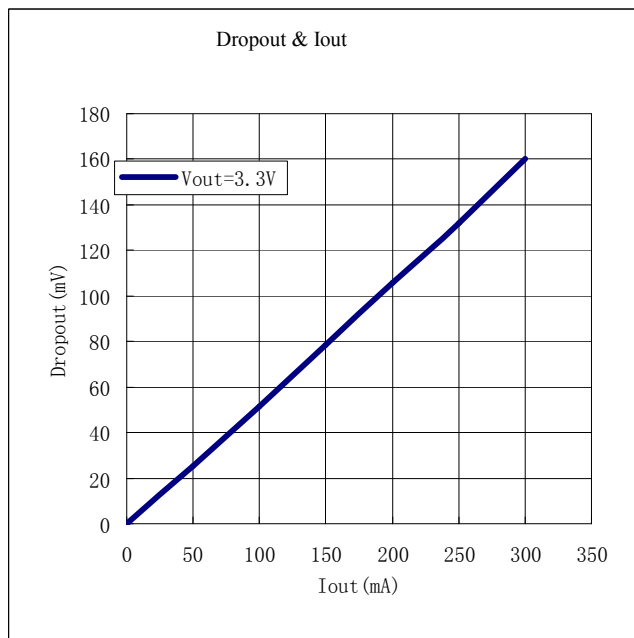

4) Ripple rejection vs. Frequency

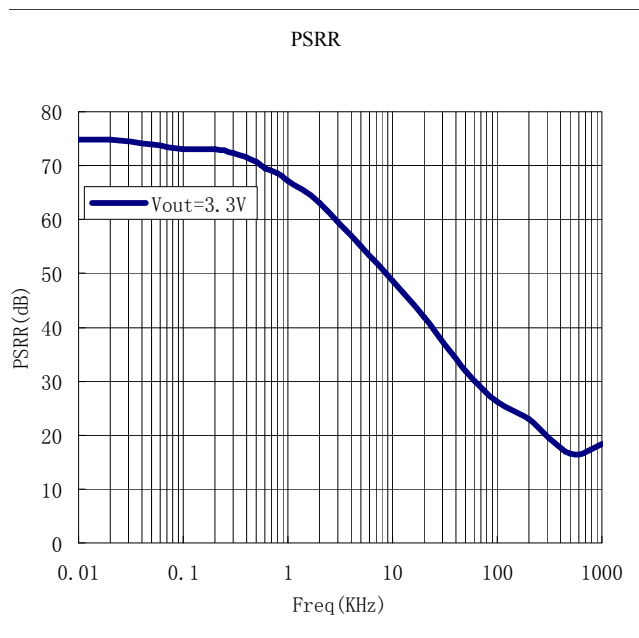

## 5) Line transient response

$C_{in}=C_{out}=1\mu F$   $I_{out}=25mA$   $V_{out}=3.3V$

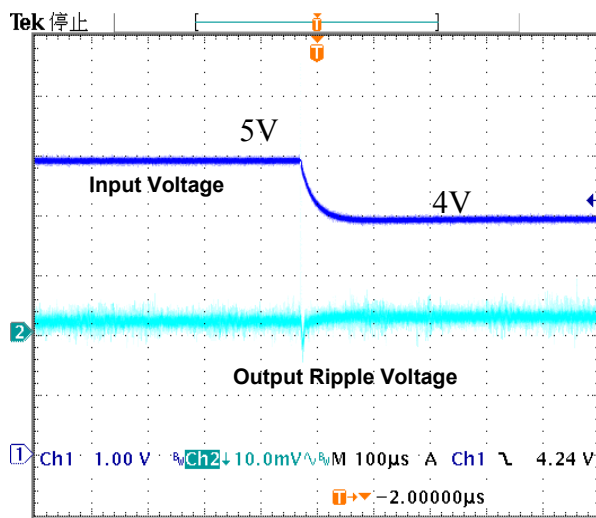
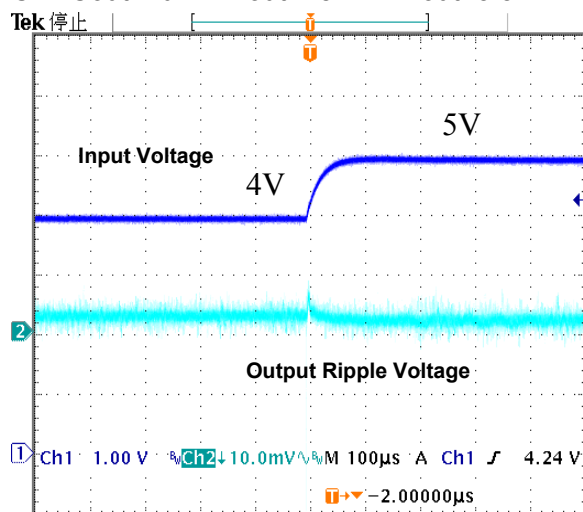

## 6) Load transient response

$C_{in}=C_{out}=1\mu F$   $V_{in}=4.5V$   $V_{out}=3.3V$

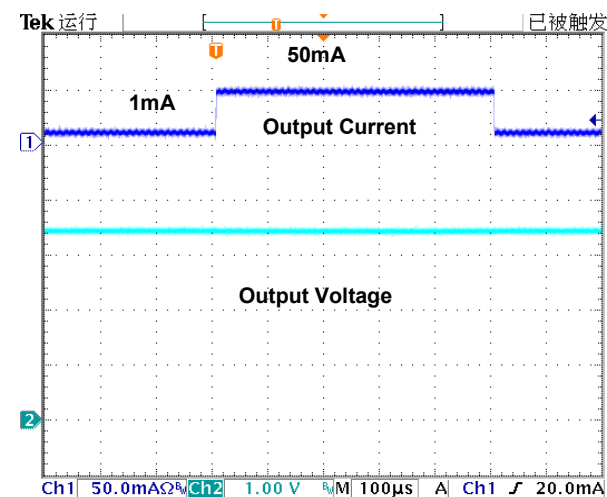
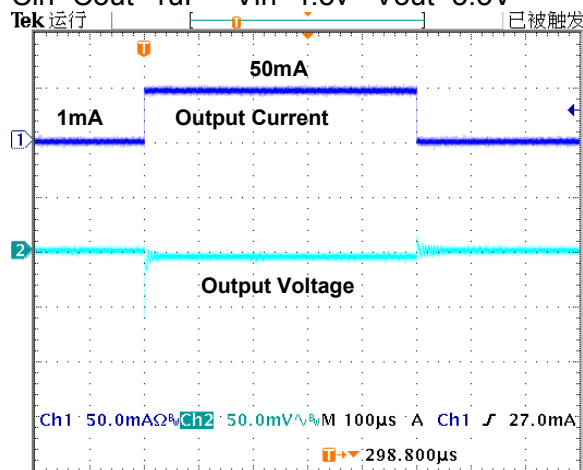

## 7) Start up from EN

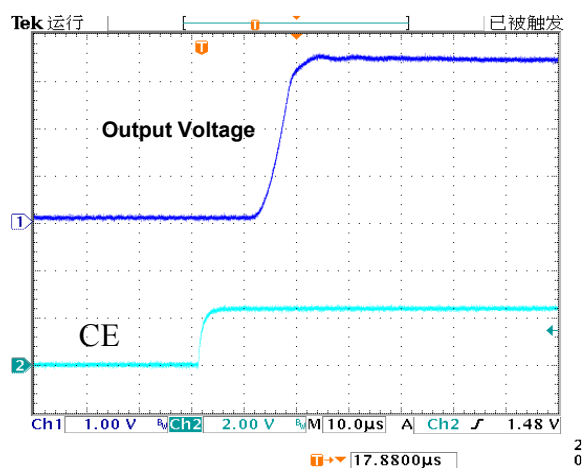

## 8) Shut down from EN

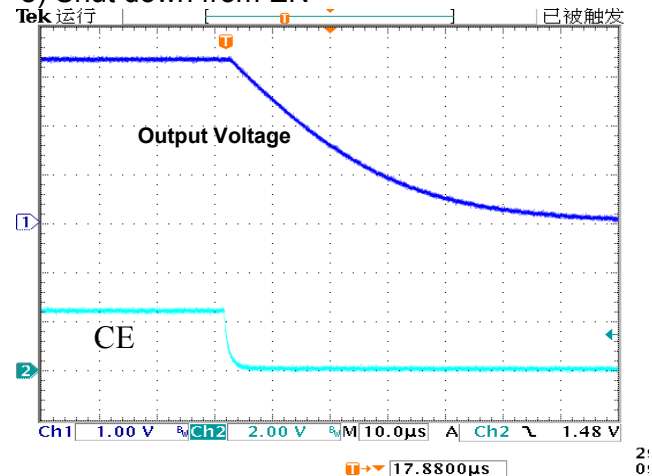

## PACKAGE OUTLINE

Package	SC70-5	Devices per reel	3000Pcs	Unit	mm
<p>Package dimension:</p> <p>Top view dimensions: <math>2.025 \pm 0.025</math> (width), <math>2.125 \pm 0.325</math> (height), <math>1.25 \pm 0.1</math> (lead height), <math>0.275 \pm 0.125</math> (lead width).</p> <p>Side view dimensions: <math>0.17 \pm 0.09</math> (lead thickness), <math>0.335 \pm 0.125</math> (lead length).</p> <p>End view dimensions: <math>0.95 \pm 0.15</math> (lead height), <math>0.65</math> (lead width), <math>0.1</math> (lead thickness).</p>					

Package	SOT-23-5	Devices per reel	3000Pcs	Unit	mm
<p>Package Dimension:</p> <p>Top view dimensions: <math>2.9 \pm 0.2</math> (width), <math>1.9 \pm 0.2</math> (lead width), <math>0.95</math> (lead width), <math>0.95</math> (lead width), <math>1.0 \pm 0.2</math> (lead height), <math>1.6 \pm 0.1</math> (lead height), <math>2.8 \pm 0.3</math> (height), <math>0.4 \pm 0.1</math> (lead width), <math>0.1</math> (lead thickness).</p> <p>Side view dimensions: <math>1.1 \pm 0.1</math> (lead width), <math>0.8 \pm 0.1</math> (lead width), <math>0.15 \pm 0.1</math> (lead width), <math>0.2</math> MIN. (lead thickness), <math>0</math> to <math>0.1</math> (lead thickness).</p> <p>End view dimensions: <math>0.95</math> (lead width), <math>0.95</math> (lead width), <math>0.1</math> (lead thickness).</p>					

# BL8554

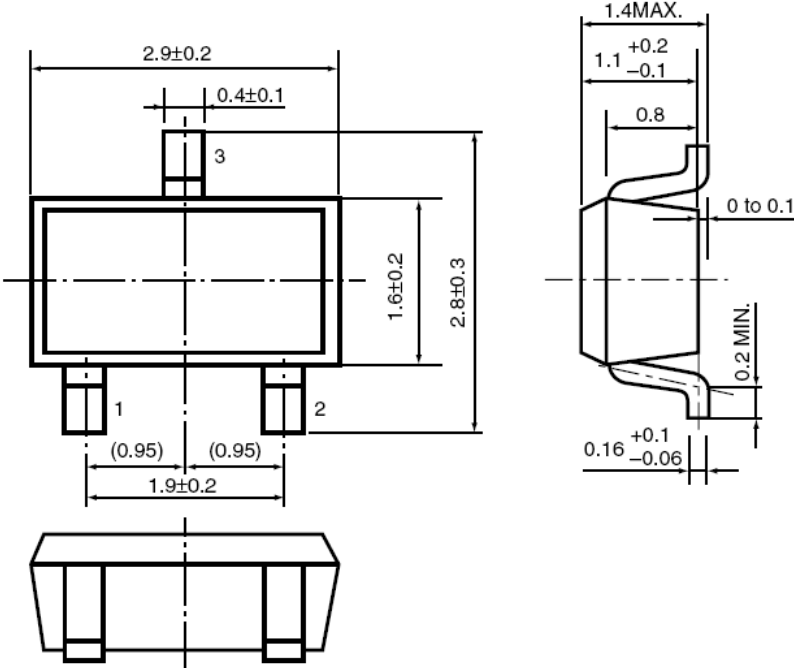
Package	SOT-23-3	Devices per reel	3000Pcs	Unit	mm
Package Dimension:					
 <p>The technical drawing illustrates the BL8554 package in three views: top, side, and perspective. The top view shows a rectangular body with a width of <math>2.9 \pm 0.2</math> mm and a body width of <math>1.6 \pm 0.2</math> mm. The distance between the two leads is <math>1.9 \pm 0.2</math> mm, with each lead having a width of <math>0.95</math> mm. The lead length is <math>0.4 \pm 0.1</math> mm, and the lead thickness is <math>0.16</math> mm. The side view shows a total height of <math>2.8 \pm 0.3</math> mm, with a lead height of <math>1.1</math> mm (tolerance <math>+0.2/-0.1</math>) and a lead thickness of <math>0.16</math> mm (tolerance <math>+0.1/-0.06</math>). The lead width at the base is <math>0.8</math> mm, and the lead thickness at the base is <math>0.2</math> mm (minimum). The lead angle is <math>0</math> to <math>0.1</math> degrees. The perspective view shows the package from an isometric angle.</p>					