

BLM8G0710S-15PB; BLM8G0710S-15PBG

LDMOS 2-stage power MMIC

Rev. 4 — 18 April 2018

AMPLEON

Product data sheet

1. Product profile

1.1 General description

The BLM8G0710S-15PB(G) is a dual section, 2-stage power MMIC using Ampleon's state of the art GEN8 LDMOS technology. This multiband device is perfectly suited as general purpose driver or small cell final in the frequency range from 700 MHz to 1000 MHz. Available in gull wing or straight lead outline.

Table 1. Performance

Typical RF performance at $T_{case} = 25\text{ °C}$; $I_{Dq1} = 15\text{ mA}$; $I_{Dq2} = 60\text{ mA}$.

Test signal: 3GPP test model 1; 64 DPCH; PAR = 9.9 dB at 0.01 % probability on CCDF; per section unless otherwise specified in a class-AB production circuit.

Test signal	f	V _{DS}	P _{L(AV)}	G _p	η _D	ACPR _{5M}
	(MHz)	(V)	(W)	(dB)	(%)	(dBc)
single carrier W-CDMA	957.5	28	1.5	36	27	-41

1.2 Features and benefits

- Designed for broadband operation (frequency 700 MHz to 1000 MHz)
- High section-to-section isolation enabling multiple combinations
- Integrated temperature compensated bias
- Biasing of individual stages is externally accessible
- Integrated ESD protection
- Excellent thermal stability
- High power gain
- On-chip matching for ease of use
- For RoHS compliance see the product details on the Ampleon website

1.3 Applications

- RF power MMIC for W-CDMA base stations in the 700 MHz to 1000 MHz frequency range. Possible circuit topologies are the following as also depicted in [Section 8.1](#):
 - ◆ Dual section or single ended
 - ◆ Doherty
 - ◆ Quadrature combined
 - ◆ Push-pull

2. Pinning information

2.1 Pinning

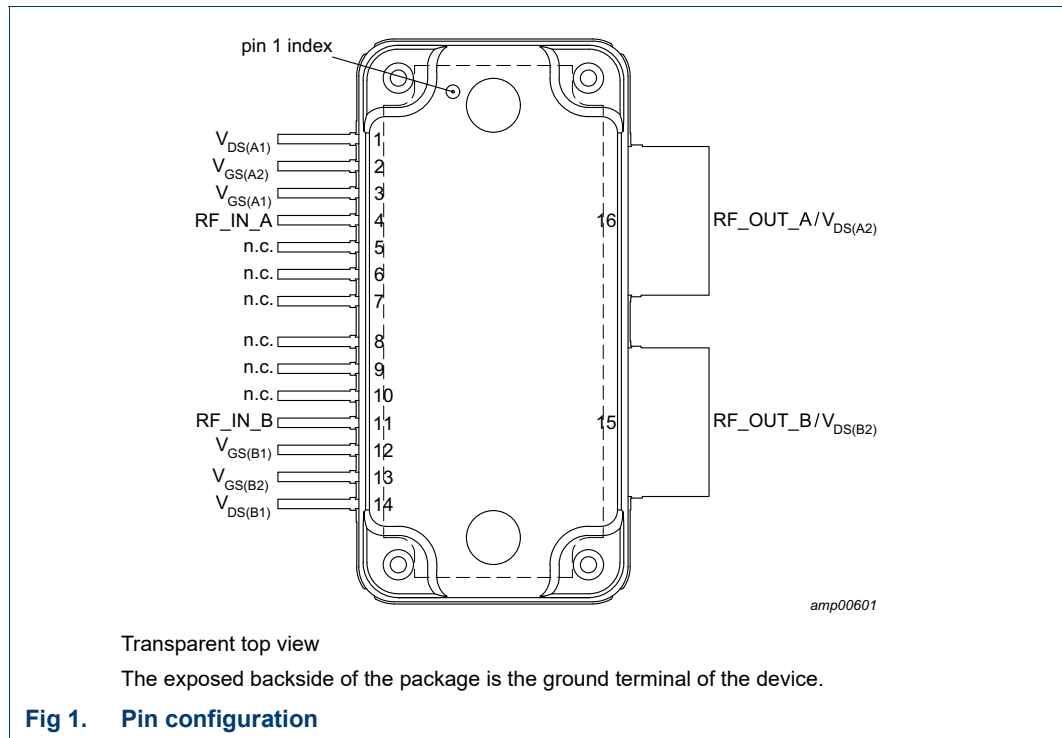

2.2 Pin description

Table 2. Pin description

Symbol	Pin	Description
$V_{DS(A1)}$	1	drain-source voltage of stage (A1)
$V_{GS(A2)}$	2	gate-source voltage of stage (A2)
$V_{GS(A1)}$	3	gate-source voltage of stage (A1)
RF_IN_A	4	RF input section A
n.c.	5	not connected
n.c.	6	not connected
n.c.	7	not connected
n.c.	8	not connected
n.c.	9	not connected
n.c.	10	not connected
RF_IN_B	11	RF input section B
$V_{GS(B1)}$	12	gate-source voltage of stage (B1)
$V_{GS(B2)}$	13	gate-source voltage of stage (B2)
$V_{DS(B1)}$	14	drain-source voltage of stage (B1)

Table 2. Pin description ...continued

Symbol	Pin	Description
RF_OUT_B/ $V_{DS(B2)}$	15	RF output section B / drain-source voltage of stage (B2)
RF_OUT_A/ $V_{DS(A2)}$	16	RF output section A / drain-source voltage of stage (A2)
GND	flange	RF ground

3. Ordering information

Table 3. Ordering information

Type number	Package		
	Name	Description	Version
BLM8G0710S-15PB	-	plastic, heatsink small outline package; 16 leads (flat)	SOT1211-3
BLM8G0710S-15PBG	-	plastic, heatsink small outline package; 16 leads	SOT1212-3

4. Block diagram

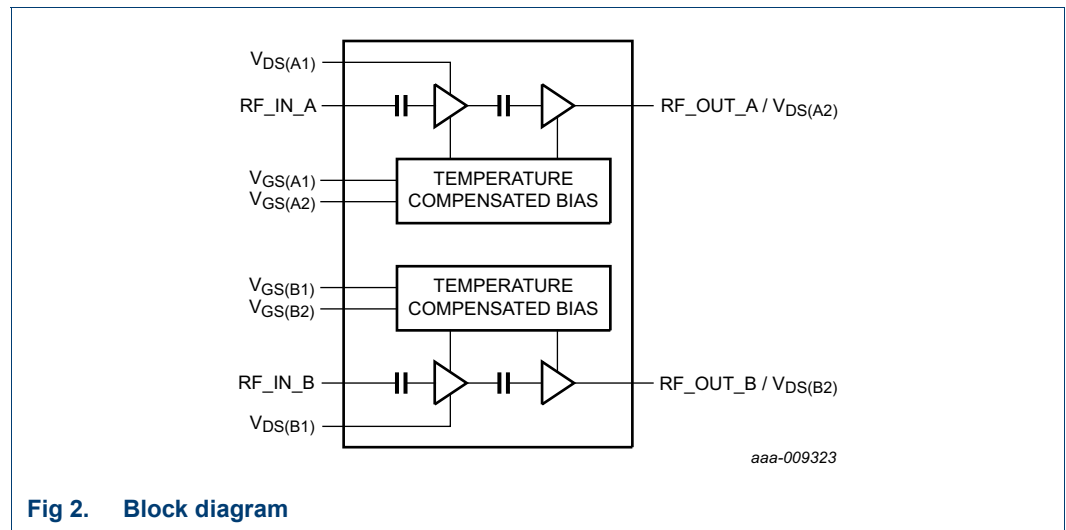

5. Limiting values

Table 4. Limiting values

In accordance with the Absolute Maximum Rating System (IEC 60134).

Symbol	Parameter	Conditions	Min	Max	Unit
V_{DS}	drain-source voltage		-	65	V
V_{GS}	gate-source voltage		-0.5	+13	V
T_{stg}	storage temperature		-65	+150	°C
T_j	junction temperature	[1]	-	225	°C
T_{case}	case temperature		-	150	°C

[1] Continuous use at maximum temperature will affect the reliability. For details refer to the online MTF calculator.

6. Thermal characteristics

Table 5. Thermal characteristics
Measured for total device.

Symbol	Parameter	Conditions	Value	Unit
R _{th(j-c)}	thermal resistance from junction to case	final stage; T _{case} = 90 °C; P _L = 1.26 W [1]	2.41	K/W
		driver stage; T _{case} = 90 °C; P _L = 1.26 W [1]	7.5	K/W

[1] When operated with a CW signal.

7. Characteristics

Table 6. DC characteristics
T_{case} = 25 °C; per section unless otherwise specified.

Symbol	Parameter	Conditions	Min	Typ	Max	Unit
Final stage						
V _{(BR)DSS}	drain-source breakdown voltage	V _{GS} = 0 V; I _D = 0.12 mA	65	-	-	V
V _{GSq}	gate-source quiescent voltage	V _{DS} = 28 V; I _D = 60 mA	1.6	2.1	2.5	V
		V _{DS} = 28 V; I _D = 60 mA [1]	1.6	2.6	3.6	V
ΔI _{Dq} /ΔT	quiescent drain current variation with temperature	-40 °C ≤ T _{case} ≤ +85 °C [1]	-	2	-	%
I _{DSS}	drain leakage current	V _{GS} = 0 V; V _{DS} = 28 V	-	-	1.4	μA
I _{DSX}	drain cut-off current	V _{GS} = 5.65 V; V _{DS} = 10 V	-	2.2	-	A
I _{GSS}	gate leakage current	V _{GS} = 1 V; V _{DS} = 0 V	-	-	140	nA
Driver stage						
V _{(BR)DSS}	drain-source breakdown voltage	V _{GS} = 0 V; I _D = 0.03 mA	65	-	-	V
V _{GSq}	gate-source quiescent voltage	V _{DS} = 28 V; I _D = 15 mA	1.6	2.1	2.5	V
		V _{DS} = 28 V; I _D = 15 mA [2]	1.6	2.6	3.5	V
ΔI _{Dq} /ΔT	quiescent drain current variation with temperature	-40 °C ≤ T _{case} ≤ +85 °C [2]	-	2	-	%
I _{DSS}	drain leakage current	V _{GS} = 0 V; V _{DS} = 28 V	-	-	1.4	μA
I _{GSS}	gate leakage current	V _{GS} = 1 V; V _{DS} = 0 V	-	-	140	nA

[1] In production circuit with 1.3 kΩ gate feed resistor.

[2] In production circuit with 1.2 kΩ gate feed resistor.

Table 7. RF Characteristics
Typical RF performance at f = 957.5 MHz; T_{case} = 25 °C; V_{DS} = 28 V; I_{Dq1} = 15 mA (driver stage); I_{Dq2} = 60 mA (final stage); P_{L(AV)} = 1.5 W. Unless otherwise specified, measured in an Ampleon straight lead production circuit.

Symbol	Parameter	Conditions	Min	Typ	Max	Unit
Test signal: single carrier W-CDMA [1]						
G _p	power gain	f = 730.5 MHz	-	36	-	dB
		f = 957.5 MHz	34.5	36	37.5	dB
η _D	drain efficiency	f = 730.5 MHz	-	23	-	%
		f = 957.5 MHz	22.5	27	-	%

Table 7. RF Characteristics ...continued

Typical RF performance at $f = 957.5$ MHz; $T_{case} = 25$ °C; $V_{DS} = 28$ V; $I_{Dq1} = 15$ mA (driver stage); $I_{Dq2} = 60$ mA (final stage); $P_{L(AV)} = 1.5$ W. Unless otherwise specified, measured in an Ampleon straight lead production circuit.

Symbol	Parameter	Conditions	Min	Typ	Max	Unit
RL _{in}	input return loss	f = 730.5 MHz	-	-18	-	dB
		f = 957.5 MHz	-	-16	-10	dB
ACPR _{5M}	adjacent channel power ratio (5 MHz)	f = 730.5 MHz	-	-38.7	-	dBc
		f = 957.5 MHz	-	-41	-36	dBc
PAR _O	output peak-to-average ratio	f = 730.5 MHz	-	8.8	-	dB
		f = 957.5 MHz	7	8.1	-	dB
Test signal: CW [2]						
$\Delta\phi_{s21}$	phase response difference	between sections	-10	-	+10	deg
$\Delta s_{21} ^2$	insertion power gain difference	between sections	-0.5	-	+0.5	dB

[1] 3GPP test model 1; 64 DPCH; PAR = 9.9 dB at 0.01 % probability on CCDF.

[2] f = 957.5 MHz.

8. Application information

Table 8. Typical performance

Test signal: 1-tone CW; RF performance at $T_{case} = 25$ °C; $V_{DS} = 28$ V; $I_{Dq1} = 15$ mA; $I_{Dq2} = 60$ mA unless otherwise specified, measured in an Ampleon wideband f = 700 MHz to 1000 MHz class AB application circuit.

Symbol	Parameter	Conditions	Min	Typ	Max	Unit
P _{L(1dB)}	output power at 1 dB gain compression	f = 800 MHz	-	23.3	-	W
η_D	drain efficiency	at P _{L(1dB)} ; f = 800 MHz	-	55	-	%
G _p	power gain	P _{L(AV)} = 4 W; f = 800 MHz	-	35	-	dB
B _{video}	video bandwidth	2-tone CW; P _{L(AV)} = 10 W; f = 800 MHz	-	190	-	MHz
G _{flat}	gain flatness	P _{L(AV)} = 4 W	-	1	-	dB
$\Delta G/\Delta T$	gain variation with temperature	f = 800 MHz	-	0.022	-	dB/°C
s ₁₂ ²	isolation	between sections A and B; P _{L(AV)} = 4 W; f = 800 MHz	-	29	-	dB
K	Rollett stability factor	T = -40 °C; f = 0.1 GHz to 3 GHz	-	3	-	

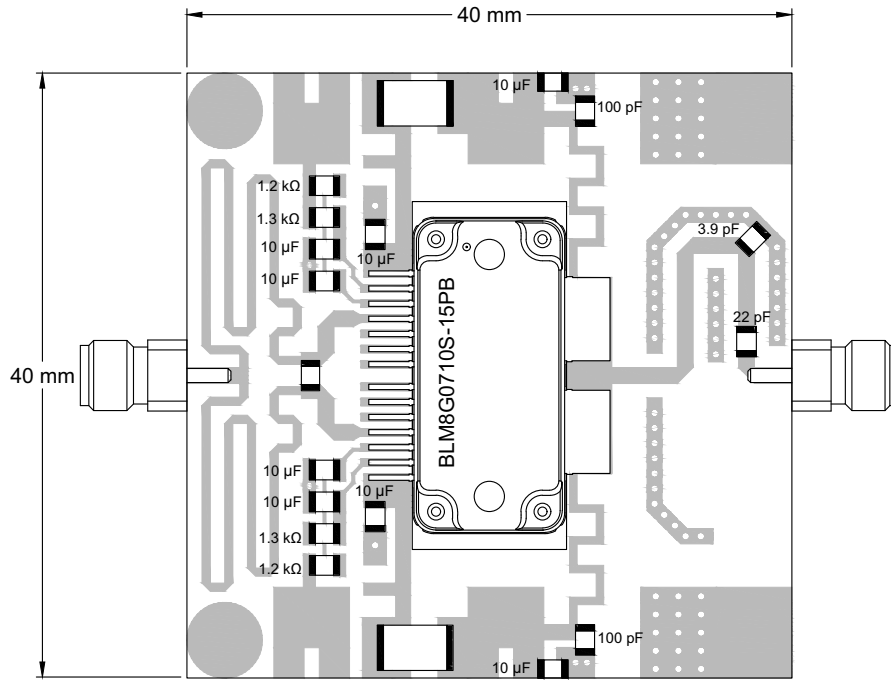

amp00683

Printed-Circuit Board (PCB): Rogers 4350; thickness = 0.508 mm.

Fig 3. Component layout for class-AB application circuit

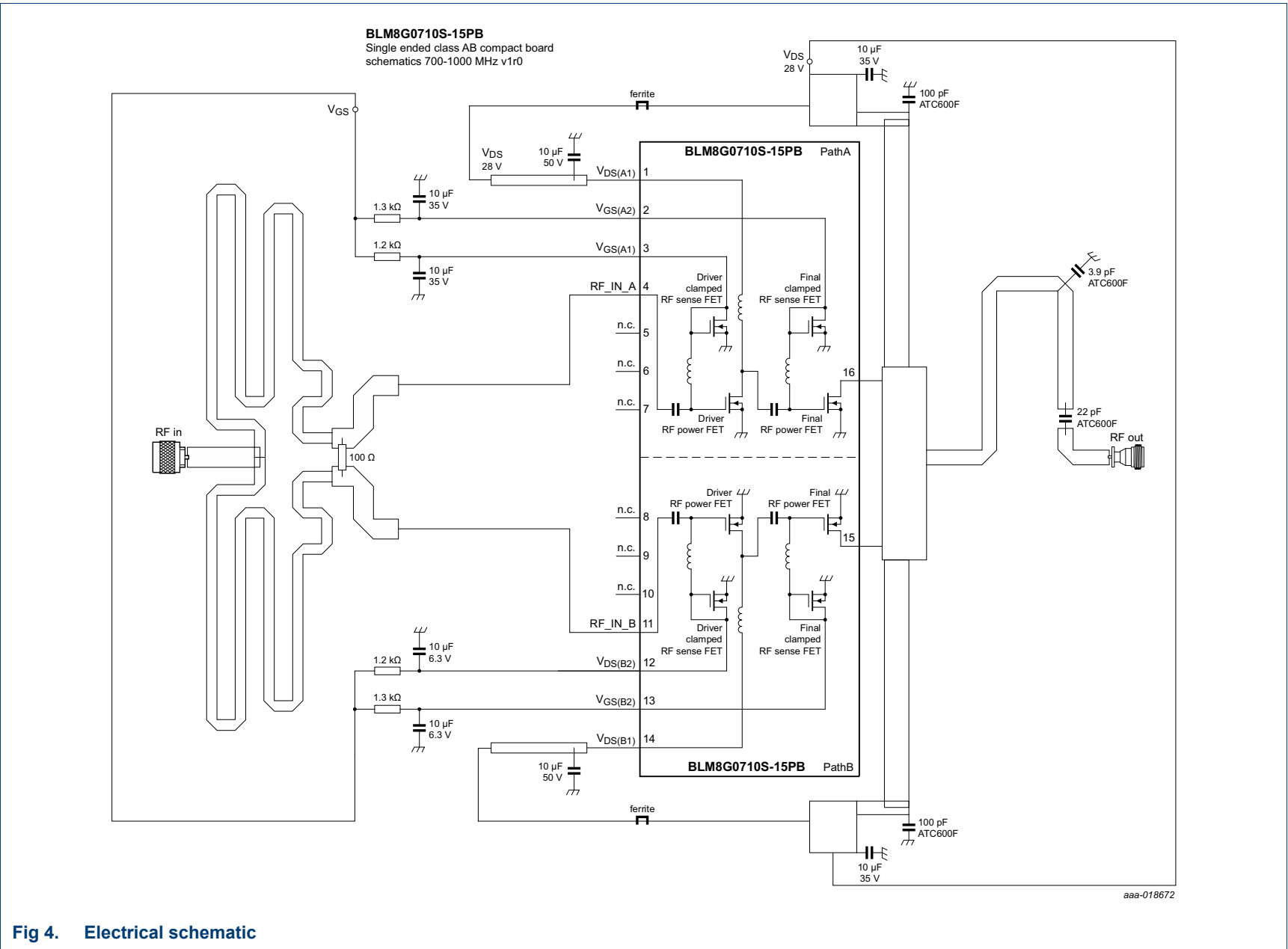

Fig 4. Electrical schematic

8.1 Possible circuit topologies

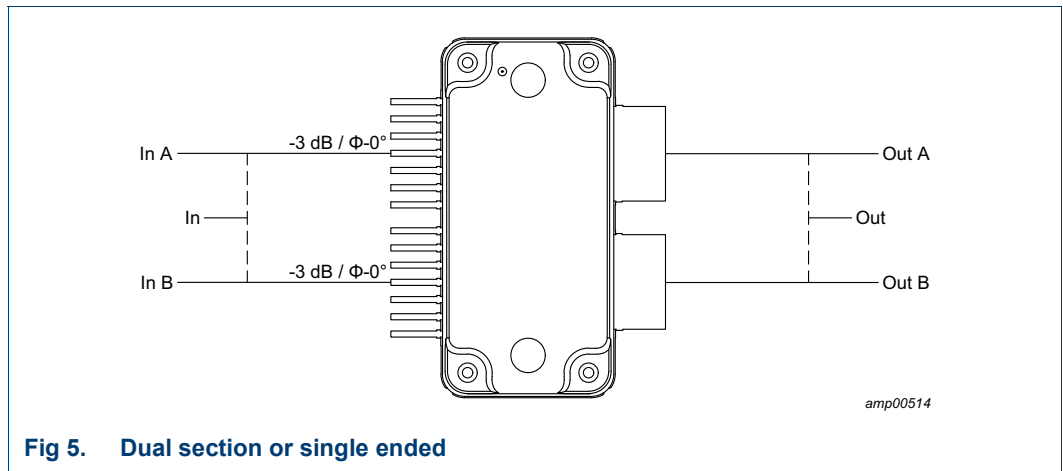

Fig 5. Dual section or single ended

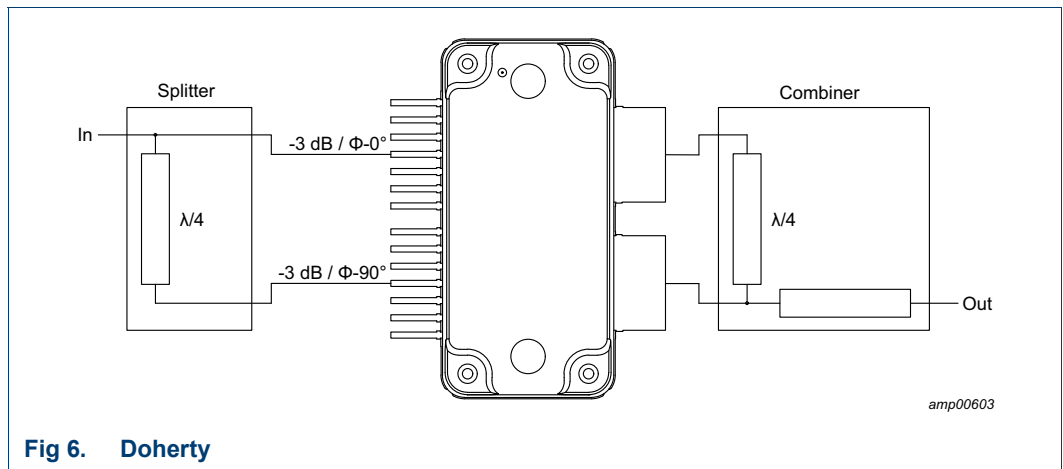

Fig 6. Doherty

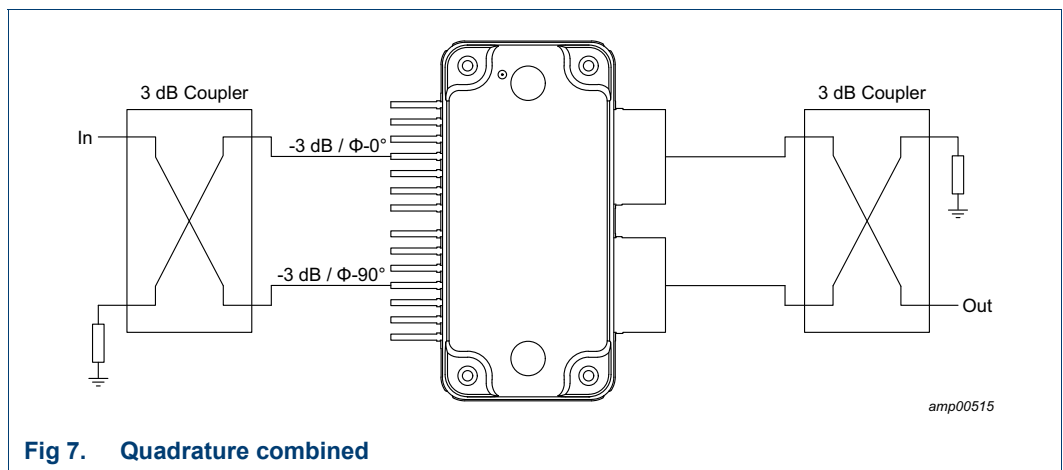

Fig 7. Quadrature combined

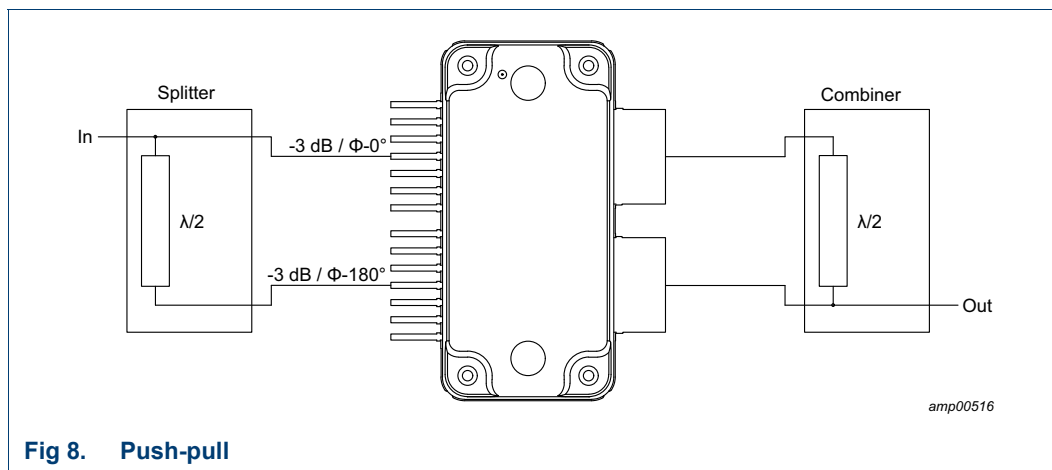

Fig 8. Push-pull

8.2 Ruggedness in class-AB operation

The BLM8G0710S-15PB and BLM8G0710S-15PBG are capable of withstanding a load mismatch corresponding to VSWR = 10 : 1 through all phases under the following conditions: $V_{DS} = 32\text{ V}$; $I_{Dq1} = 15\text{ mA}$; $I_{Dq2} = 60\text{ mA}$; P_i is corresponding to $P_{L(3dB)}$ under $Z_S = 50\ \Omega$ load; $f = 840\text{ MHz}$.

8.3 Impedance information

Table 9. Typical impedance tuned for maximum output power

Measured load-pull data per section; test signal: pulsed CW; $T_{case} = 25\text{ }^\circ\text{C}$; $V_{DS} = 28\text{ V}$; $I_{Dq1} = 15\text{ mA}$; $I_{Dq2} = 60\text{ mA}$; $t_p = 100\ \mu\text{s}$; $\delta = 10\%$; $Z_S = 50\ \Omega$. Typical values unless otherwise specified.

f (MHz)	at 1dB gain compression point					at 3dB gain compression point				
	Z_L (Ω)	$G_{p(max)}$ (dB)	P_L (dBm)	η_{add} (%)	AM-PM conversion (deg)	Z_L (Ω)	$G_{p(max)}$ (dB)	P_L (dBm)	η_{add} (%)	AM-PM conversion (deg)
BLM8G0710S-15PB										
680	17.5 + j5.9	36.4	40.9	57.9	-11.1	14.2 + j6.0	36.1	41.7	58.6	-12.5
700	14.3 + j5.8	36.4	40.7	53.9	-9.9	16.1 + j4.4	36.4	41.6	58.6	-10.6
720	14.3 + j5.7	36.3	40.6	53.4	-9	16.3 + j4.1	36.3	41.6	58.1	-9.5
740	15.4 + j7.2	36.4	40.7	57	-8.7	14.2 + j5.9	36	41.6	58	-9.7
760	15.4 + j7.2	35.9	40.6	57.2	-8.5	16.1 + j4.6	35.6	41.6	58.4	-9
780	16.1 + j4.6	35.2	40.7	54.3	-6.9	16.1 + j4.6	35.2	41.6	58.5	-7.6
800	14.2 + j5.9	34.9	40.6	53.4	-6.2	16.0 + j4.5	34.9	41.6	58.3	-6.2
820	14.1 + j5.9	34.8	40.7	54.4	-5.4	16.0 + j4.5	34.7	41.7	58.9	-5.4
840	14.1 + j5.9	34.8	40.8	54.7	-5.2	16.0 + j4.6	34.7	41.7	58.8	-5.3
860	16.0 + j4.6	34.7	40.8	54.7	-4.2	18.3 + j3.7	34.7	41.8	59.8	-3.7
880	18.3 + j3.6	34.7	40.9	55.4	-3.4	18.3 + j3.6	34.7	41.8	59.8	-3
900	18.2 + j3.6	34.9	40.9	55.4	-2.9	18.2 + j3.6	34.9	41.8	59.4	-2.4
920	18.2 + j3.7	35	40.9	54.8	-3	18.2 + j3.7	35	41.8	58.9	-2.6
940	18.2 + j3.8	35.2	40.8	54.7	-4.1	18.2 + j3.8	35.2	41.8	58.7	-4.1
960	18.3 + j3.8	35.2	40.8	54	-4.5	16.0 + j4.7	35.3	41.7	58.5	-5.2

Table 9. Typical impedance tuned for maximum output power ...continued

Measured load-pull data per section; test signal: pulsed CW; $T_{case} = 25\text{ }^{\circ}\text{C}$; $V_{DS} = 28\text{ V}$; $I_{Dq1} = 15\text{ mA}$; $I_{Dq2} = 60\text{ mA}$; $t_p = 100\text{ }\mu\text{s}$; $\delta = 10\text{ }\%$; $Z_S = 50\text{ }\Omega$. Typical values unless otherwise specified.

f (MHz)	at 1dB gain compression point					at 3dB gain compression point				
	Z _L (Ω)	G _{p(max)} (dB)	P _L (dBm)	η_{add} (%)	AM-PM conversion (deg)	Z _L (Ω)	G _{p(max)} (dB)	P _L (dBm)	η_{add} (%)	AM-PM conversion (deg)
980	18.3 + j3.7	35.1	40.7	53.5	-5.1	18.3 + j3.7	35.1	41.7	57.7	-5.6
1000	18.2 + j3.7	34.9	40.6	52.7	-5.6	18.2 + j3.7	34.9	41.6	57.2	-6.7
BLM8G0710S-15PBG										
700	14.6 + j5.2	35.8	40.7	53.7	-10.5	15.3 + j4.0	35.7	41.7	56.7	-11.7
720	14.1 + j6.2	35.8	40.7	54.7	-9	15.8 + j4.3	35.7	41.6	57.8	-9.6
740	14.2 + j5.1	35.7	40.7	52.9	-8	15.8 + j3.9	35.6	41.6	56.7	-9.2
760	15.0 + j4.1	35.3	40.6	52.5	-8.1	14.9 + j3.3	35.2	41.6	55.2	-9.3
780	14.9 + j4.2	34.6	40.6	52.1	-7.7	15.5 + j2.9	34.4	41.6	54.9	-8.5
800	14.7 + j4.7	34.5	40.8	53.6	-7	15.5 + j3.3	34.3	41.7	56.3	-7.3
820	14.8 + j4.1	34.2	40.8	52.7	-5.7	15.7 + j3.4	34.1	41.7	56.3	-5.9
0.84	15.4 + j4.1	34.2	40.9	54	-4.3	16.1 + j2.5	34	41.8	56.1	-4.7
860	16.1 + j3.0	34.1	40.9	52.6	-4	16.1 + j3.0	34.1	41.8	56.3	-4.3
880	17.5 + j3.4	34.3	40.8	53.4	-4	16.0 + j2.8	34.2	41.8	55.4	-4.5
900	17.8 + j2.7	34.3	40.8	52.4	-3.7	17.9 + j1.7	34.2	41.7	54.8	-4.1
920	17.3 + j2.8	34.5	40.8	52.7	-3.6	17.3 + j1.9	34.4	41.8	55	-4.1
940	17.4 + j2.7	34.6	40.7	51.8	-4	17.3 + j1.8	34.4	41.7	54.4	-4.2
960	17.6 + j3.5	34.8	40.7	52.4	-4.1	16.8 + j2.5	34.7	41.7	54.9	-4.8
980	18.5 + j3.0	34.7	40.6	51.5	-4.5	16.9 + j2.5	34.7	41.6	54.6	-5.6
1000	19.3 + j1.9	34.2	40.6	50.3	-5	17.6 + j2.5	34.3	41.6	54.9	-6.1

Table 10. Typical impedance tuned for maximum power added efficiency

Measured load-pull data per section; test signal: pulsed CW; $T_{case} = 25\text{ }^{\circ}\text{C}$; $V_{DS} = 28\text{ V}$; $I_{Dq1} = 15\text{ mA}$; $I_{Dq2} = 60\text{ mA}$; $t_p = 100\text{ }\mu\text{s}$; $\delta = 10\text{ }\%$; $Z_S = 50\text{ }\Omega$. Typical values unless otherwise specified.

f (MHz)	at 1dB gain compression point					at 3dB gain compression point				
	Z _L (Ω)	G _{p(max)} (dB)	P _L (dBm)	η_{add} (%)	AM-PM conversion (deg)	Z _L (Ω)	G _{p(max)} (dB)	P _L (dBm)	η_{add} (%)	AM-PM conversion (deg)
BLM8G0710S-15PB										
680	21.4 + j15.6	37.4	39.7	63.9	-11.6	18.4 + j18.2	37.7	40	66.4	-14.8
700	20.7 + j20.5	38	38.8	63.7	-10.6	23.8 + j16.8	37.7	40.2	66.6	-9.6
720	20.1 + j22.8	38	38.3	63.5	-9.6	21.1 + j18.1	37.7	40	66.5	-10.1
740	18.4 + j18.1	37.6	39.1	64	-9.7	21.1 + j18.1	37.5	40	66.9	-9.3
760	21.1 + j18.1	37.1	39.1	63.8	-7.9	18.7 + j16.1	37.1	40.3	67	-10
780	21.1 + j18.1	36.8	39.1	63.3	-6.6	21.1 + j18.1	36.8	40	66.2	-6.4
800	17.9 + j20.2	36.8	38.6	62.8	-6.5	20.6 + j20.5	36.7	39.6	66.2	-4.7
820	17.8 + j20.2	36.6	38.8	63.7	-5.8	18.6 + j16.0	36.3	40.4	67.3	-5.5
840	18.2 + j18.1	36.4	39.2	64	-5.3	21.0 + j18.1	36.3	40.2	67.4	-3.4
860	18.7 + j16.1	36.2	39.7	64.3	-4.6	18.3 + j18.2	36.4	40.1	67.6	-4.2

Table 10. Typical impedance tuned for maximum power added efficiency ...continued

Measured load-pull data per section; test signal: pulsed CW; $T_{case} = 25\text{ }^{\circ}\text{C}$; $V_{DS} = 28\text{ V}$; $I_{Dq1} = 15\text{ mA}$; $I_{Dq2} = 60\text{ mA}$; $t_p = 100\text{ }\mu\text{s}$; $\delta = 10\text{ }\%$; $Z_S = 50\text{ }\Omega$. Typical values unless otherwise specified.

f	at 1dB gain compression point					at 3dB gain compression point				
	Z _L	G _{p(max)}	P _L	η_{add}	AM-PM conversion	Z _L	G _{p(max)}	P _L	η_{add}	AM-PM conversion
	(MHz)	(Ω)	(dB)	(dBm)	(%)	(deg)	(Ω)	(dB)	(dBm)	(%)
880	17.9 + j20.1	36.6	39	64.4	-4.3	17.9 + j20.1	36.6	39.8	67.3	-3.5
900	18.3 + j18.1	36.6	39.4	64.4	-3.8	16.4 + j14.9	36.4	40.7	67.1	-4.1
920	16.3 + j14.9	36.6	39.8	63.4	-4.6	18.6 + j16.0	36.5	40.5	66.2	-2.7
940	15.4 + j19.2	37	38.9	63.3	-5.5	15.9 + j17.2	36.9	40.1	65.7	-4.7
960	15.4 + j19.2	37	38.9	63.2	-5.6	15.4 + j19.2	37	39.7	66.1	-4.7
980	15.9 + j17.2	36.7	39.2	62.5	-5.6	15.9 + j17.2	36.7	40.1	65.5	-4.9
1000	13.6 + j17.6	36.6	38.7	61.4	-6.3	16.4 + j14.9	36.3	40.5	65.3	-5.5
680	21.4 + j15.6	37.4	39.7	63.9	-11.6	18.4 + j18.2	37.7	40	66.4	-14.8
700	20.7 + j20.5	38	38.8	63.7	-10.6	23.8 + j16.8	37.7	40.2	66.6	-9.6
720	20.1 + j22.8	38	38.3	63.5	-9.6	21.1 + j18.1	37.7	40	66.5	-10.1
740	18.4 + j18.1	37.6	39.1	64	-9.7	21.1 + j18.1	37.5	40	66.9	-9.3
760	21.1 + j18.1	37.1	39.1	63.8	-7.9	18.7 + j16.1	37.1	40.3	67	-10
780	21.1 + j18.1	36.8	39.1	63.3	-6.6	21.1 + j18.1	36.8	40	66.2	-6.4
BLM8G0710S-15PBG										
700	18.8 + j16.8	37.2	39.2	60.9	-11.4	19.8 + j14.0	37	40.5	63.4	-11.8
720	19.3 + j17.3	37	39.1	61.7	-9.8	19.8 + j15.2	36.9	40.4	64.4	-10.3
740	18.3 + j16.0	37.1	39.3	61.2	-9.3	19.0 + j14.7	37	40.4	63.9	-10.4
760	18.5 + j16.6	36.9	39.1	60.8	-8.7	19.7 + j17.0	36.9	40	63.6	-8.6
780	18.3 + j16.1	36.1	39.2	60.4	-8.1	18.3 + j16.1	36.1	40.1	63.2	-8.4
800	17.0 + j15.1	36	39.5	61.1	-7.7	18.0 + j15.6	36	40.3	64.1	-7.6
820	18.1 + j16.5	35.8	39.3	61.1	-6	19.0 + j16.0	35.7	40.3	64.2	-5
840	16.9 + j16.1	35.7	39.4	62.1	-5.4	17.7 + j15.6	35.6	40.4	64.8	-4.3
860	16.8 + j16.1	35.8	39.4	61.6	-4.8	15.9 + j15.7	35.8	40.2	64.1	-5.6
880	16.1 + j15.4	35.9	39.4	60.7	-5.3	15.9 + j14.7	35.8	40.4	63	-5.6
900	15.7 + j16.2	36.1	39.2	60.5	-5.1	15.6 + j15.4	36	40.2	62.9	-5
920	16.0 + j15.5	36.2	39.4	60.7	-4.6	15.9 + j14.7	36.1	40.4	63.1	-4.1
940	16.2 + j15.7	36.2	39.3	59.9	-4.6	16.0 + j14.8	36.2	40.3	62.4	-4
960	15.6 + j15.3	36.3	39.3	59.3	-4.5	15.5 + j14.4	36.3	40.3	62.3	-4.3
980	15.7 + j15.2	36.2	39.3	59.1	-4.7	14.8 + j14.7	36.2	40.2	62.5	-4
1000	14.8 + j15.6	35.8	39.1	59.2	-4.5	14.6 + j14.0	35.8	40.4	62.8	-4.5

8.4 Graphs

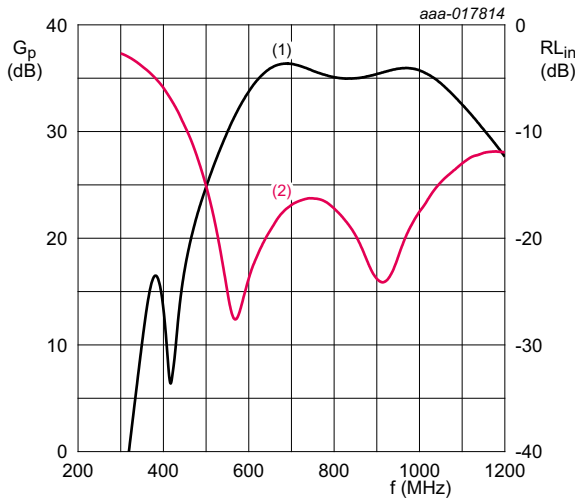

$T_{case} = 25\text{ }^{\circ}\text{C}$; $V_{DS} = 28\text{ V}$; $I_{Dq1} = 15\text{ mA}$; $I_{Dq2} = 60\text{ mA}$; $P_L = 0.2\text{ W}$. Per section.

- (1) magnitude of G_p
- (2) magnitude of RL_{in}

Fig 9. Wideband power gain and input return loss as function of frequency; typical values

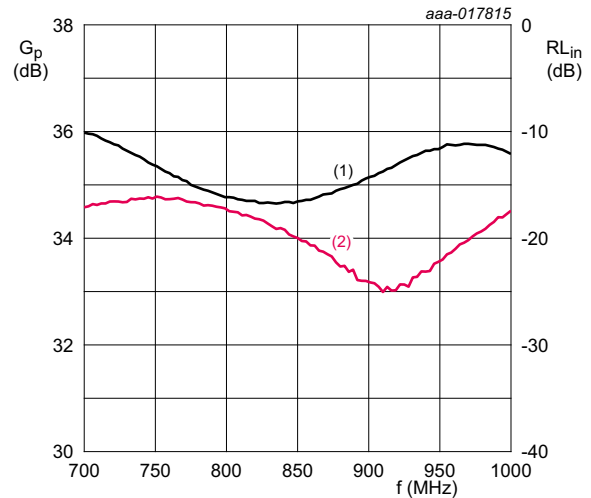

$T_{case} = 25\text{ }^{\circ}\text{C}$; $V_{DS} = 28\text{ V}$; $I_{Dq1} = 15\text{ mA}$; $I_{Dq2} = 60\text{ mA}$; $P_L = 0.2\text{ W}$. Per section.

- (1) magnitude of G_p
- (2) magnitude of RL_{in}

Fig 10. In-band power gain and input return loss as function of frequency; typical values

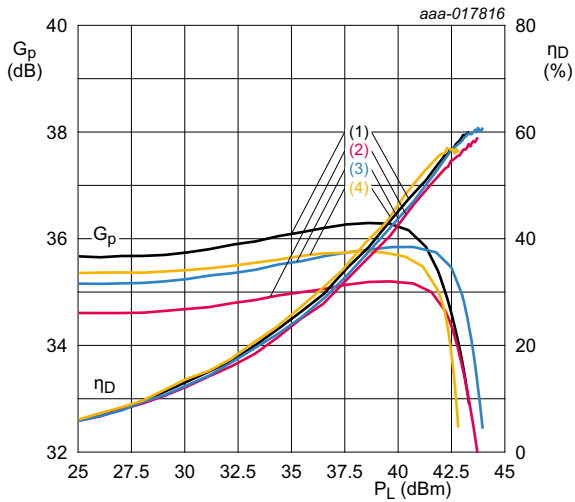

$T_{case} = 25\text{ }^{\circ}\text{C}$; $V_{DS} = 28\text{ V}$; $I_{Dq1} = 15\text{ mA}$; $I_{Dq2} = 60\text{ mA}$. Per section.

- (1) $f = 700\text{ MHz}$
- (2) $f = 800\text{ MHz}$
- (3) $f = 900\text{ MHz}$
- (4) $f = 1000\text{ MHz}$

Fig 11. Power gain and drain efficiency as function of output power; typical values

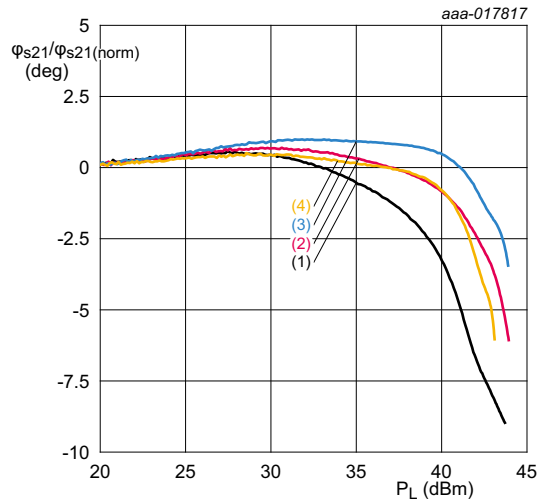

Normalized at $P_L = 26\text{ dBm}$; $T_{case} = 25\text{ }^{\circ}\text{C}$; $V_{DS} = 28\text{ V}$; $I_{Dq1} = 15\text{ mA}$; $I_{Dq2} = 60\text{ mA}$. Per section.

- (1) $f = 700\text{ MHz}$
- (2) $f = 800\text{ MHz}$
- (3) $f = 900\text{ MHz}$
- (4) $f = 1000\text{ MHz}$

Fig 12. Normalized phase response as a function of output power; typical values

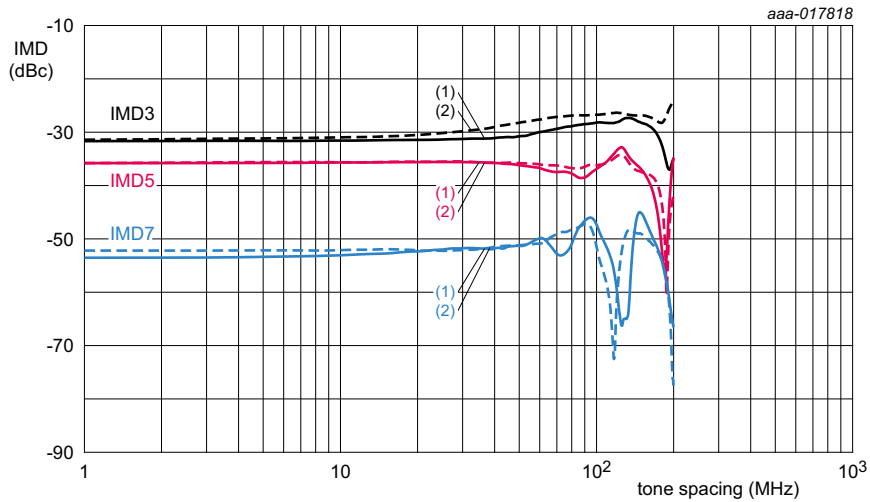

$T_{case} = 25\text{ }^{\circ}\text{C}$; $V_{DS} = 28\text{ V}$; $I_{Dq1} = 15\text{ mA}$; $I_{Dq2} = 60\text{ mA}$; $f = 881\text{ MHz}$; 2-tone CW; $P_L = 5\text{ W}$. Per section.

- (1) IMD low
- (2) IMD high

Fig 13. Intermodulation distortion as a function of tone spacing; typical values

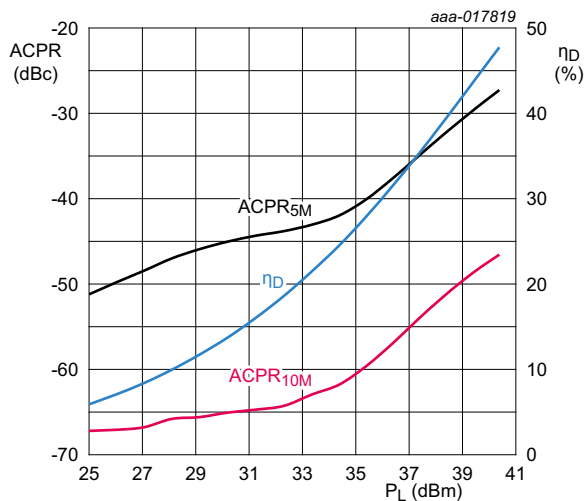

$T_{case} = 25\text{ }^{\circ}\text{C}$; $V_{DS} = 28\text{ V}$; $I_{Dq1} = 16\text{ mA}$; $I_{Dq2} = 60\text{ mA}$;
 $f = 900\text{ MHz}$; 1-carrier W-CDMA; test model 1;
 PAR = 9.9 dB at 0.01 % probability on CCDF. Per section.

Fig 14. Adjacent channel power ratio and drain efficiency as function of output power; typical values

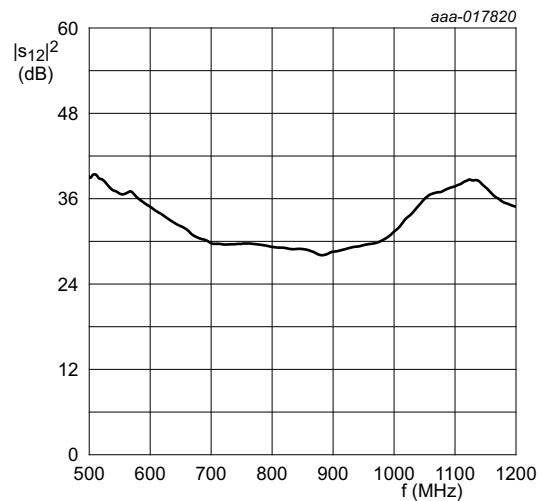

$T_{case} = 25\text{ }^{\circ}\text{C}$; $V_{DS} = 28\text{ V}$; $I_{Dq1} = 15\text{ mA}$; $I_{Dq2} = 60\text{ mA}$;
 measured on evaluation board.

Fig 15. Isolation as a function of frequency; typical values

9. Package outline

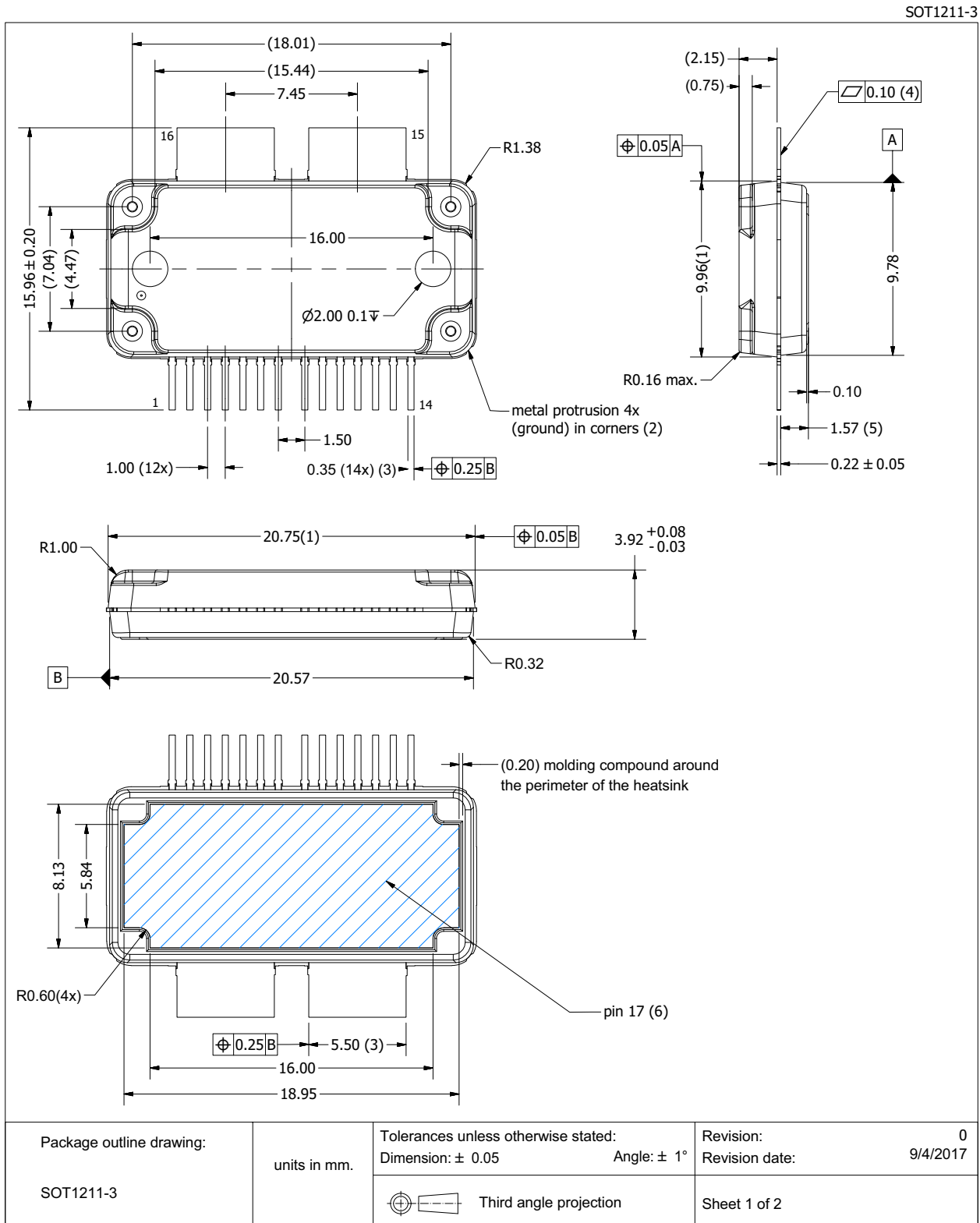

Fig 16. Package outline SOT1211-3 (sheet 1 of 2)

SOT1211-3

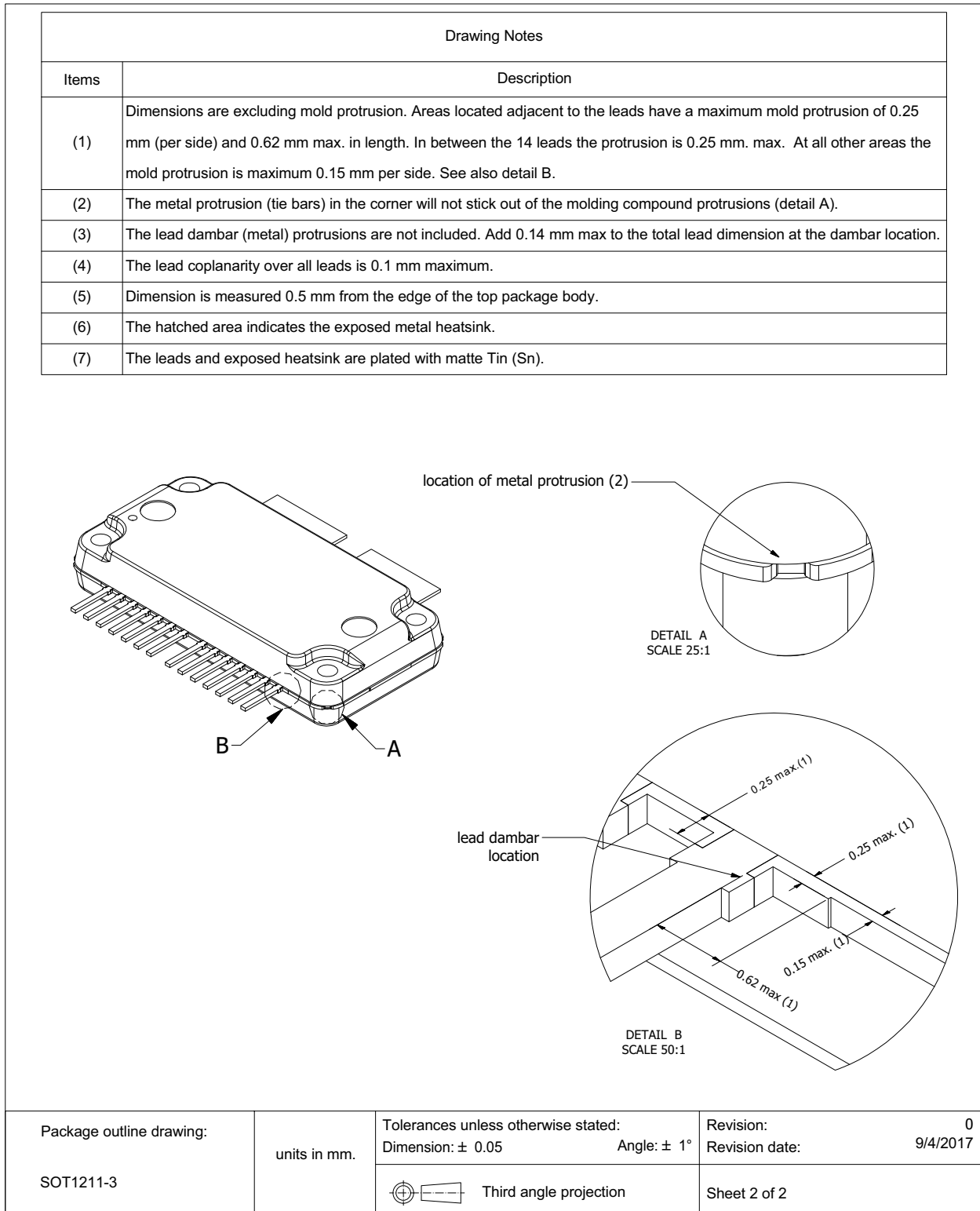

Fig 17. Package outline SOT1211-3 (sheet 2 of 2)

SOT1212-3

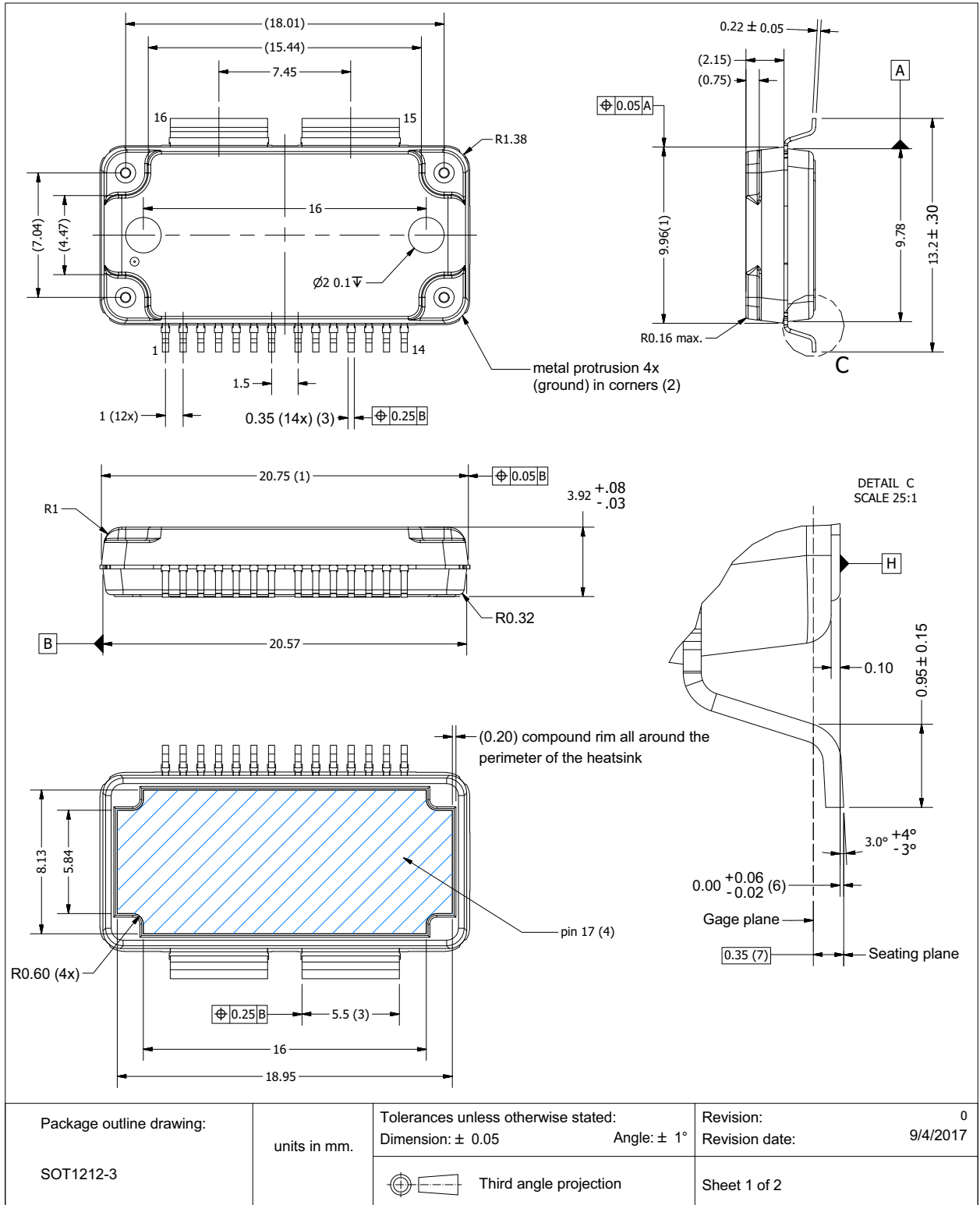

Fig 18. Package outline SOT1212-3 (sheet 1 of 2)

SOT1212-3

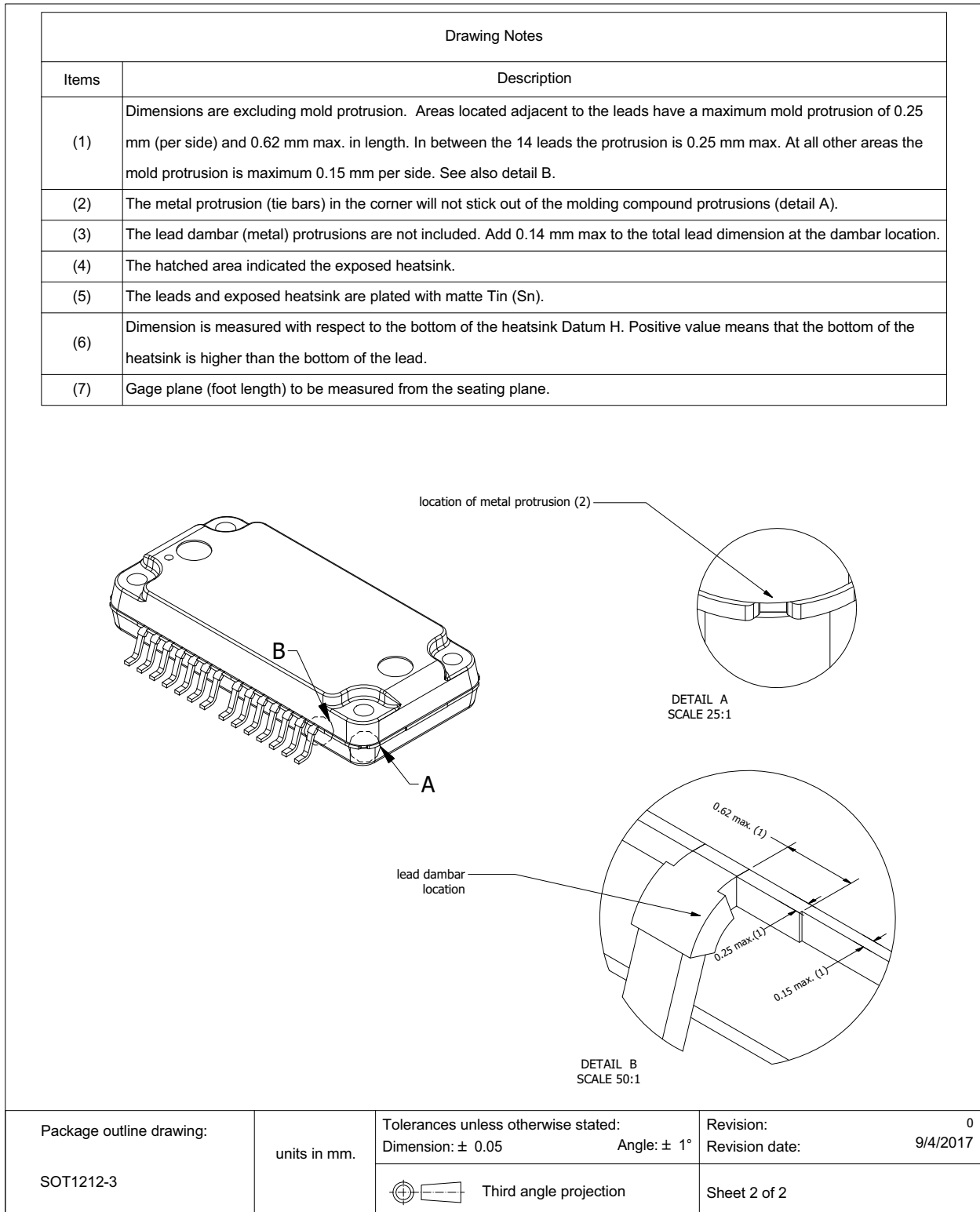

Fig 19. Package outline SOT1212-3 (sheet 2 of 2)

10. Handling information

CAUTION



This device is sensitive to ElectroStatic Discharge (ESD). Observe precautions for handling electrostatic sensitive devices.

Such precautions are described in the *ANSI/ESD S20.20*, *IEC/ST 61340-5*, *JESD625-A* or equivalent standards.

Table 11. ESD sensitivity

ESD model	Class
Charged Device Model (CDM); According to ANSI/ESDA/JEDEC standard JS-002	C0B [1]
Human Body Model (HBM); According to ANSI/ESDA/JEDEC standard JS-001	1B [2]

[1] CDM classification C0B is granted to any part that passes after exposure to an ESD pulse of 125 V, but fails after exposure to an ESD pulse of 250 V.

[2] HBM classification 1B is granted to any part that passes after exposure to an ESD pulse of 500 V, but fails after exposure to an ESD pulse of 1000 V.

11. Abbreviations

Table 12. Abbreviations

Acronym	Description
AM	Amplitude Modulation
3GPP	3rd Generation Partnership Project
CCDF	Complementary Cumulative Distribution Function
CW	Continuous Wave
DPCH	Dedicated Physical CHannel
ESD	ElectroStatic Discharge
GEN8	Eighth Generation
LDMOS	Laterally Diffused Metal Oxide Semiconductor
MMIC	Monolithic Microwave Integrated Circuit
MTF	Median Time to Failure
PAR	Peak-to-Average Ratio
PM	Phase Modulation
RoHS	Restriction of Hazardous Substances
VSWR	Voltage Standing Wave Ratio
W-CDMA	Wideband Code Division Multiple Access

12. Revision history

Table 13. Revision history

Document ID	Release date	Data sheet status	Change notice	Supersedes
BLM8G0710S-15PB_S-15PBG v.4	20180418	Product data sheet	-	BLM8G0710S-15PB_S-15PBG v.3
Modifications	<ul style="list-style-type: none"> • Figure 1 on page 2: figure updated • Table 3 on page 3: package outline versions changed to SOT1211-3 and SOT1212-3 • Figure 3 on page 6: figure updated • Figure 5 on page 8: figure updated • Figure 6 on page 8: figure updated • Figure 7 on page 8: figure updated • Figure 8 on page 9: figure updated • Table 9 on page 9: typo corrected • Table 10 on page 10: typo corrected • Section 9 on page 14: package outline versions changed from SOT1211-2 and SOT1212-2 to SOT1211-3 and SOT1212-3 • Table 11 on page 18: added table 			
BLM8G0710S-15PB_S-15PBG v.3	20150909	Product data sheet	-	BLM8G0710S-15PB_S-15PBG#2
BLM8G0710S-15PB_S-15PBG#2	20150901	Product data sheet	-	BLM8G0710S-15PB_S-15PBG v.2
BLM8G0710S-15PB_S-15PBG v.2	20150831	Product data sheet	-	BLM8G0710S-15PB_S-15PBG v.1
BLM8G0710S-15PB_S-15PBG v.1	20150702	Preliminary data sheet	-	-

13. Legal information

13.1 Data sheet status

Document status ^{[1][2]}	Product status ^[3]	Definition
Objective [short] data sheet	Development	This document contains data from the objective specification for product development.
Preliminary [short] data sheet	Qualification	This document contains data from the preliminary specification.
Product [short] data sheet	Production	This document contains the product specification.

[1] Please consult the most recently issued document before initiating or completing a design.

[2] The term 'short data sheet' is explained in section "Definitions".

[3] The product status of device(s) described in this document may have changed since this document was published and may differ in case of multiple devices. The latest product status information is available on the Internet at URL <http://www.ampleon.com>.

13.2 Definitions

Draft — The document is a draft version only. The content is still under internal review and subject to formal approval, which may result in modifications or additions. Ampleon does not give any representations or warranties as to the accuracy or completeness of information included herein and shall have no liability for the consequences of use of such information.

Short data sheet — A short data sheet is an extract from a full data sheet with the same product type number(s) and title. A short data sheet is intended for quick reference only and should not be relied upon to contain detailed and full information. For detailed and full information see the relevant full data sheet, which is available on request via the local Ampleon sales office. In case of any inconsistency or conflict with the short data sheet, the full data sheet shall prevail.

Product specification — The information and data provided in a Product data sheet shall define the specification of the product as agreed between Ampleon and its customer, unless Ampleon and customer have explicitly agreed otherwise in writing. In no event however, shall an agreement be valid in which the Ampleon product is deemed to offer functions and qualities beyond those described in the Product data sheet.

13.3 Disclaimers

Limited warranty and liability — Information in this document is believed to be accurate and reliable. However, Ampleon does not give any representations or warranties, expressed or implied, as to the accuracy or completeness of such information and shall have no liability for the consequences of use of such information. Ampleon takes no responsibility for the content in this document if provided by an information source outside of Ampleon.

In no event shall Ampleon be liable for any indirect, incidental, punitive, special or consequential damages (including - without limitation - lost profits, lost savings, business interruption, costs related to the removal or replacement of any products or rework charges) whether or not such damages are based on tort (including negligence), warranty, breach of contract or any other legal theory.

Notwithstanding any damages that customer might incur for any reason whatsoever, Ampleon's aggregate and cumulative liability towards customer for the products described herein shall be limited in accordance with the *Terms and conditions of commercial sale* of Ampleon.

Right to make changes — Ampleon reserves the right to make changes to information published in this document, including without limitation specifications and product descriptions, at any time and without notice. This document supersedes and replaces all information supplied prior to the publication hereof.

Suitability for use — Ampleon products are not designed, authorized or warranted to be suitable for use in life support, life-critical or safety-critical systems or equipment, nor in applications where failure or malfunction of an

Ampleon product can reasonably be expected to result in personal injury, death or severe property or environmental damage. Ampleon and its suppliers accept no liability for inclusion and/or use of Ampleon products in such equipment or applications and therefore such inclusion and/or use is at the customer's own risk.

Applications — Applications that are described herein for any of these products are for illustrative purposes only. Ampleon makes no representation or warranty that such applications will be suitable for the specified use without further testing or modification.

Customers are responsible for the design and operation of their applications and products using Ampleon products, and Ampleon accepts no liability for any assistance with applications or customer product design. It is customer's sole responsibility to determine whether the Ampleon product is suitable and fit for the customer's applications and products planned, as well as for the planned application and use of customer's third party customer(s). Customers should provide appropriate design and operating safeguards to minimize the risks associated with their applications and products.

Ampleon does not accept any liability related to any default, damage, costs or problem which is based on any weakness or default in the customer's applications or products, or the application or use by customer's third party customer(s). Customer is responsible for doing all necessary testing for the customer's applications and products using Ampleon products in order to avoid a default of the applications and the products or of the application or use by customer's third party customer(s). Ampleon does not accept any liability in this respect.

Limiting values — Stress above one or more limiting values (as defined in the Absolute Maximum Ratings System of IEC 60134) will cause permanent damage to the device. Limiting values are stress ratings only and (proper) operation of the device at these or any other conditions above those given in the Recommended operating conditions section (if present) or the Characteristics sections of this document is not warranted. Constant or repeated exposure to limiting values will permanently and irreversibly affect the quality and reliability of the device.

Terms and conditions of commercial sale — Ampleon products are sold subject to the general terms and conditions of commercial sale, as published at <http://www.ampleon.com/terms>, unless otherwise agreed in a valid written individual agreement. In case an individual agreement is concluded only the terms and conditions of the respective agreement shall apply. Ampleon hereby expressly objects to applying the customer's general terms and conditions with regard to the purchase of Ampleon products by customer.

No offer to sell or license — Nothing in this document may be interpreted or construed as an offer to sell products that is open for acceptance or the grant, conveyance or implication of any license under any copyrights, patents or other industrial or intellectual property rights.

Export control — This document as well as the item(s) described herein may be subject to export control regulations. Export might require a prior authorization from competent authorities.

Non-automotive qualified products — Unless this data sheet expressly states that this specific Ampleon product is automotive qualified, the product is not suitable for automotive use. It is neither qualified nor tested in accordance with automotive testing or application requirements. Ampleon accepts no liability for inclusion and/or use of non-automotive qualified products in automotive equipment or applications.

In the event that customer uses the product for design-in and use in automotive applications to automotive specifications and standards, customer (a) shall use the product without Ampleon's warranty of the product for such automotive applications, use and specifications, and (b) whenever customer uses the product for automotive applications beyond Ampleon's specifications such use shall be solely at customer's own risk, and (c) customer fully indemnifies Ampleon for any liability, damages or failed product claims resulting from customer design and use of the product for automotive applications beyond Ampleon's standard warranty and Ampleon's product specifications.

Translations — A non-English (translated) version of a document is for reference only. The English version shall prevail in case of any discrepancy between the translated and English versions.

13.4 Trademarks

Notice: All referenced brands, product names, service names and trademarks are the property of their respective owners.

Any reference or use of any 'NXP' trademark in this document or in or on the surface of Ampleon products does not result in any claim, liability or entitlement vis-à-vis the owner of this trademark. Ampleon is no longer part of the NXP group of companies and any reference to or use of the 'NXP' trademarks will be replaced by reference to or use of Ampleon's own trademarks.

14. Contact information

For more information, please visit: <http://www.ampleon.com>

For sales office addresses, please visit: <http://www.ampleon.com/sales>

15. Contents

1 Product profile 1

1.1 General description 1

1.2 Features and benefits 1

1.3 Applications 1

2 Pinning information 2

2.1 Pinning 2

2.2 Pin description 2

3 Ordering information 3

4 Block diagram 3

5 Limiting values 3

6 Thermal characteristics 4

7 Characteristics 4

8 Application information 5

8.1 Possible circuit topologies 8

8.2 Ruggedness in class-AB operation 9

8.3 Impedance information 9

8.4 Graphs 12

9 Package outline 14

10 Handling information 18

11 Abbreviations 18

12 Revision history 19

13 Legal information 20

13.1 Data sheet status 20

13.2 Definitions 20

13.3 Disclaimers 20

13.4 Trademarks 21

14 Contact information 21

15 Contents 22

Please be aware that important notices concerning this document and the product(s) described herein, have been included in section 'Legal information'.

© Ampleon Netherlands B.V. 2018. All rights reserved.

For more information, please visit: <http://www.ampleon.com>
 For sales office addresses, please visit: <http://www.ampleon.com/sales>

Date of release: 18 April 2018

Document identifier: BLM8G0710S-15PB_S-15PBG