

- **Avalanche Energy Specified**
- **Fast Switching**
- **Simple Drive Requirements**

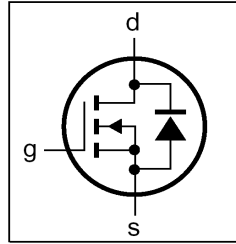

<b><math>BV_{DSS}</math></b>	<b>600V</b>
<b><math>R_{DS(ON)}</math></b>	<b>4.4Ω</b>
<b><math>I_D</math></b>	<b>2A</b>

### Description

This advanced high voltage MOSFET is produced using Belling's proprietary DMOS technology. Designed for high efficiency switch mode power supply.

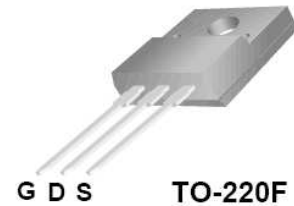

### Absolute Maximum Ratings ( $T_C=25^{\circ}C$ unless otherwise noted )

Symbol	Parameter	Value	Units
$V_{DS}$	Drain-Source Voltage	600	V
$V_{GS}$	Gate-Source Voltage	$\pm 30$	V
$I_D$	Continuous Drain Current	2	A
	Continuous Drain Current ( $T_C=100^{\circ}C$ )	1.26	A
$I_{DM}$	Drain Current (pulsed) (Note 1)	8	A
$P_D$	Power Dissipation	23	W
	Linear Derating Factor	0.18	W/ $^{\circ}C$
$E_{AS}$	Single Pulsed Avalanche Energy (Note 2)	40	mJ
$I_{AR}$	Avalanche Current (Note 1)	2	A
$E_{AR}$	Repetitive Avalanche Energy (Note 1)	2.3	mJ
$T_j$	Operating Junction Temperature Range	-55 to +150	$^{\circ}C$
$T_{SDG}$	Storage Temperature Range	-55 to +150	$^{\circ}C$

### Thermal Characteristics

Symbol	Parameter	Value	Units
$R_{thj-c}$	Thermal Resistance, Junction to Case Max.	5.5	$^{\circ}C/W$
$R_{thj-a}$	Thermal Resistance, Junction to Ambient Max.	62.5	$^{\circ}C/W$

**Electrical Characteristics** (  $T_C=25^\circ\text{C}$  unless otherwise noted )

Symbol	Parameter	Test Conditions	Min.	Typ.	Max.	Units
$BV_{DSS}$	Drain-Source Breakdown Voltage	$V_{GS}=0V, I_D=250\mu A$	600	-	-	V
$\Delta BV_{DSS} / \Delta T_J$	Breakdown Voltage Temperature Coefficient	Reference to $25^\circ\text{C}$ , $I_D=250\mu A$	-	0.6	-	V/ $^\circ\text{C}$
$R_{DS(ON)}$	Static Drain-Source On-Resistance	$V_{GS}=10V, I_D=1A$	-	-	4.4	$\Omega$
$V_{GS(th)}$	Gate Threshold Voltage	$V_{DS}=V_{GS}, I_D=250\mu A$	2	-	4	V
$g_{fs}$	Forward Transconductance (note3)	$V_{DS}=15V, I_D=1A$	-	1.5	-	S
$I_{DSS}$	Drain-Source Leakage Current	$V_{DS}=600V, V_{GS}=0V$	-	-	1	$\mu A$
	Drain-Source Leakage Current $T_C=125^\circ\text{C}$	$V_{DS}=480V, V_{GS}=0V$	-	-	100	$\mu A$
$I_{GSS}$	Gate-Source Leakage Current	$V_{GS}=\pm 30V$	-	-	$\pm 100$	nA
$Q_g$	Total Gate Charge	$V_{DD}=480V$ $I_D=2A$ $V_{GS}=10V$	-	15.4	-	nC
$Q_{gs}$	Gate-Source Charge	(note3)	-	2	-	nC
$Q_{gd}$	Gate-Drain Charge		-	8.2	-	nC
$t_{(on)}$	Turn-on Delay Time		$V_{DD}=300V$ $I_D=2A$ $R_G=25\Omega$ note3	-	8.7	-
$t_r$	Turn-on Rise Time	(note3)	-	11.6	-	ns
$t_{(off)}$	Turn-off Delay Time		-	24.5	-	ns
$t_f$	Turn-off Fall Time		-	23.4	-	ns
$C_{iss}$	Input Capacitance	$V_{DS}=25V$ $V_{GS}=0V$ $f=1\text{MHz}$	-	365	-	pF
$C_{oss}$	Output Capacitance		-	33	-	pF
$C_{rss}$	Reverse Transfer Capacitance		-	9.6	-	pF

**Source-Drain Diode Characteristics**

Symbol	Parameter	Test Conditions	Min.	Typ.	Max.	Units
$I_S$	Continuous Source Diode Forward Current		-	-	2	A
$I_{SM}$	Pulsed Source Diode Forward Current (note1)		-	-	8	A
$V_{SD}$	Forward On Voltage	$V_{GS}=0V, I_S=2A$	-	-	1.8	V
$t_{rr}$	Reverse Recovery Time	$V_{GS}=0V, I_S=2A(\text{note3})$	-	360	-	ns
$Q_{rr}$	Reverse Recovery Charge	$di_F/dt = 100A/\mu s$	-	1	-	$\mu C$

**Note:**

- (1) Repetitive Rating: Pulse width limited by maximum junction temperature
- (2)  $L=25\text{mH}$ ,  $I_{as}=1.7A$ ,  $V_{dd}=50V$ ,  $R_g=25\Omega$ , starting  $T_j=25^\circ\text{C}$
- (3) Pulse width  $\leq 300\mu s$ ; duty cycle  $\leq 2\%$

**Typical Characteristics**

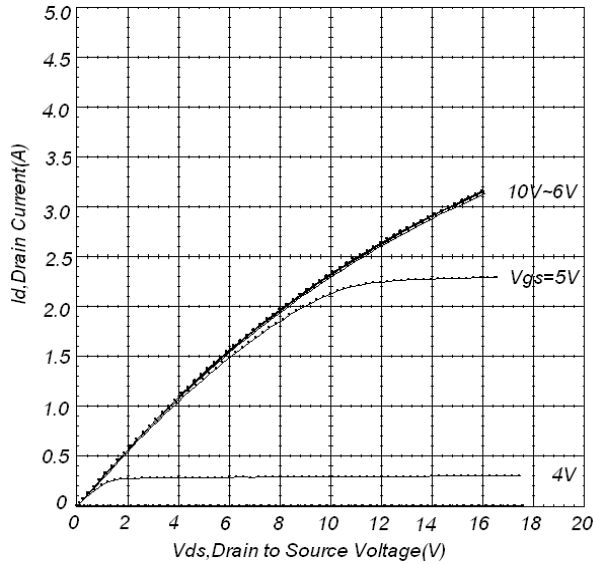

Fig 1. Typical Output Characteristics

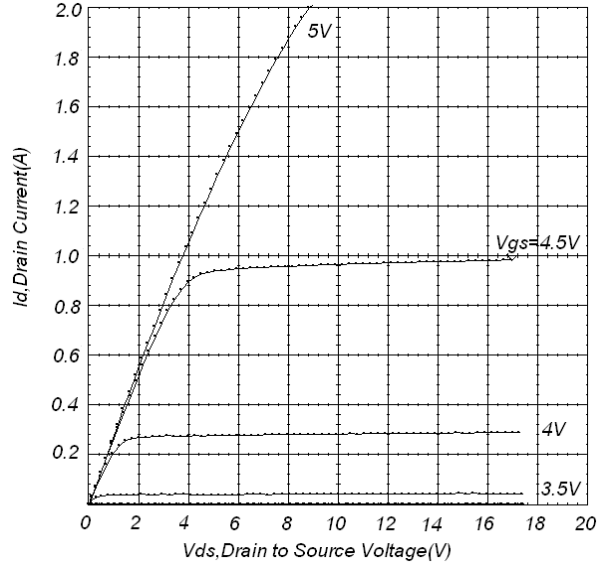

Fig 2. Typical Output Characteristics

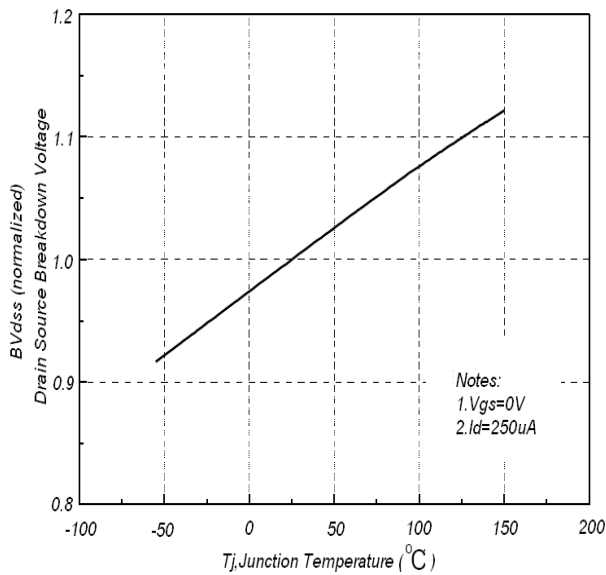

Fig 3. Normalized BVdss vs. Junction Temperature

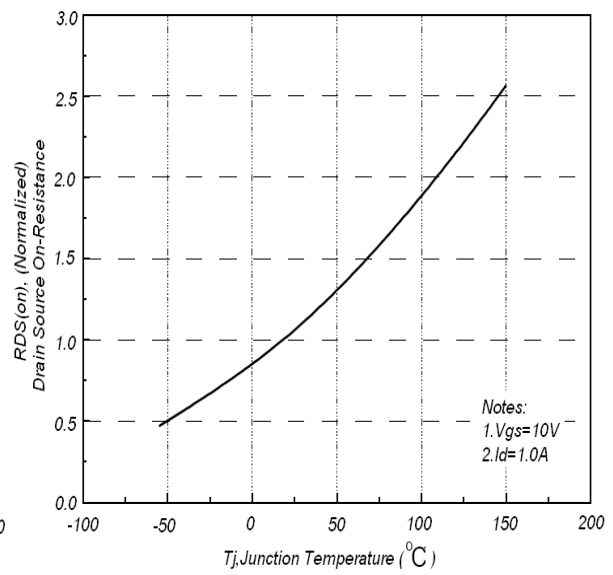
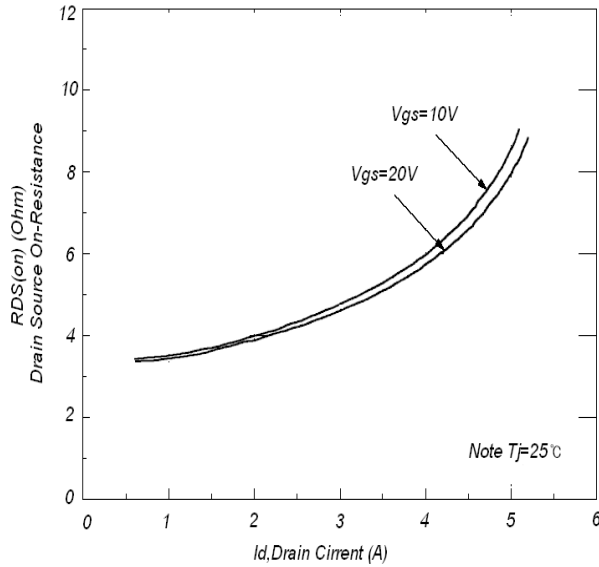
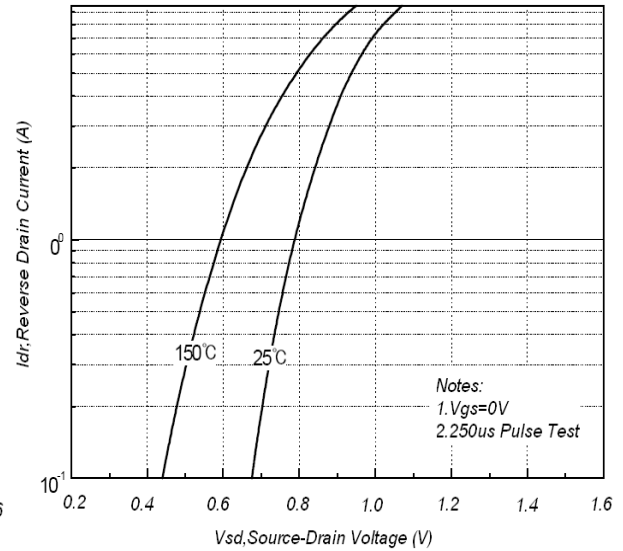

Fig 4. Normalized On-Resistance vs. Junction Temperature

**Typical Characteristics (continued)**



**Fig 5. On-Resistance Variation vs. Drain Current and Gate Voltage**



**Fig 6. Body Diode Forward Voltage Variation vs. Source Current and Temperature**

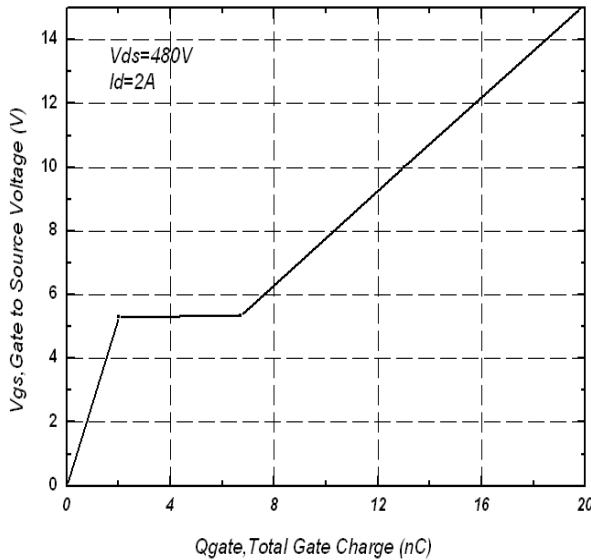

**Fig 7. Gate Charge Characteristics**

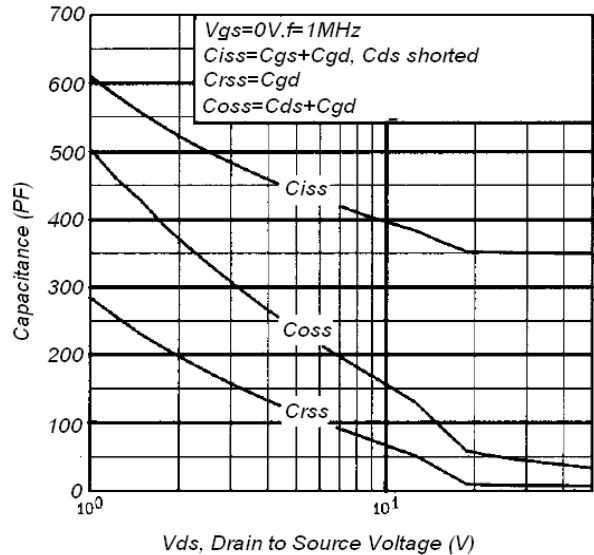

**Fig 8. Capacitance Characteristics**

**Typical Characteristics (continued)**

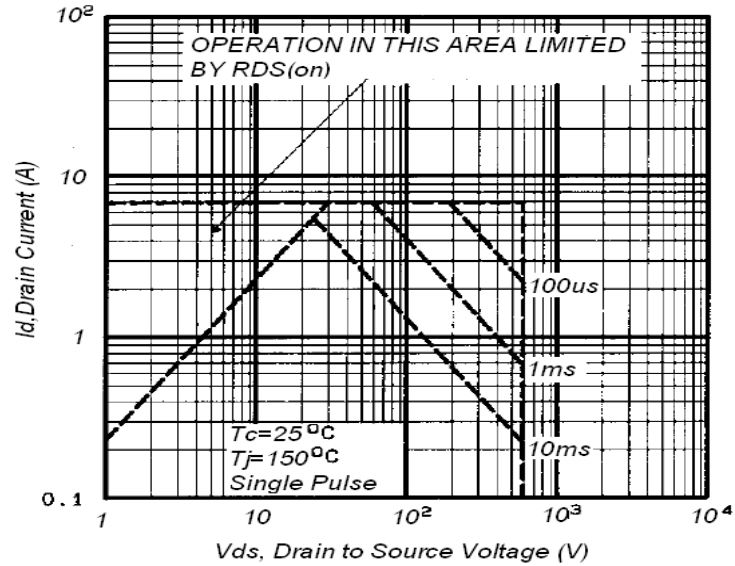

Fig 9. Maximum Safe Operating Area

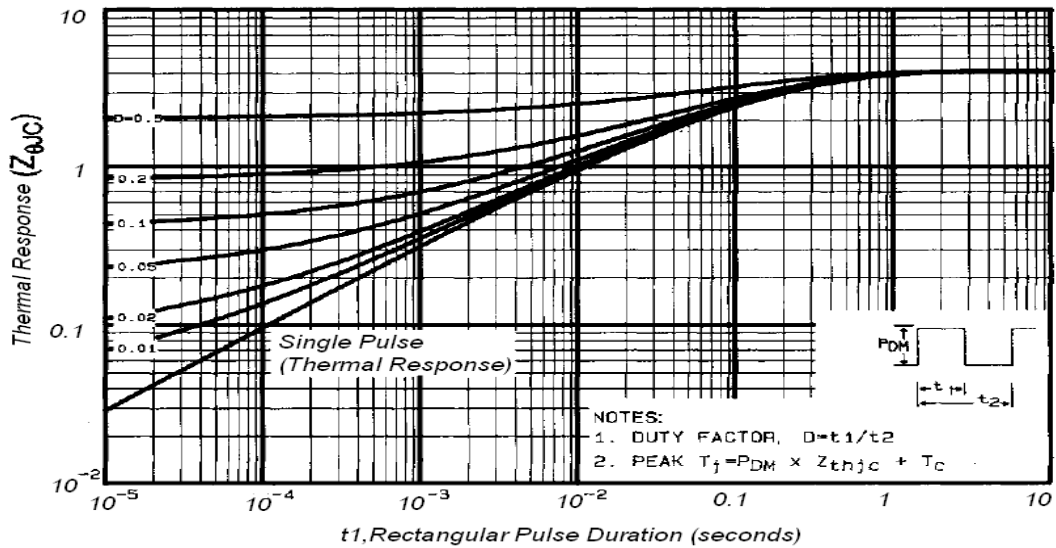

Fig 10. Transient Thermal Response Curve

**Test Circuit and Waveform**

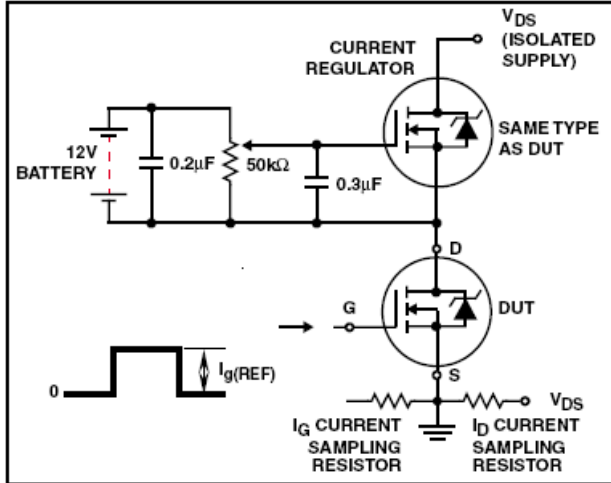

Fig 11. Gate Charge Circuit

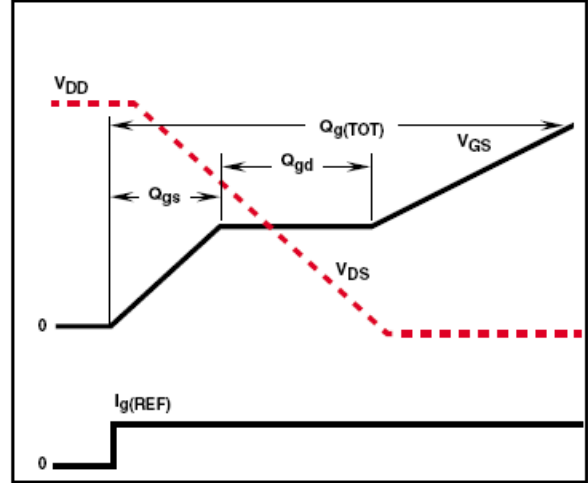

Fig 12. Gate Charge Waveform

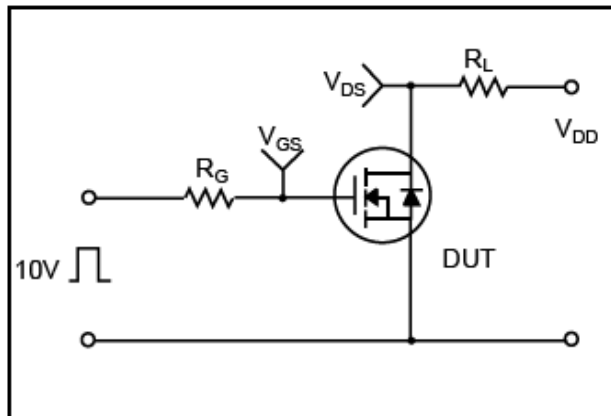

Fig 13. Switching Time Circuit

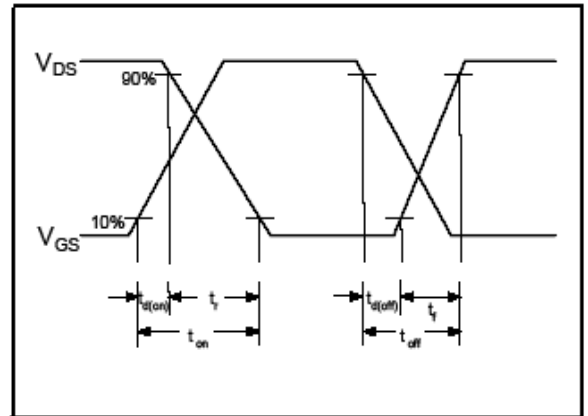

Fig 14. Switching Time Waveform

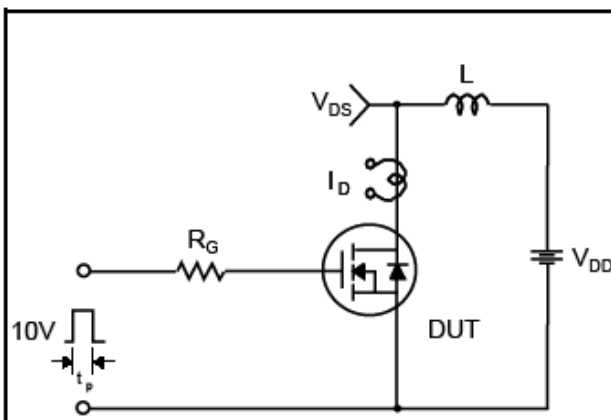

Fig 15. Unclamped Inductive Switching Test Circuit

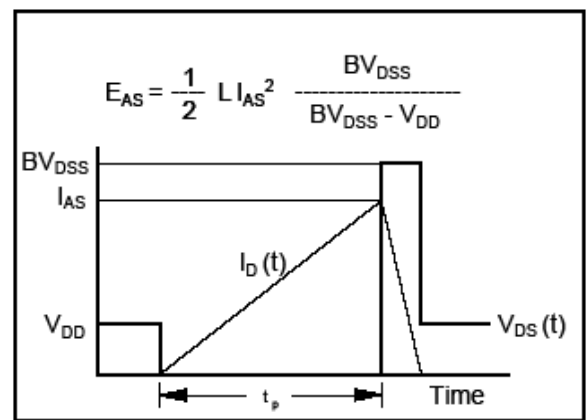

Fig 16. Unclamped Inductive Switching Waveforms