

## White LED Step-Up Converter

BM0246A is a step-up DC/DC converter specifically designed to drive white LED with a constant current. It can drive two, three, or four LEDs. It switches at 1.4MHz and use tiny external components. The output capacitor can be as small as 0.22uF, which can save space and cost versus alternative solutions. Feedback voltage is as low as 105mV. Built-in OverVoltage function.

- OverVoltage Function
- Fast 1.4MHz Switching Frequency
- Requires Only 0.22uF Output Capacitor
- Inherently Matched LED Current
- High Efficiency: 90% Typical
- 2.5V to 16V  $V_{IN}$  ranges
- Drives Up to Four series LEDs with a Li-Ion cell
- PIN TO PIN with **RT9271** and **AIC1896, D246**
- SOT-26 Package

### Absolute maximum ratings

Parameter	symbol	value	unit
Supply Voltage	$V_{IN}$	15	V
Feedback Voltage	FB	10	V
Switch Voltage	SW	30	V
CE Voltage	$V_{CE}$	10	V
Operating temperature range	$T_{opr}$	-25 to +85	°C
Storage temperature range	$R_{stg}$	-55 to +150	°C
Junction temperature	$T_j$	125	°C

### Pin name

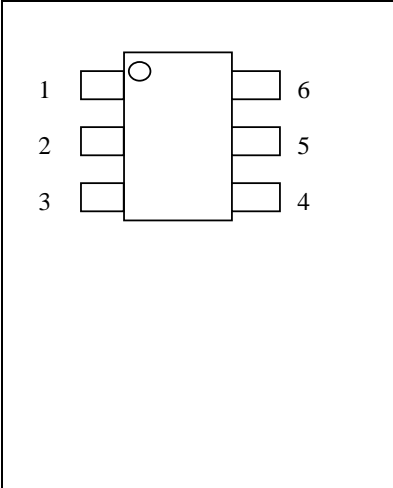
	Description	Symbol	Description	Symbol
	1: Switch	SW	6: Supply Voltage	$V_{IN}$
	2: GND	GND	5: Over Voltage	OVP
	3: Feedback	FB	4: Start-Up	CE

# BOOST IC (LED DRIVER)

# BM0246A

## Block Diagram

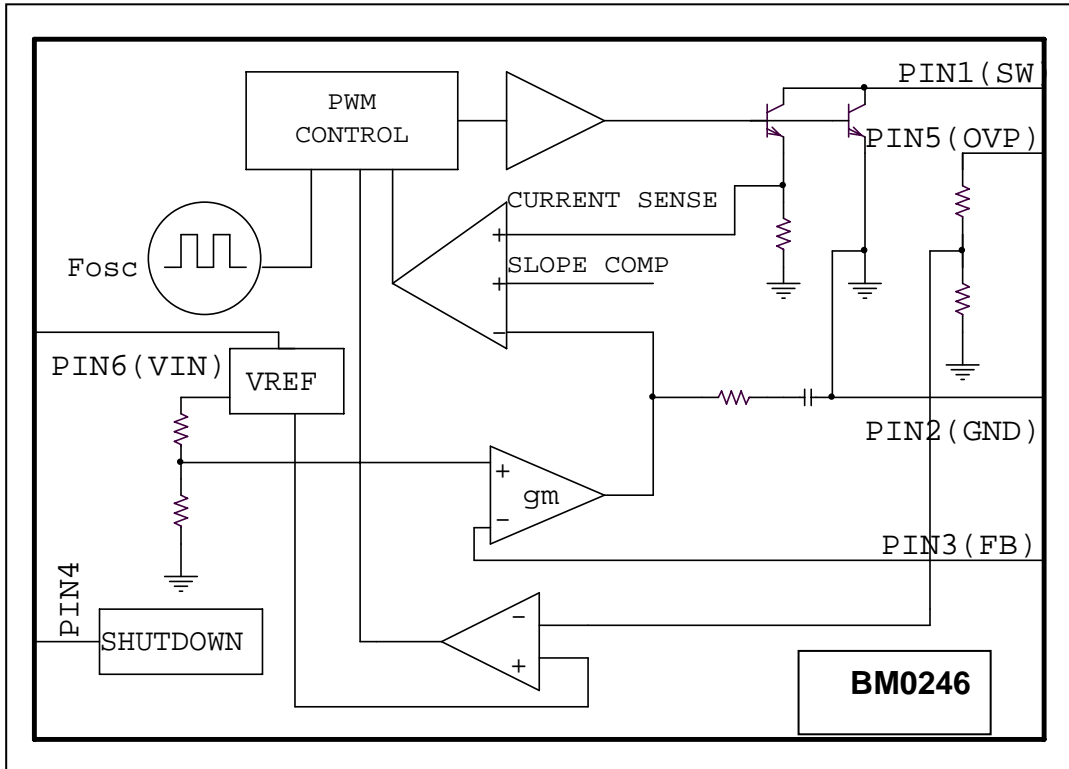

# BOOST IC (LED DRIVER)

# BM0246A

## Electrical Characteristics

T<sub>amb</sub> = 25°C, V<sub>IN</sub>=3V, V<sub>CE</sub>=3V, unless otherwise specified.

Parameter	Test Conditions / Pins	Min	Type	Max	Unit
Minimum Operating Voltage		2.5			V
Maximum Operating Voltage				10	V
Feedback Voltage	I <sub>SW</sub> =100mA, Duty Cycle=66%	104	115	126	mV
FB Pin Bias Current		50	100	200	nA
Supply Current	V <sub>CE</sub> =0V		1.9 0.1	2.5 1	mA uA
Switching Frequency		0.8	1.0	1.2	MHz
Maximum Duty Cycle		85	90		%
OVP Protection			21		V
Switch Current Limit			320		mA
Switch V <sub>CESAT</sub>	I <sub>SW</sub> =250mA		350		mV
Switch Leakage Current	V <sub>SW</sub> =5V		0.01	5	uA
CE Voltage High		1.5			V
CE Voltage Low				0.4	V
CE Pin Bias Current			65		uA

## Typical Application

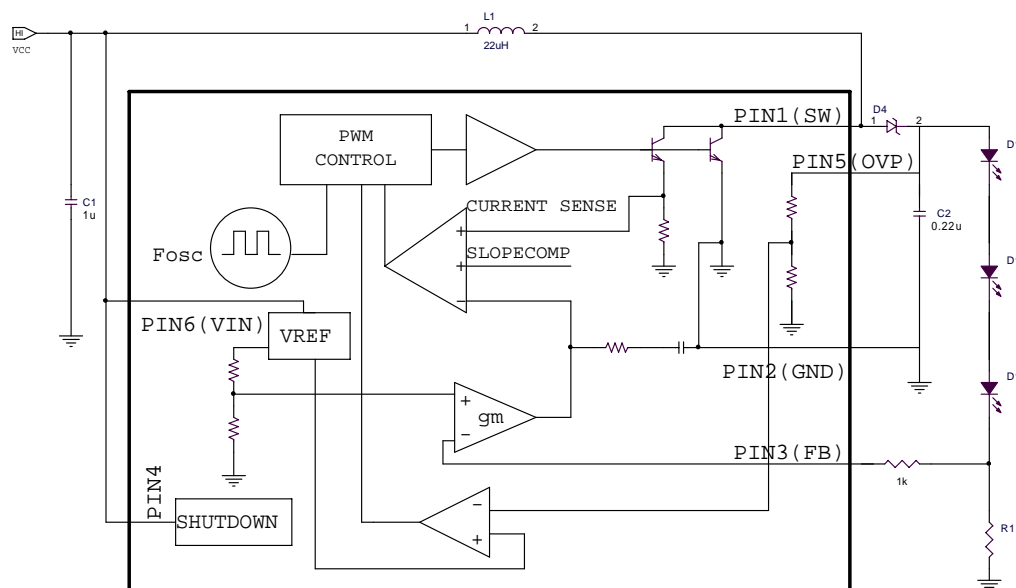

# BOOST IC (LED DRIVER)

# BM0246A

## Analog Voltage Light Control

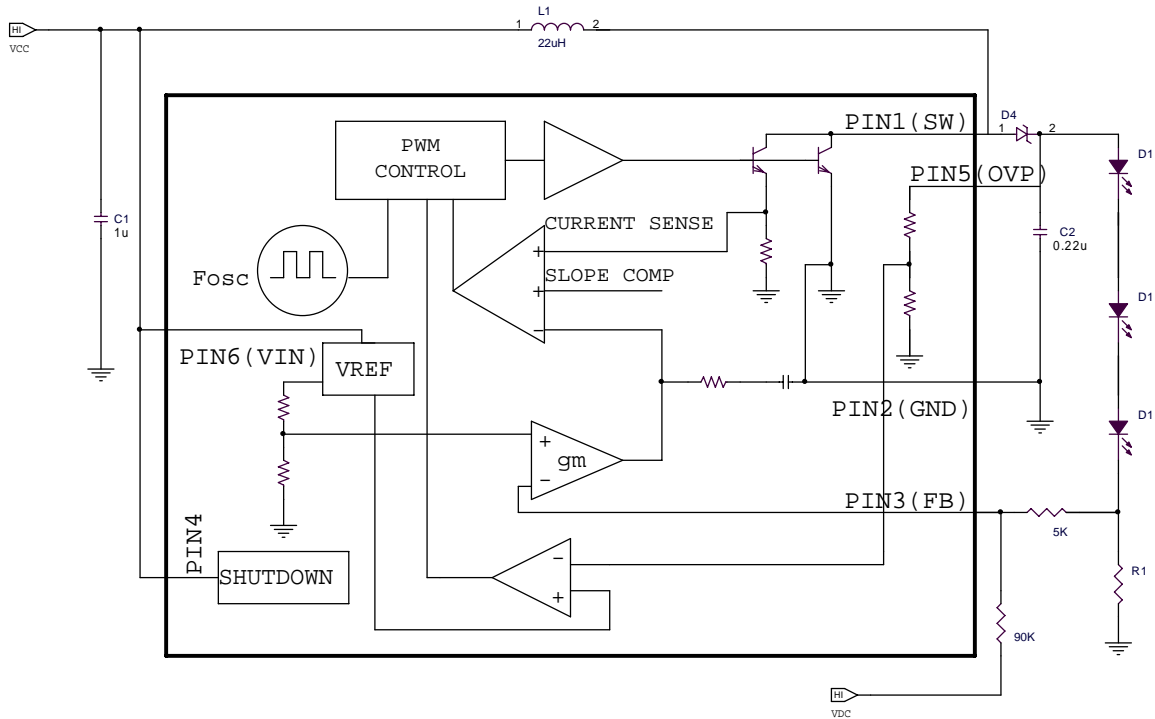

## Logic Voltage Light Control

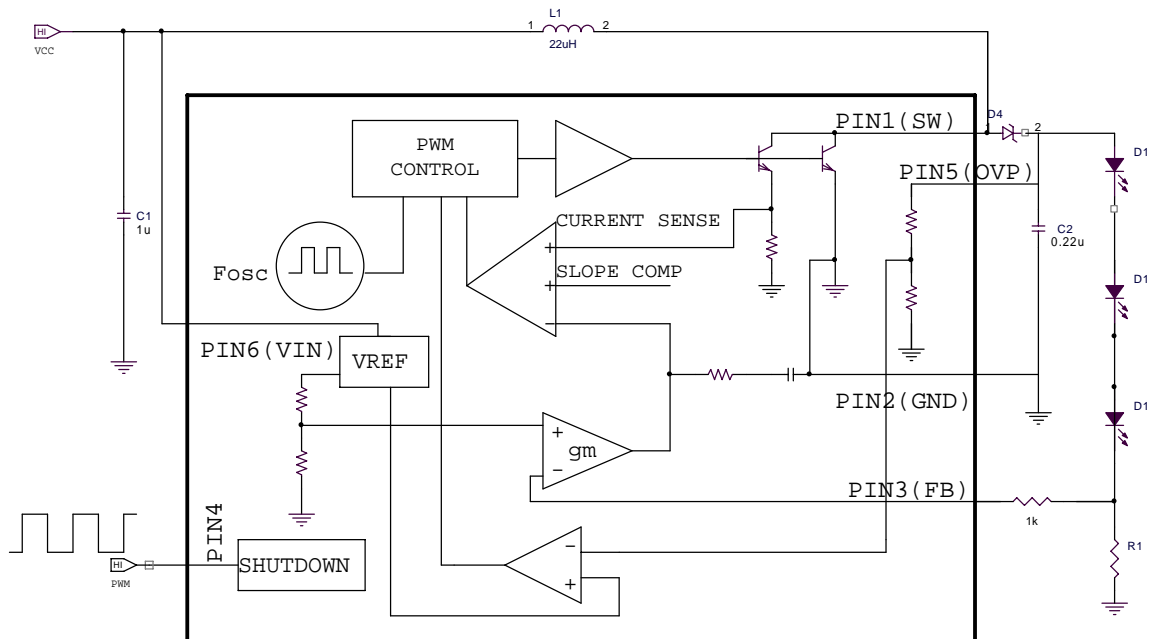

Figure

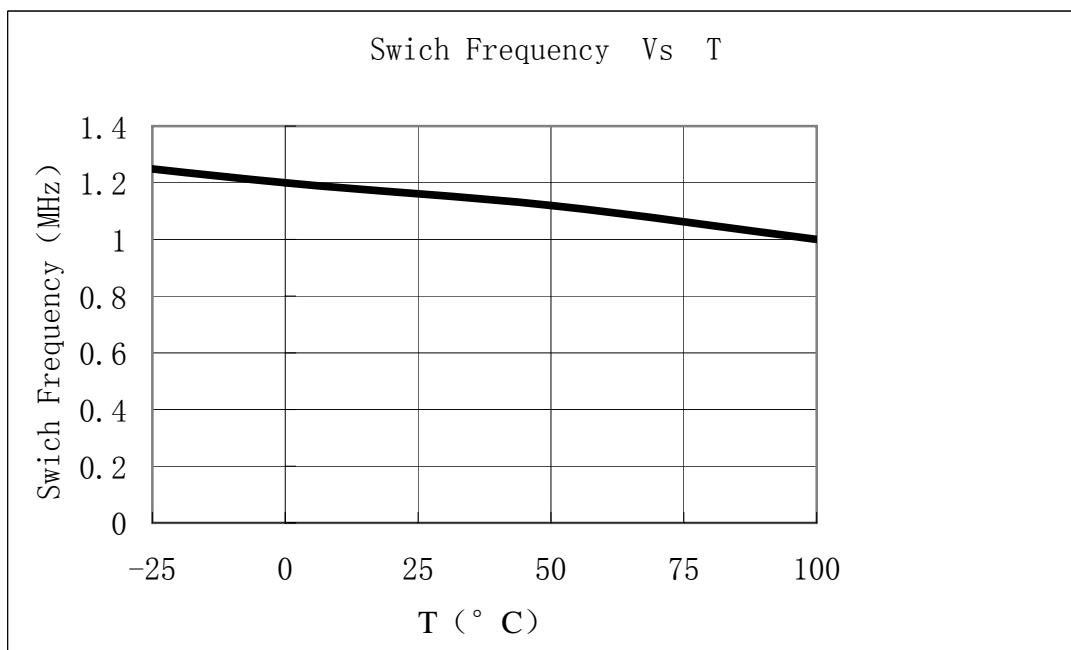
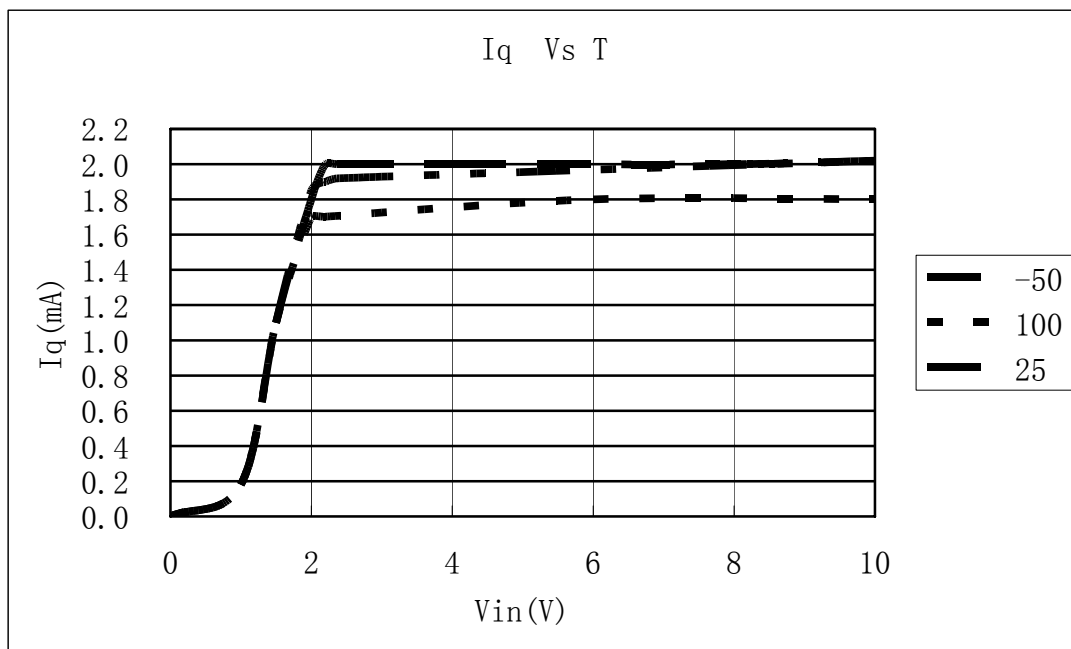

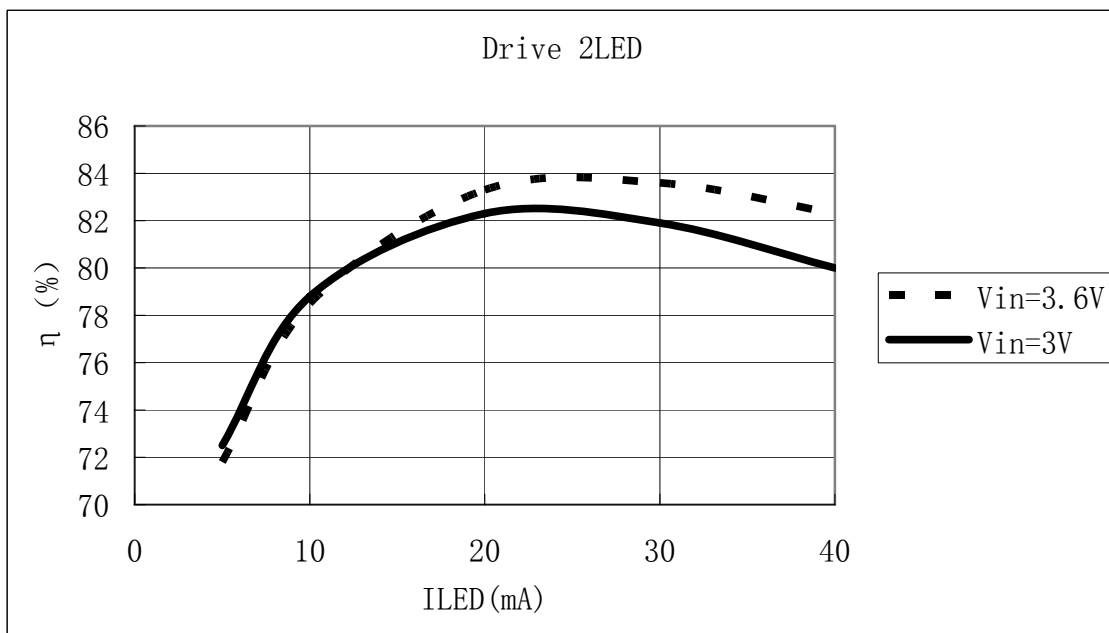
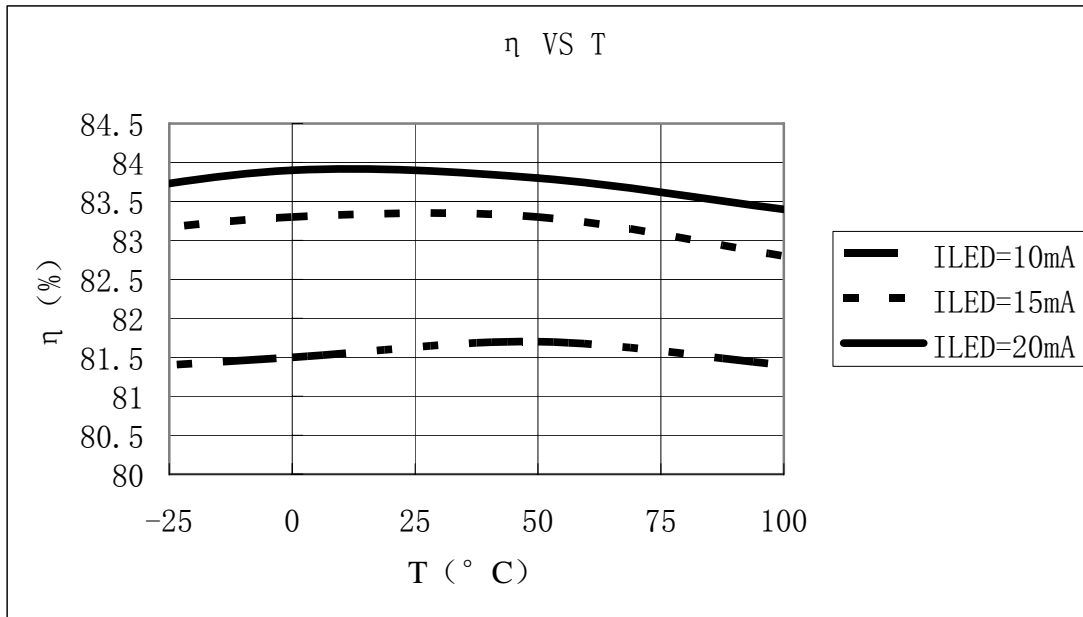

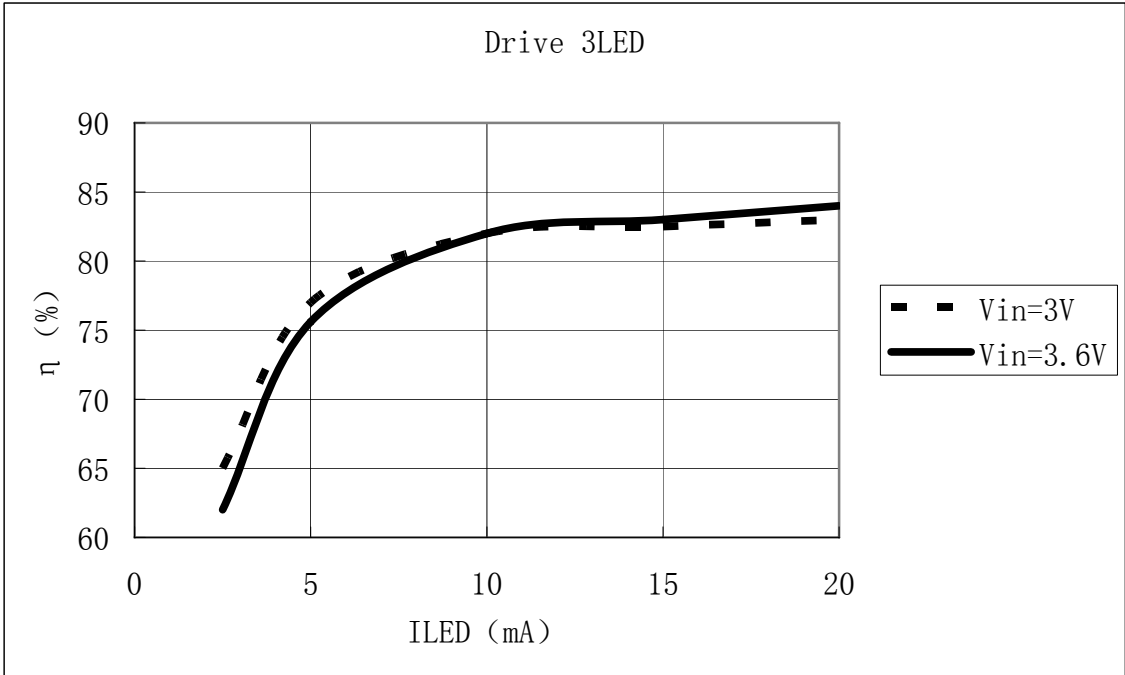

# BOOST IC (LED DRIVER)

# BM0246A

## SOT-26 Diagram

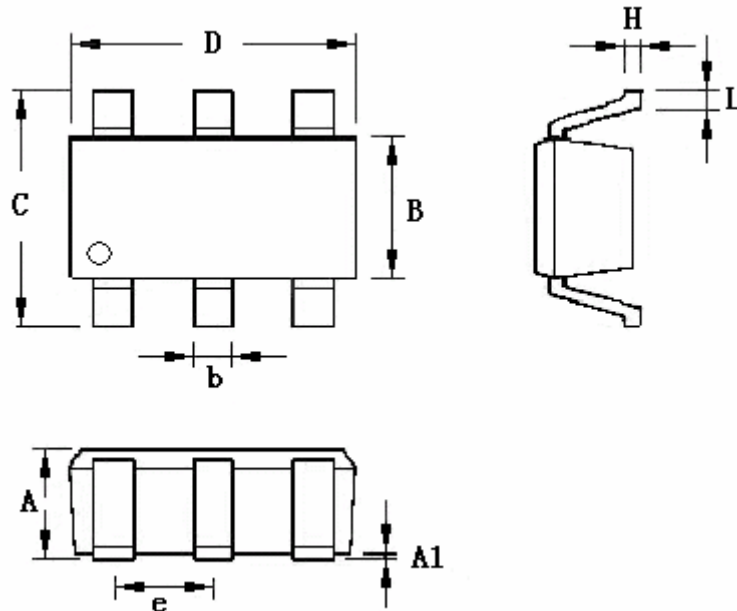

Symbol	Dimension(in mm)		Dimension(in Inch)	
	min	max	min	max
A	0.787	1.450	0.031	0.057
A1		0.152		0.006
B	1.397	1.803	0.055	0.071
b	0.250	0.559	0.010	0.022
C	2.591	2.997	0.102	0.118
D	2.692	3.099	0.106	0.122
E	0.838	1.041	0.033	0.041
H	0.080	0.254	0.003	0.010
L	0.300	0.610	0.012	0.024