

BM0550HV

Universal High Brightness LED Driver

DESCRIPTION

The BM0550HV is a high efficiency LED driver. It operates in wide range input voltage from 10V up to 600V. The device drives an external MOSFET at a fixed frequency. The frequency is programmable up to 280KHz with a single resistor. The dimming control for chip can be either PWM input or linear input. The LED string is driven at a constant current without the need for loop compensation. BM0550HV requires only few external components to achieve constant LED current making it ideas for low cost LED driver. The chip is available in SOP-8 package.

APPLICATIONS

- AC/DC or DC/DC LED driver applications
- Backlighting for flat panel displays
- General purpose constant current source
- Automotive
- Chargers

FEATURES

- >90% efficiency
- 10V to 600V DC input range
- Constant current LED driver
- Linear and PWM dimming capability
- Internal thermal overload protection

PIN CONFIGURATION(SOP-8)

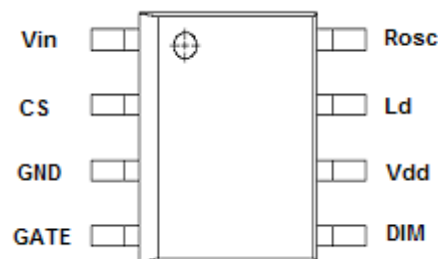

PART MARKING

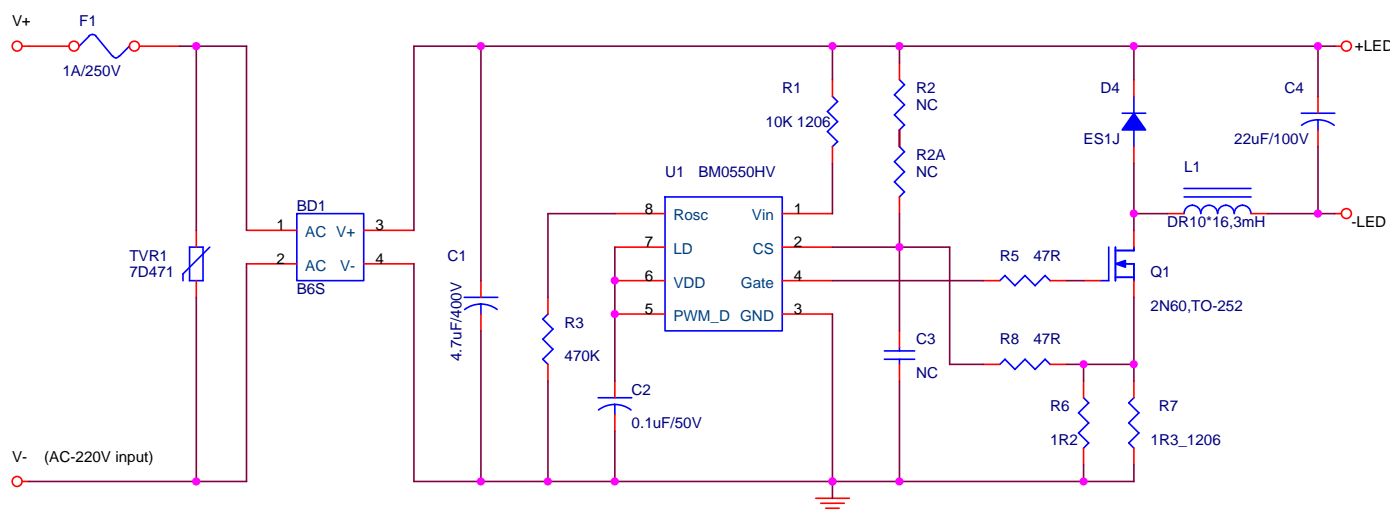

BM0550HV

Universal High Brightness LED Driver

TYPICAL APPLICATION CIRCUIT

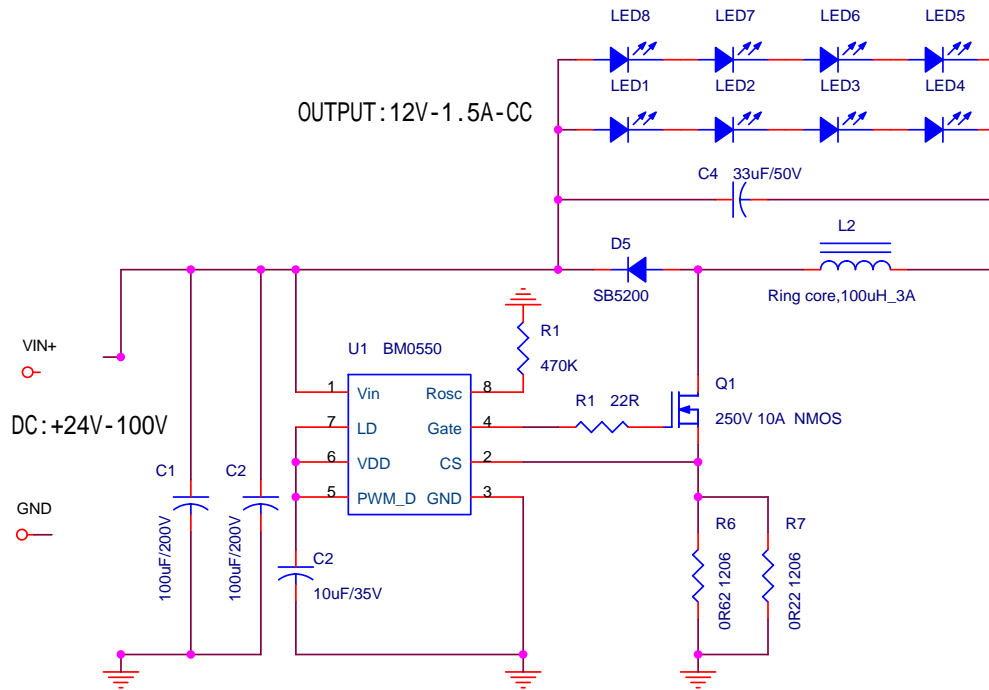

$V_{out} / V_{in} < 0.5$ 应用图

1	VIN	Supply Voltage Input
2	CS	Current sense. This pin senses the voltage across a resistor, to control PWM output. This pin also provides current amplitude information for current-mode control
3	GND	Ground
4	Gate	Gate driver output to drive the external MOSFET
5	Dim	Dimming Control
6	Vdd	Power supply pin for internal circuits
7	Ld	Linear dimming by changing the current limit threshold at current sense comparator
8	Rosc	This is used to charge an internal capacitor, to determine the switching frequency

ORDERING INFORMATION

Part Number	Package	Part Marking
BM0550HV	SOP-8	BM0550HV

※ Tape Reel ; Halogen -Free

BM0550HV

Universal High Brightness LED Driver

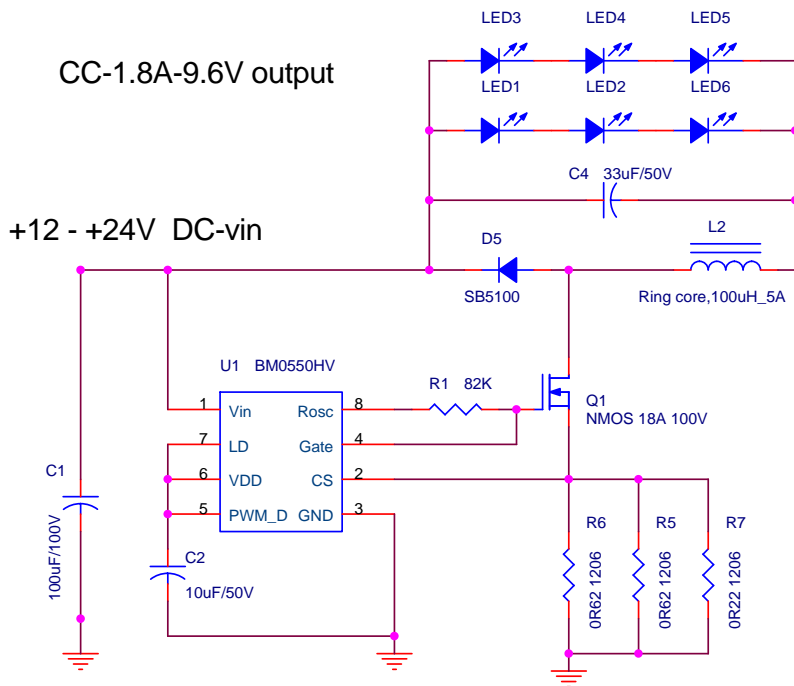

Vout / Vin > 0.5 应用图

ABSOLUTE MAXIMUM RATINGS

(T_A=25°C Unless otherwise specified)

Parameter	Symbol	Value	Unit
DC Supply Voltage	V _{IN}	600	V
Vdd to Ground	Vdd	12	V
CS, Gate, Dim, Ld		Vdd+0.3V	V
Operating Temperature	T _{OPR}	-40~85	°C
Maximum Junction Temperature	T _{J(Max)}	-40~125	°C
Storage Temperature	T _s	-65~150	°C
Thermal Resistance Junction – Case (*)	R _{θJC}	150	°C/W
Power Dissipation	P _D	630	mW

The IC has a protection circuit against static electricity. Do not apply high static electricity or high voltage that exceeds the performance of the protection circuit to the IC.

BM0550HV

Universal High Brightness LED Driver

ELECTRICAL CHARACTERISTICS

($T_A=25^{\circ}\text{C}$, $V_{IN}=12\text{V}$, Unless otherwise specified)

Symbol	Parameter	Conditions	Min.	Typ.	Max.	Unit
Supply Voltage (VIN Pin)						
I_{SD}	Shut Down Mode Supply Current	DIM to Ground,		0.5	1	mA
V_{in}	DC Input Supply Voltage		10		600	V
UVLO (on)	Start Threshold Voltage	V_{DD} Rising	6.45	6.7	6.95	V
Δ UVLO	Under Voltage Lockout Hysteresis	V_{DD} Falling		500		mV
Internal Regulator (VDD Pin)						
V_{DD}	Internal Regulated Voltage	$V_{in}=10\text{V}\sim 600\text{V}$, $I_{DD}=0$, Gate Open	7.0	7.5	8.0	V
Δ V_{DD}	Load Regulation	$I_{DD}=0\sim 1\text{mA}$, $V_{DIM}=V_{DD}$, $R_{osc}=226\text{K}\Omega$, Gate=500pF			100	mV
V_{DD}	Maximum V_{DD} Voltage	Apply External Voltage			10	V
$I_{DD(ext)}$	Current Available for External Circuit	$V_{in}=15\sim 100\text{V}$			0.7	mA
Oscillator (Rosc Pin)						
F_{OSC}	Frequency	$R_{osc}=1\text{M}\Omega$	20	25	30	KHz
		$R_{osc}=226\text{K}\Omega$	80	100	120	KHz
Current Sensing (CS Pin)						
$V_{CS(TH)}$	Current Sense Pull-in Threshold Voltage	$T_A=-40^{\circ}\text{C}\sim 85^{\circ}\text{C}$	225	250	275	mV
T_{BLANK}	Current Sense Blanking Interval	$V_{CS}=0.55V_{LD}$, $V_{LD_i}=V_{DD}$	150	215	280	nS
T_{DELAY}	Delay to Output	$V_{LD}=0.15\text{V}$, $V_{CS}=0\sim 0.22\text{V}$ after T_{BLANK} , $V_{in}=12\text{V}$			300	nS
Gate Driver Output (GATE Pin)						
V_{OL}	Output Low Level	$I_o=-10\text{mA}$	0		0.3	V
V_{OH}	Output High Level	$I_o=10\text{mA}$	$V_{DD}-0.3$		V_{DD}	V
T_r	Rising Time	Load Cap=500pF, $V_{DD}=7.5\text{V}$	30		50	nS
T_f	Falling Time	Load Cap=500pF, $V_{DD}=7.5\text{V}$	30		50	nS
PWM Dimming (DIM Pin)						
$V_{EN(LO)}$	PWM Dimming Input Low Voltage	$V_{in}=10\text{V}\sim 600\text{V}$			0.8	V
$V_{EN(HI)}$	PWM Dimming Input High Voltage	$V_{in}=10\text{V}\sim 600\text{V}$	2			V
REN	PWM Dimming Pull Down Resistance	$V_{EN}=5\text{V}$	50	100	150	K Ω
Linear Dimming (Ld Pin)						
V_{LD}	Linear Dimming Voltage	$V_{in}=12\text{V}$, $T_A<85^{\circ}\text{C}$			250	mV

BM0550HV

Universal High Brightness LED Driver

SOP-8 PACKAGE OUTLINE

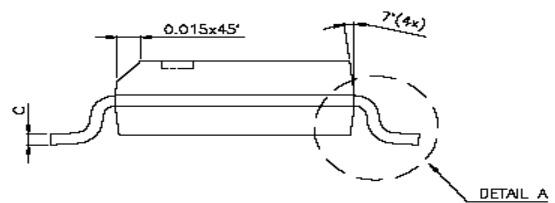
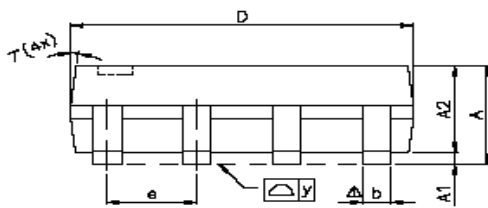
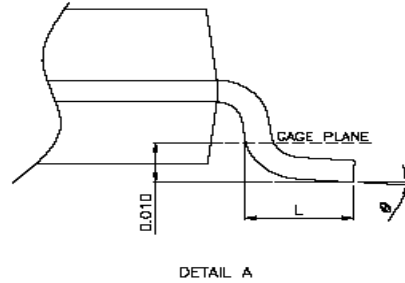
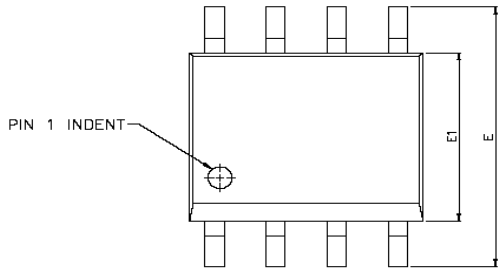

SYMBOLS	DIMENSIONS IN MILLIMETERS			DIMENSIONS IN INCHES		
	MIN	NOM	MAX	MIN	NOM	MAX
A	1.47	1.60	1.73	0.058	0.063	0.068
A1	0.10	—	0.25	0.004	—	0.010
A2	—	1.45	—	—	0.057	—
b	0.33	0.41	0.51	0.013	0.016	0.020
C	0.19	0.20	0.25	0.0075	0.008	0.0098
D	4.80	4.85	4.95	0.189	0.191	0.195
E	5.80	6.00	6.20	0.228	0.236	0.244
E1	3.80	3.90	4.00	0.150	0.154	0.157
e	—	1.27	—	—	0.050	—
L	0.38	0.71	1.27	0.015	0.028	0.050
Δ y	—	—	0.076	—	—	0.003
θ	0°	—	8°	0°	—	8°