

Ver 1.1

Radiation Hardened 16-Channel Current Positive Driver

Datasheet

Part Number: BM2712MQRH



北京微电子技术研究所

Beijing Microelectronics Technology Institute

Page of Revise Control

Version No.	Publish Time	Revised Chapter	Revise Introduction	Note
1.0	2017.12	-	-	
1.1	2018.3	-	Changed the template	

TABLE OF CONTENTS

1. Unique Features	1
2. General Description	1
3. Pin Description	1
4. Function Description	4
4.1 Function Block Diagram.....	4
4.2 Truth Table	4
4.3 Logical Relationships.....	5
5. Electrical Characteristic.....	5
5.1 Absolute Maximum Rating	5
5.2 Recommended Operating Conditions	5
5.3 Electrical Specifications.....	6
5.4 ESD Caution	7
6. Typical Application.....	7
6.1 Typical Application Circuit.....	7
6.2 Power Dissipation Expression	8
7. Package Outline dimensions.....	9

1. Unique Features

- 1) 16 Channels
- 2) Supply Voltage (V_{DD})12V~33V
- 3) Higher than 200mA driver ability for each channel
- 4) Dual enable control signal
- 5) T_A-55°C~125°C
- 6) Package.....CQFP64
- 7) Total Ionizing Dose ≥ 100 krad (Si)
- 8) The Single Event Latch-up Immunity

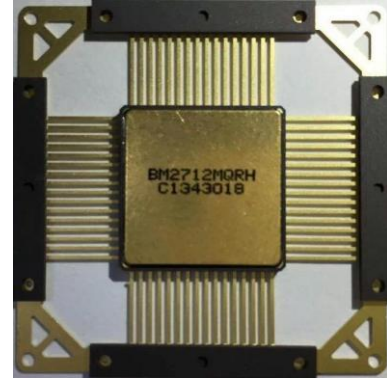

2. General Description

The device implements 16-channel switch instruction driver. Each channel can be controlled by two independent signals. When these two signals are simultaneously active (high level), the instruction signal will be presented at the output. The power loop can be switched on or off by the instruction signal. Each channel's pre-driver and post-switch circuits are designed by redundant structure that can improve circuit's reliability and robustness. There is an excellent isolation between each channel. If one channel is abnormal, the other channels won't be affected and can output exactly.

3. Pin Description

The pins description of BM2712MQRH is shown in figure 1, Table 1.

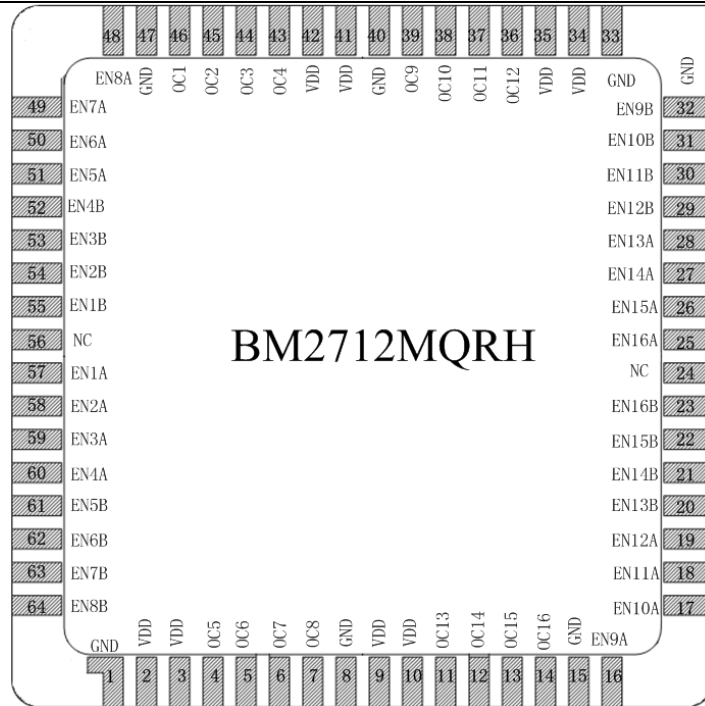

Figure1. BM2712MQRH Pin Configuration (Top View)

Table1. BM2712MQRH Pin Configuration

Pin	Description	Symbol	Pin	Description	Symbol
1	Ground	GND	33	Ground	GND
2	Power Supply	VDD	34	Power Supply	VDD
3	Power Supply	VDD	35	Power Supply	VDD
4	5 th Output	OC5	36	12 th Output	OC12
5	6 th Output	OC6	37	11 th Output	OC11
6	7 th Output	OC7	38	10 th Output	OC10
7	8 th Output	OC8	39	9 th Output	OC9
8	Ground	GND	40	Ground	GND
9	Power Supply	VDD	41	Power Supply	VDD
10	Power Supply	VDD	42	Power Supply	VDD
11	13 th Output	OC13	43	4 th Output	OC4
12	14 th Output	OC14	44	3 th Output	OC3
13	15 th Output	OC15	45	2 nd Output	OC2
14	16 th Output	OC16	46	1 st Output	OC1
15	Ground	GND	47	Ground	GND

16	9 th A Input	EN9A	48	8 th A Input	EN8A
17	10 th A Input	EN10A	49	7 th A Input	EN7A
18	11 th A Input	EN11A	50	6 th A Input	EN6A
19	12 th A Input	EN12A	51	5 th A Input	EN5A
20	13 th B Input	EN13B	52	4 th B Input	EN4B
21	14 th B Input	EN14B	53	3 th B Input	EN3B
22	15 th B Input	EN15B	54	2 th B Input	EN2B
23	16 th B Input	EN16B	55	1 st B Input	EN1B
24	NC	NC	56	NC	NC
25	16 th A Input	EN16A	57	1 th A Input	EN1A
26	15 th A Input	EN15A	58	2 nd A Input	EN2A
27	14 th A Input	EN14A	59	3 th A Input	EN3A
28	13 th A Input	EN13A	60	4 th A Input	EN4A
29	12 th B Input	EN12B	61	5 th B Input	EN5B
30	11 th B Input	EN11B	62	6 th B Input	EN6B
31	10 th B Input	EN10B	63	7 th B Input	EN7B
32	9 th B Input	EN9B	64	8 th B Input	EN8B

4. Function Description

4.1 Function Block Diagram

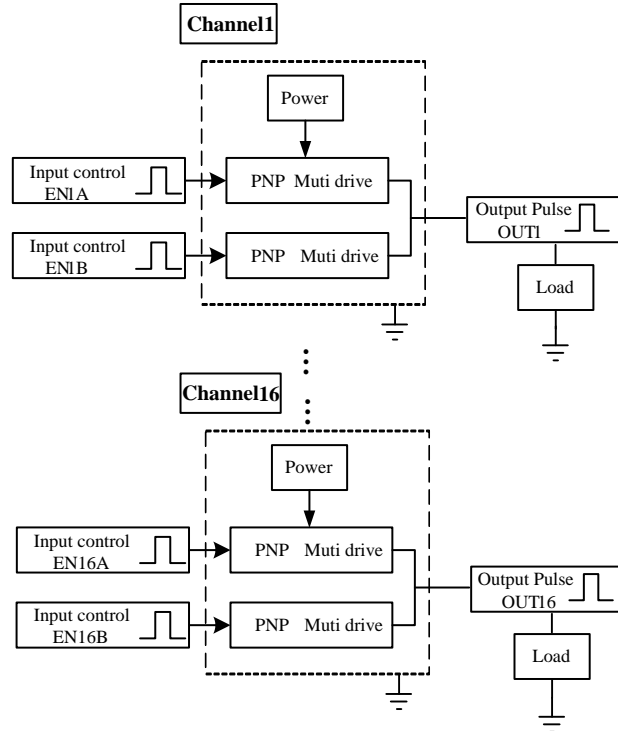

Figure2. Function Block Diagram

4.2 Truth Table

Table2. Truth Table for Single Channel

Input		Output
ENiA	ENiB	OCi
0	0	high-Z
0	1	high-Z
1	0	high-Z
1	1	1

4.3 Logical Relationships

Table 3. Logical Relationships

Input ENiA&ENiB	Output															
	1	2	3	4	5	6	7	8	9	10	11	12	13	14	15	16
EN1A&EN1B	1	1	×	×	×	×	×	×	×	×	×	×	×	×	×	×
EN2A&EN2B	1	×	1	×	×	×	×	×	×	×	×	×	×	×	×	×
EN3A&EN3B	1	×	×	1	×	×	×	×	×	×	×	×	×	×	×	×
EN4A&EN4B	1	×	×	×	1	×	×	×	×	×	×	×	×	×	×	×
EN5A&EN5B	1	×	×	×	×	1	×	×	×	×	×	×	×	×	×	×
EN6A&EN6B	1	×	×	×	×	×	1	×	×	×	×	×	×	×	×	×
EN7A&EN7B	1	×	×	×	×	×	×	1	×	×	×	×	×	×	×	×
EN8A&EN8B	1	×	×	×	×	×	×	×	1	×	×	×	×	×	×	×
EN9A&EN9B	1	×	×	×	×	×	×	×	×	1	×	×	×	×	×	×
EN10A&EN10B	1	×	×	×	×	×	×	×	×	×	1	×	×	×	×	×
EN11A&EN11B	1	×	×	×	×	×	×	×	×	×	×	1	×	×	×	×
EN12A&EN12B	1	×	×	×	×	×	×	×	×	×	×	×	1	×	×	×
EN13A&EN13B	1	×	×	×	×	×	×	×	×	×	×	×	×	1	×	×
EN14A&EN14B	1	×	×	×	×	×	×	×	×	×	×	×	×	×	1	×
EN15A&EN15B	1	×	×	×	×	×	×	×	×	×	×	×	×	×	×	1
EN16A&EN16B	1	×	×	×	×	×	×	×	×	×	×	×	×	×	×	1

¹ × indicates that i-channel's output is link to i-channel's input only.
² In any time, there's only one channel can work (when the output drive current is 200mA)

5. Electrical Characteristic

5.1 Absolute Maximum Rating

Parameter	Symbol	Data		Unit
		Min	Max	
Supply Voltage	V_{DD}	-0.3	50	V
Output Current	I_O	0	360	mA
Power Dissipation	P_T	0	2.5	W
Input Signal Range	V_{EN}	0	12	V
Storage Temperature Range	T_{stg}	-65	+150	°C
Lead Temperature (10s)	T_h	—	300	°C
Junction Temperature	T_j	—	150	°C

5.2 Recommended Operating Conditions

Parameter	Symbol	Data		Unit
		Min	Max	
Supply Voltage	V_{DD}	12	33	V
Output Current	I_O	0	200	mA
Input Signal Range	V_{EN}	0	5.5	V
Temperature Range	T_A	-55	125	°C

5.3 Electrical Specifications

$V_{DD}=28V$, $-55^{\circ}C \leq T_A \leq 125^{\circ}C$, unless otherwise noted

Table 4. Electronic Specifications

Parameter	Symbol	Condition	Data		Unit
		$-55^{\circ}C \leq T_A \leq 125^{\circ}C$ $V_{DD}=28V$, $GND=0V$, unless otherwise noted	Min	Max	
Output leakage current	I_{OD}	$V_{ENXA}=V_{ENXB}=0.6V$ ($x=1 \dots 16$), $R_L=120\Omega$, Measured Output $ I_{ODX} $ (Measured 16 channels individually)	--	40	uA
		$V_{ENXA}=0.6V$, $V_{ENXB}=3.0V$ ($x=1 \dots 16$), $R_L=120\Omega$, Measured Output $ I_{ODX} $ (Measured 16 channels individually)	--	40	
		$V_{ENXA}=3.0V$, $V_{ENXB}=0.6V$ ($x=1 \dots 16$), $R_L=120\Omega$, Measured Output $ I_{ODX} $ (Measured 16 channels individually)	--	40	
Output Saturation Voltage Drop	V_{CESAT}	$V_{ENXA}=3.0V$, $V_{ENXB}=3.0V$ ($x=1 \dots 16$), $I_{OH}=-200mA$, Measured Output V_{OUTX} , $V_{CESAT}=V_{DD} - V_{OUTX}$ (Measured 16 channels individually)	--	3	V
High Level Output Voltage	V_{OH}	$V_{ENXA}=3.0V$, $V_{ENXB}=3.0V$ ($x=1 \dots 16$), $I_{OH}=-200mA$, Measured Output V_{OUTX} (Measured 16 channels individually)	25	--	V
Output Current	I_O	$V_{ENXA}=3.0V$, $V_{ENXB}=3.0V$ ($x=1 \dots 16$), $V_{CESAT}=3.0V$, Measured Output $ I_{OX} $ (Measured 16 channels individually)	200	--	mA
High Level Input Voltage	V_{IH}	$I_{OH}=-200mA$, $V_{CESAT}=3.0V$	3.0	--	V
Low Level Input Voltage	V_{IL}		--	0.6	V
High Level Input Current	I_{IH}	$V_{ENXA}=3.0V$, $V_{ENXB}=3.0V$ ($x=1 \dots 16$), (other channels with no x , $V_{ENXA}=V_{ENXB}=0.6V$), $I_{OH}=-200mA$, Measured Input I_{IHx} (Measured 16 channels individually)	--	0.8	mA
Static Current	I_D	$V_{ENXA}=0.6V$, $V_{ENXB}=0.6V$ ($x=1 \dots 16$) (other channels with no x , $V_{ENYA}=V_{ENYB}=0.6V$), Measured Power	--	1	mA

Parameter	Symbol	Condition -55°C ≤ T _A ≤ 125°C V _{DD} =28V, GND=0V, unless otherwise noted	Data		Unit
			Min	Max	
Operating Current	I _{VDD}	V _{ENXA} =3.0V, V _{ENXB} =3.0V (x=1.....16) (other channels with no x, V _{ENXA} =V _{ENXB} =0.6V), I _{OH} =-200mA, Measured Power I, I _{VDD} =I-200mA (Measured 16 channels individually)	--	50	mA
Function Test		V _{ENXA} =3.0V, V _{ENXB} =3.0V (x=1.....16), I _{OH} =-200mA, Measured Output V _{OUTX} (Measured 16 channels individually)	25	--	V
Turn-on Time ^a	t _{ON}	V _{DD} =28V, f=1kHz, R _L =120Ω, measured as the figure3	--	10	us
Turn-off Time ^a	t _{OFF}	V _{DD} =28V, f=1kHz, R _L =120Ω, measured as the figure3	--	70	us
Rise Time ^a	t _{UP}	V _{DD} =28V, f=1kHz, R _L =120Ω, measured as the figure4	--	8	us
Fall Time ^a	t _{DOWN}	V _{DD} =28V, f=1kHz, R _L =120Ω, measured as the figure4	--	65	us

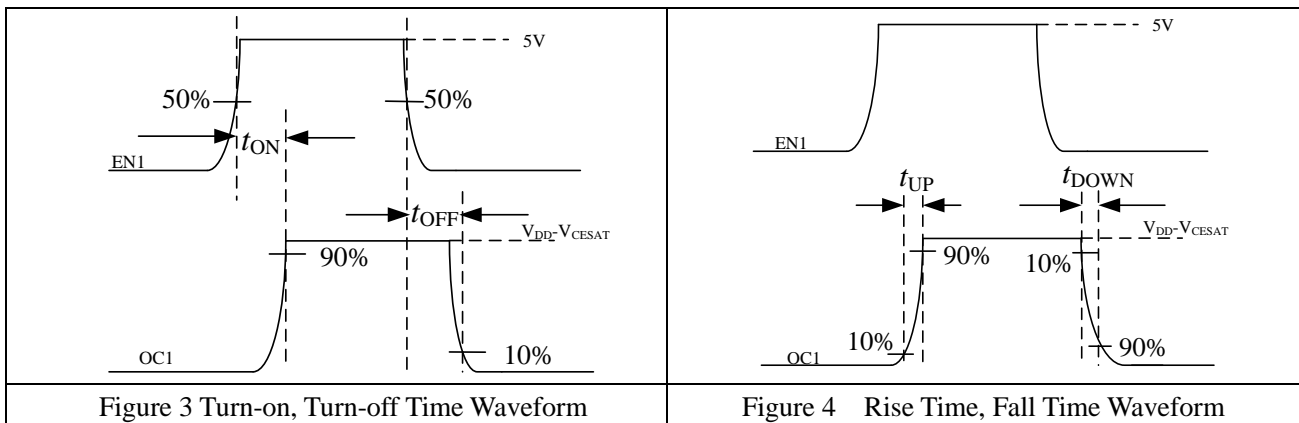

5.4 ESD Caution

ESD (electrostatic discharge) sensitive device. Electrostatic charges as high as 2000 V readily accumulated on the human body fits the 2nd Level of 3015 in GJB548B-2005.

6. Typical Application

6.1 Typical Application Circuit

The GND pin should be connected to the reference ground of control signal, or the common ground of control signal ground and instruction signal ground. It can be

selected by customer.

The figure 5 shows that the GND pin is individually connected to the reference ground of control signal, and the ground of instruction signal. V_{DD} is the power of instruct signal. GND is the reference ground of control signal. R_i is the load of instruct signal which is connected to OC_i and the ground.

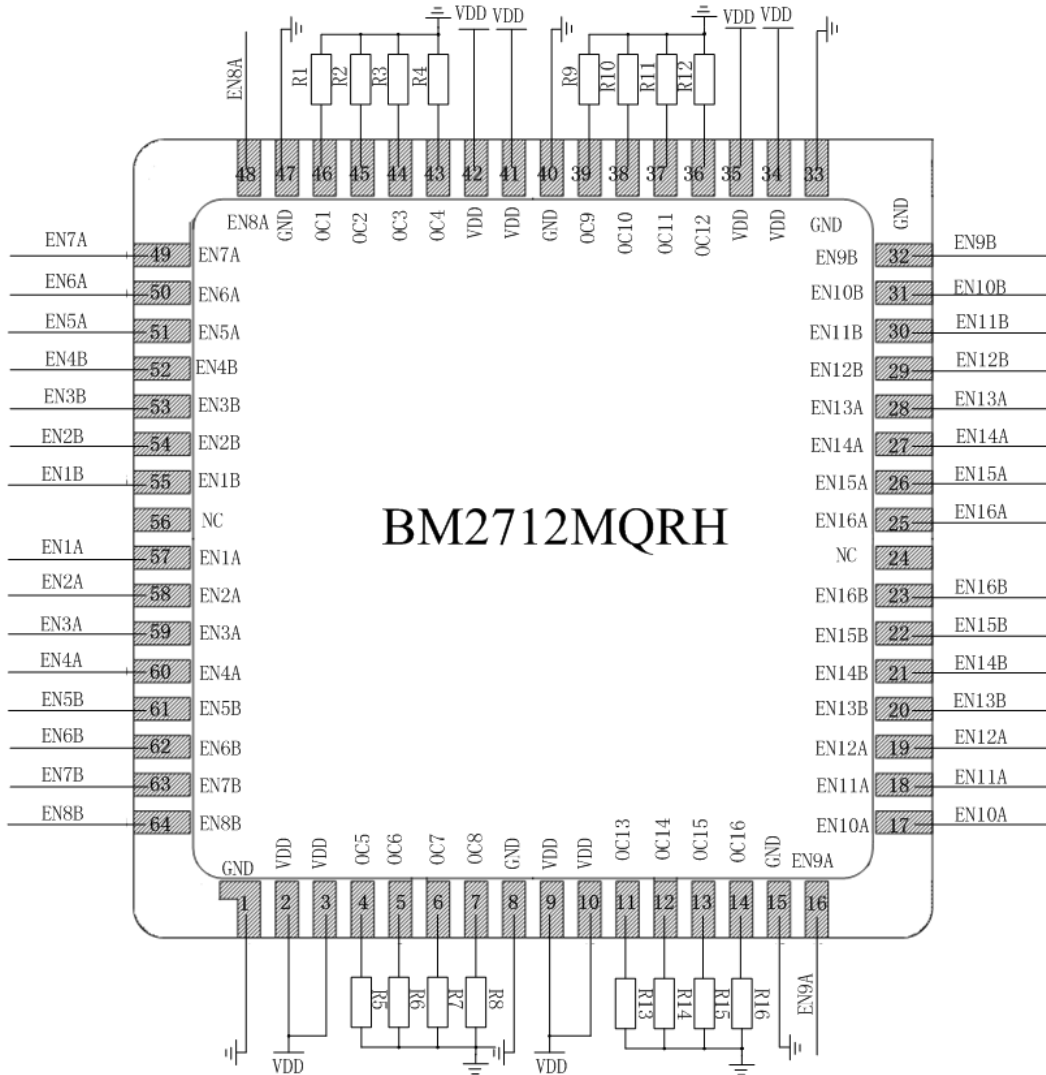

Figure 5. BM2712MQRH Typical Application Circuit

6.2 Power Dissipation Expression

The number of active channels is limited by the device's maximum power consumption.

The device's power consumption is composed by three parts: the power consumption of input drives, power supplies and output drives. And the device's power consumption expression can be written as below:

$$P = I_{EN} \times V_{EN} + I_{VDD} \times V_{DD} + I_O \times V_{CESAT}$$

The maximum power consumption of the device is 2.5W, and each channel's power consumption could be derived by the parameters of the electrical characteristics table as following:

$$P_1=0.0008 \times 5.5 \times 2+0.05 \times 33+0.2 \times 3=2.2588W$$

So the number of active channels is only one because the whole power consumption of the device is all channels' power summation.

7. Package Outline dimensions

7.1 BM2712MQRH's packaging is CQFP64 which is shown as follows.

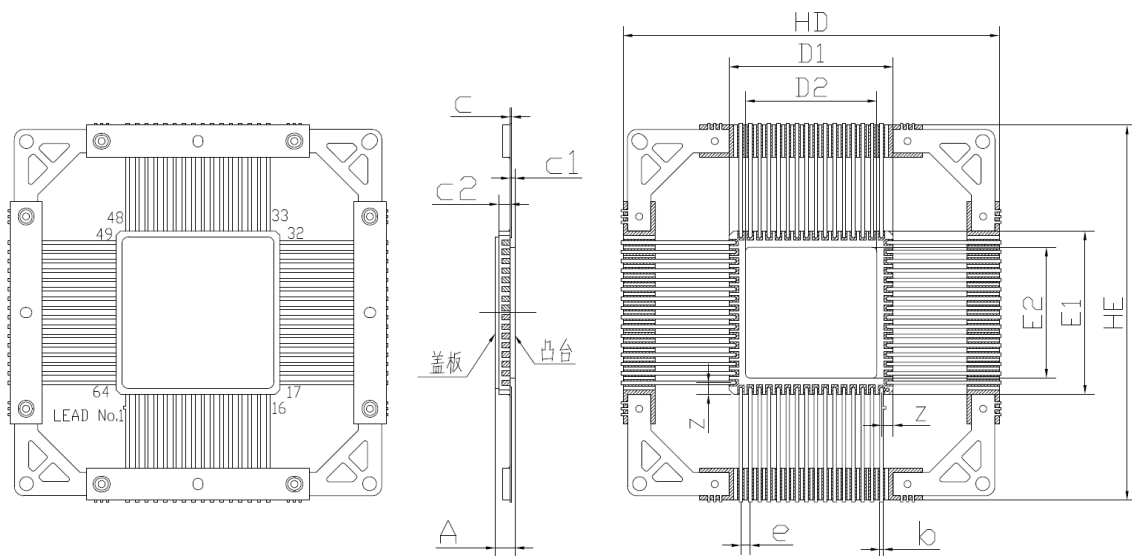

Figure 6. BM2712MQRH's Package (CQFP64)

Table 5. Dimensions

Symbol	Data(Unit: mm)		
	Min	typical	Max
A	1.85	—	2.50
b	0.3	—	0.46
c	0.09	—	0.21
c1	0.35	—	0.57
c2	1.05	—	1.93
HD/HE	39.90	—	41.60
D1/E1	17.40	—	18.15
D2/E2	13.95	—	14.55
e	—	1.016	—
Z	1.09	—	1.45

7.2 The Outline dimensions of CQFP64 which is cut for use.

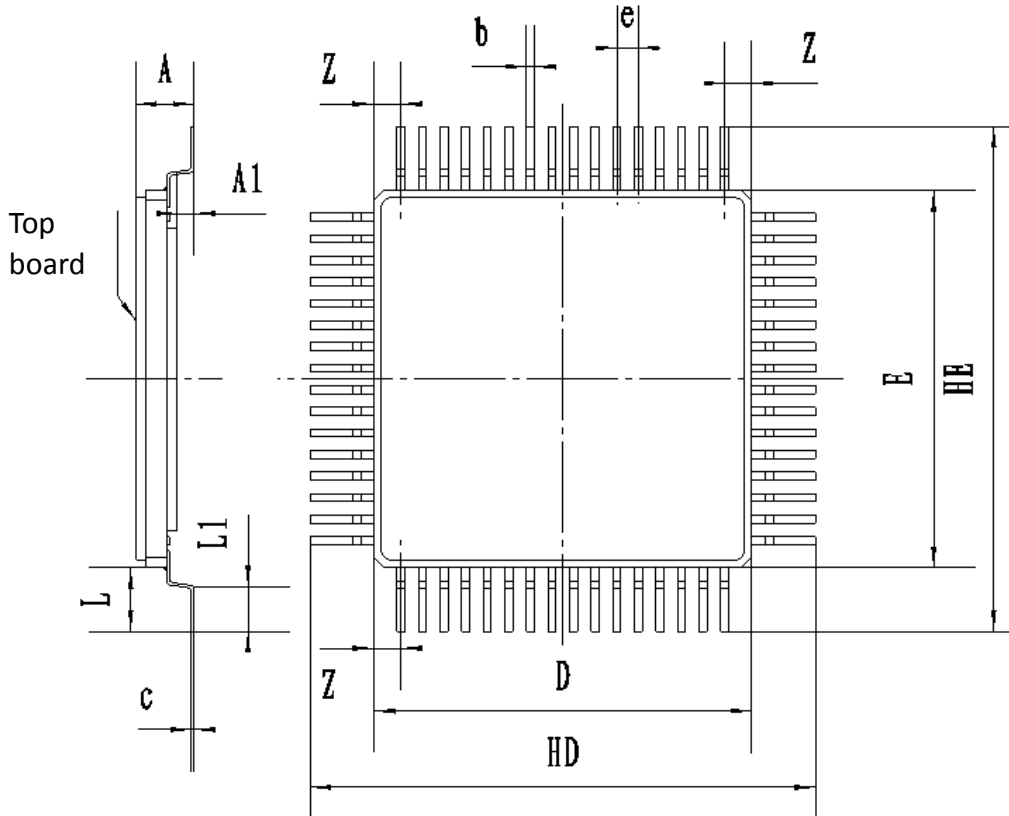

Figure 7. Cutting Forming Diagram

Table 6. Cutting Forming Dimensions

Symbol	Data (Unit: mm)		
	Min	typical	Max
A	2.3		3.2
A1	0.5	0.75	1.01
b		0.381	
c		0.152	
e		1.016	
Z		1.27	
D/E		17.78	
HD/HE	21.58	22.78	23.98
L1	1.25	1.5	1.75
L	2.0	2.5	3.0

Service & Supply

Address: No.2.Siyingmen N.Rd.Donggaodi, Fengtai District, Beijing, PRC

Department: Department of international cooperation

Telephone: 010-67968115-8334

Fax: 010-68757706

Zip code: 100076