

ADJUSTABLE PRECISION SHUNT REGULATORS**BM431****General Description**

The BM431 series ICs are three-terminal adjustable shunt regulators with guaranteed thermal stability over a full operation range. These ICs feature sharp turn-on characteristics, low temperature coefficient and low output impedance, which make them ideal substitutes for Zener diodes in applications such as switching power supply, charger and other adjustable regulators.

The BM431 series ICs is pb-free already for all the package. The output voltage of all types can be set to any value between V_{REF} (2.5V) and the corresponding maximum cathode voltage.

The BM431 precision reference is offered in two band-gap tolerance: 0.4% and 0.8%.

These ICs are available in 2 Packages: TO-92, SOT-23-3

Features

- Programmable Precise Output Voltage from 2.5V to 36V
- Very Accurate Reference Voltage: 0.15% Typical
- High Stability under Capacitive Load
- Low Temperature Deviation: 4.5mV Typical
- Low Equivalent Full-range Temperature Coefficient with 20PPM/°C Typical
- Low Dynamic Output Resistance: 0.2Ω Typical
- Sink Current Capacity from 1mA to 100 mA
- Low Output Noise
- Wide Operating Range of -40 to 125°C

Applications

- Charger
- Voltage Adapter
- Switching Power Supply
- Graphic Card
- Precision Voltage Reference

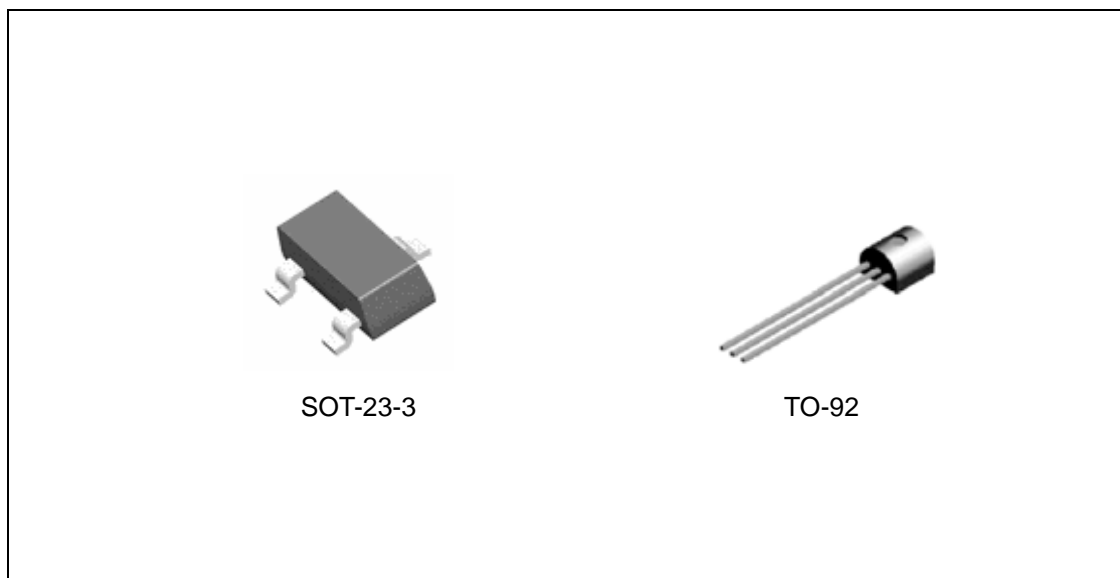

Figure 1. Package Types of BM431

ADJUSTABLE PRECISION SHUNT REGULATORS**BM431****Pin Configuration**

Figure 2. Pin Configuration of BM431 (Top View)

PART NO. BM431SA, A=0.4%, S=SOT23-3 package
 BM431SB, B=0.8%, S=SOT23-3 package
 BM431TA, A=0.4%, T=TO92 package
 BM431TB, B=0.8%, T=TO92 package

Functional Block Diagram

Figure 3. Functional Block Diagram of BM431

ADJUSTABLE PRECISION SHUNT REGULATORS**BM431****Absolute Maximum Ratings (Note 1)**

Parameter	Symbol	Value	Unit
Cathode Voltage	V_{KA}	BM431 : 40	V
Cathode Current Range (Continuous)	I_{KA}	-100 to 150	mA
Reference Input Current Range	I_{REF}	10	mA
Power Dissipation	P_D	M, Z, R Package: 770	mW
		N, K Package: 370	
Junction Temperature	T_J	160	°C
Storage Temperature Range	T_{STG}	-65 to 150	°C
Package Thermal Impedance	θ_{JA}	M Package: 150	°C/W
		N Package: 330	
		Z Package: 150	
		R Package: 50	
		K Package: 250	
ESD (Human Body Model)		2000	V

Note 1: Stresses greater than those listed under "Absolute Maximum Ratings" may cause permanent damage to the device. These are stress ratings only, and functional operation of the device at these or any other conditions beyond those indicated under "Recommended Operating Conditions" is not implied. Exposure to "Absolute Maximum Ratings" for extended periods may affect device reliability.

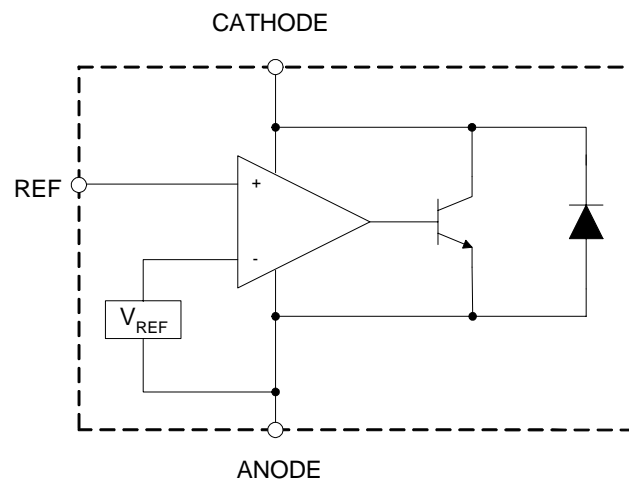
Recommended Operating Conditions

Parameter	Symbol	Min	Max	Unit
Cathode Voltage	V_{KA}	V_{REF}	BM431 : 36	V
Cathode Current	I_{KA}	1.0	100	mA
Operating Ambient Temperature Range		-40	125	°C

ADJUSTABLE PRECISION SHUNT REGULATORS**BM431****Electrical Characteristics for BM431**Operating Conditions: $T_A=25^{\circ}\text{C}$ unless otherwise specified.

Parameter	Test Circuit	Symbol	Conditions	BM431			Unit	
				Min	Typ	Max		
Reference Voltage	0.4%	4	V_{REF}	$V_{\text{KA}}=V_{\text{REF}}, I_{\text{KA}}=10\text{mA}$	2.490	2.500	2.510	V
	0.8%				2.480	2.500	2.520	
Deviation of Reference Voltage Over-Temperature	4	ΔV_{REF}	$V_{\text{KA}}=V_{\text{REF}}, I_{\text{KA}}=10\text{mA}$	0 to 70°C	4.5	8	mV	
				-40 to 85°C	4.5	10		
Ratio of Change in Reference Voltage to the Change in Cathode Voltage	5	$\frac{\Delta V_{\text{REF}}}{\Delta V_{\text{KA}}}$	$I_{\text{KA}}=10\text{mA}$	$\Delta V_{\text{KA}}=10\text{V to }V_{\text{REF}}$	-1.0	-2.7	mV/V	
				$\Delta V_{\text{KA}}=36\text{V to }10\text{V}$	-0.5	-2.0		
Reference Current	5	I_{REF}	$I_{\text{KA}}=10\text{mA}, R1=10\text{K}\Omega, R2=\infty$		0.7	4	μA	
Deviation of Reference Current Over Full Temperature Range	5	ΔI_{REF}	$I_{\text{KA}}=10\text{mA}, R1=10\text{K}\Omega, R2=\infty, T_A=-40\text{ to }85^{\circ}\text{C}$		0.4	1.2	μA	
Minimum Cathode Current for Regulation	4	$I_{\text{KA}}(\text{Min})$	$V_{\text{KA}}=V_{\text{REF}}$		0.4	1.0	mA	
Off-State Cathode Current	6	$I_{\text{KA}}(\text{Off})$	$V_{\text{KA}}=36\text{V}, V_{\text{REF}}=0$		0.05	1.0	μA	
Dynamic Impedance	4	Z_{KA}	$V_{\text{KA}}=V_{\text{REF}}, I_{\text{KA}}=1\text{ to }100\text{mA}, f \leq 1.0\text{KHz}$		0.15	0.5	Ω	

Electrical Characteristics (Continued)

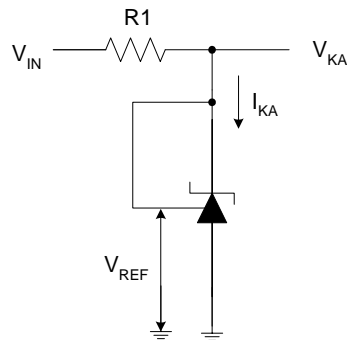
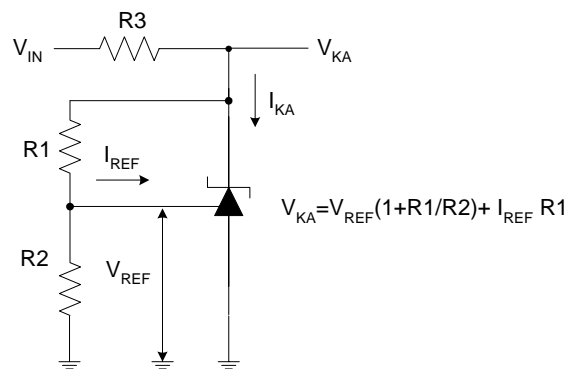
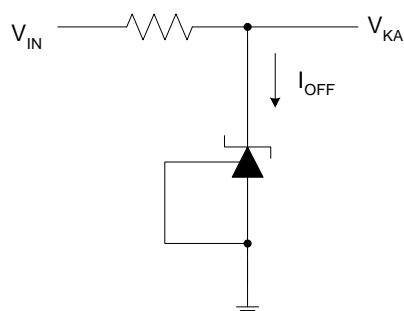
Figure 4. Test Circuit 4 for $V_{KA}=V_{ref}$ Figure 5. Test Circuit 5 for $V_{KA}>V_{ref}$ Figure 6. Test Circuit 6 for I_{OFF}

Typical Performance Characteristics

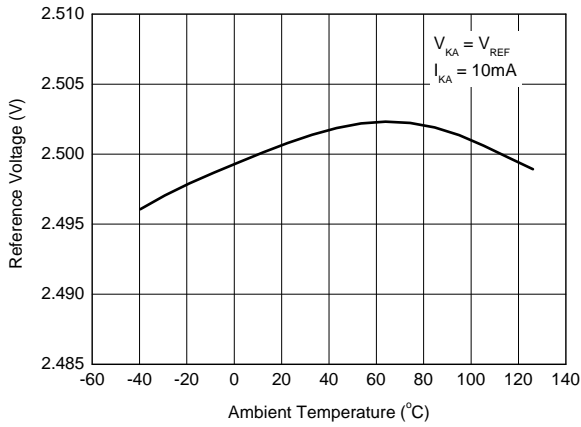

Figure 7. Reference Voltage vs. Ambient Temperature

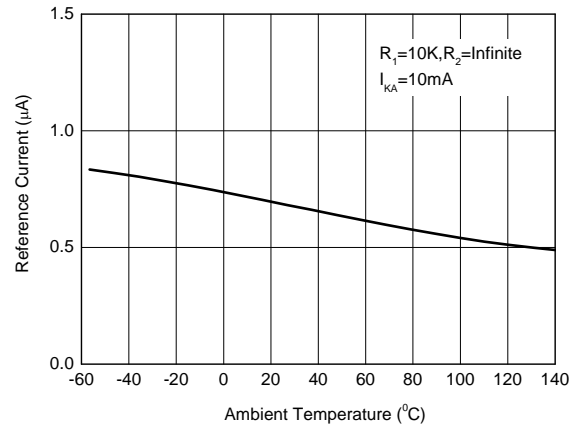

Figure 8. Reference Current vs. Ambient Temperature

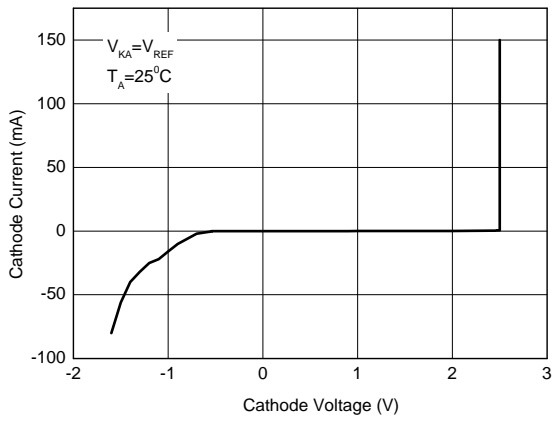

Figure 9. Cathode Current vs. Cathode Voltage

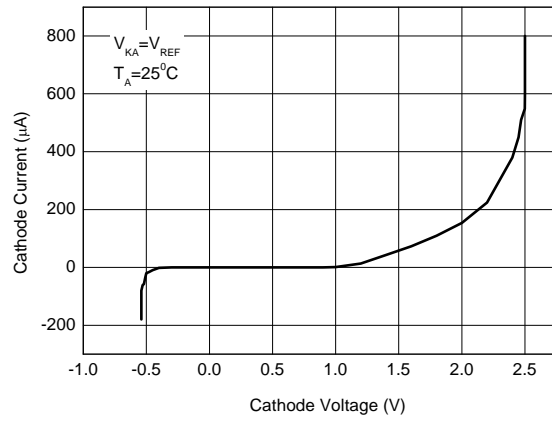

Figure 10. Cathode Current vs. Cathode Voltage

ADJUSTABLE PRECISION SHUNT REGULATORS

BM431

Typical Application

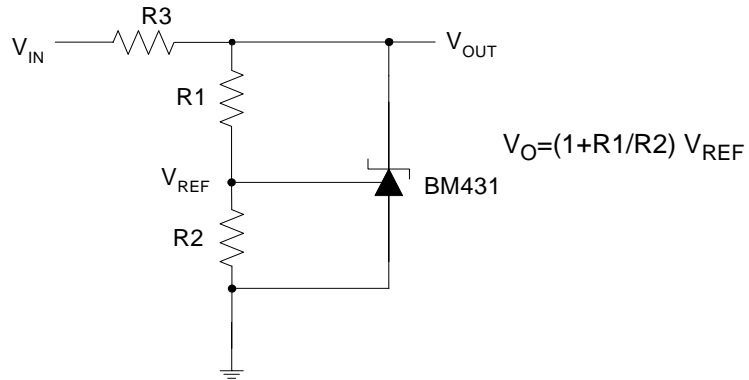

Figure 17. Shunt Regulator

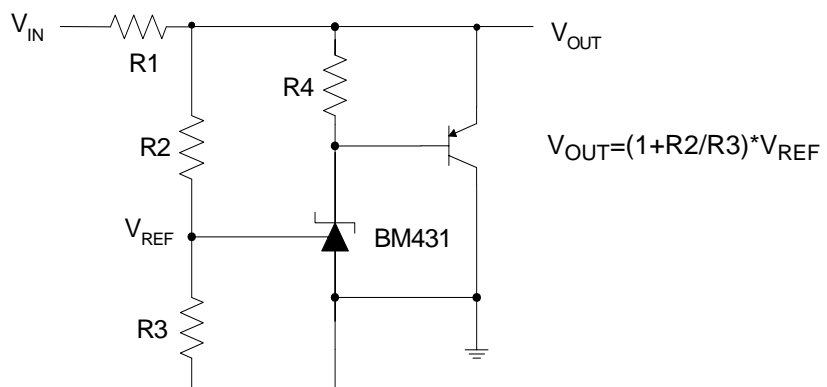

Figure 18. High Current Shunt Regulator

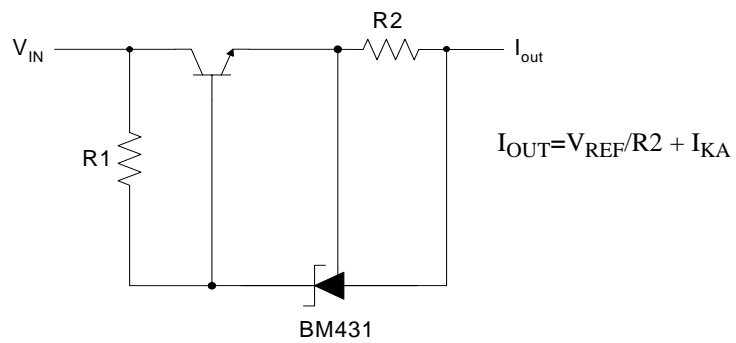

Figure 19. Current Source or Current Limit

ADJUSTABLE PRECISION SHUNT REGULATORS

BM431

Typical Application (Continued)

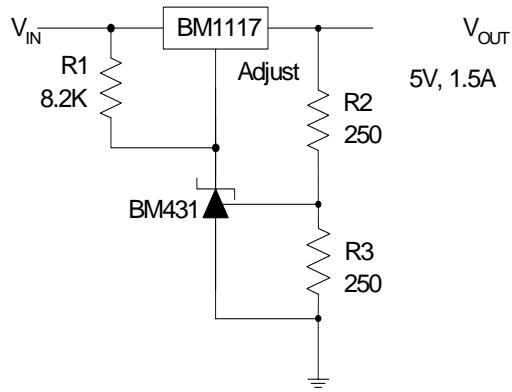

Figure20. Precision 5V 1.5A Regulator

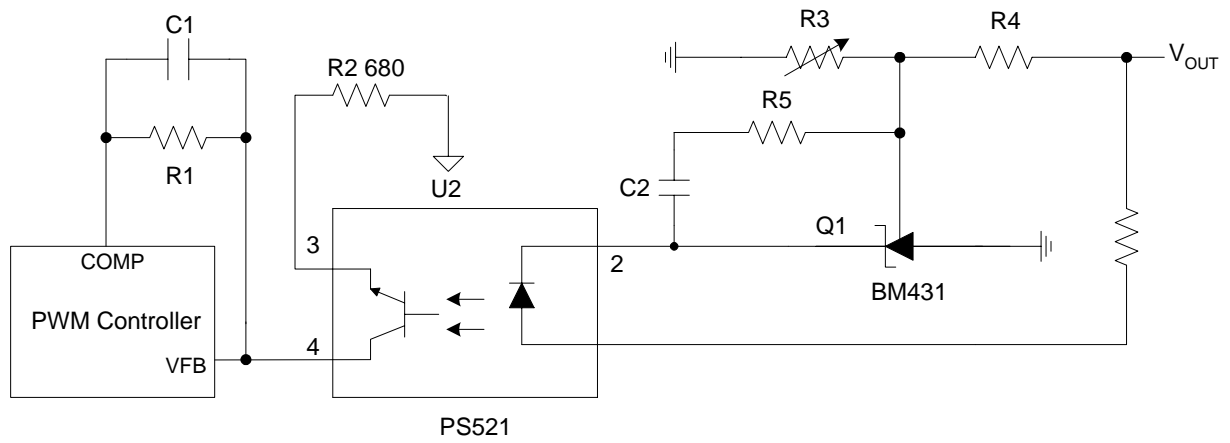

Figure 21. PWM Converter with Reference

ADJUSTABLE PRECISION SHUNT REGULATORS

BM431

Mechanical Dimensions

TO-92

Unit: mm (inch)

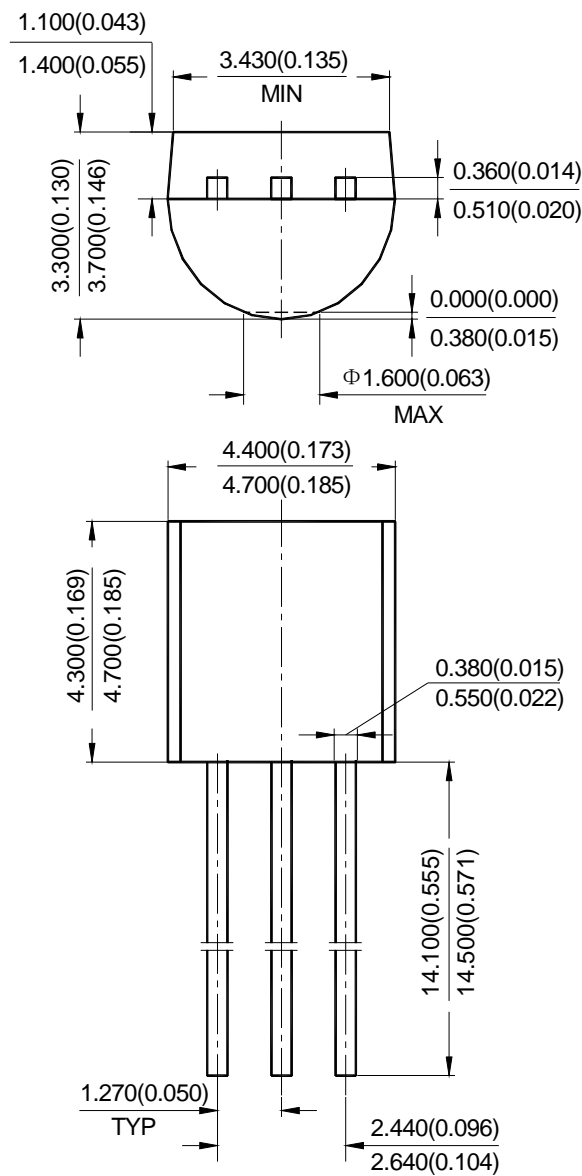

ADJUSTABLE PRECISION SHUNT REGULATORS

BM431

Mechanical Dimensions (Continued)

SOT-23-3

Unit: mm(inch)

