

General Description

The BM432(BM431L) are low voltage three-terminal adjustable regulators with guaranteed thermal stability over a full operation range. These ICs feature sharp turn-on characteristics, low temperature coefficient and low output impedance, which make them ideal substitutes for Zener diodes in applications such as switching power supply, charger, motherboard and other adjustable regulators.

The output voltage can be set to any value between 1.24V and 18V with two external resistors.

The BM432(BM431L) reference is offered in two bandgap tolerance: 0.5% and 1%.

The 4 main packages have low thermal impedance which allows operation over a wide range of -40°C to 125°C.

Features

- Wide programmable precise output voltage from 1.24V to 18V
- High stability under capacitive load
- Low temperature deviation: 3mV typical
- Low equivalent full-range temperature coefficient: 20PPM/°C typical
- Low dynamic output resistance: 0.05Ω typical
- High sink current capacity from 55μA to 100 mA
- Low output noise
- Available in 4 packages: TO-92, SOT-23-3, SOT-23-5, SOT-89

Applications

- Graphic Card
- PC Motherboard
- Voltage Adapter
- Switching Power Supply
- Charger

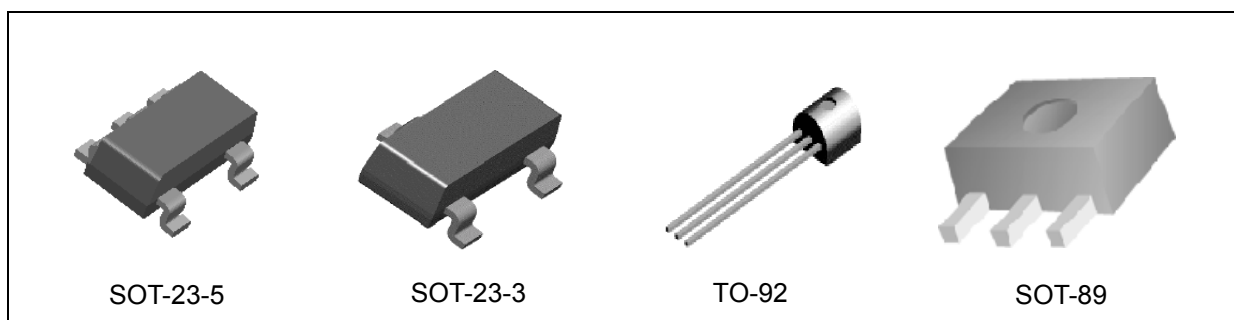

Figure 1. Package Types of BM432(BM431L)

LOW VOLTAGE (1.24V) ADJUSTABLE PRECISION SHUNT REGULATOR **BM432(BM431L)**

)Pin Configuration

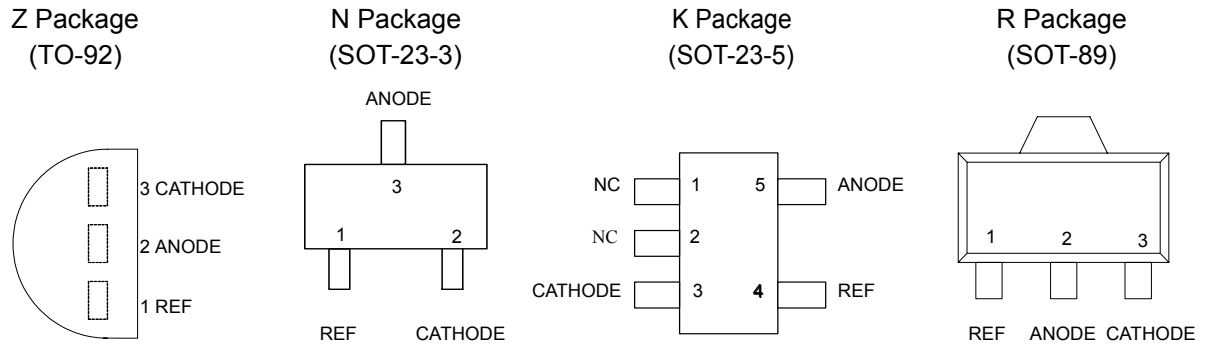

Figure 2. Pin Configuration of BM432 (BM431L)

Functional Block Diagram

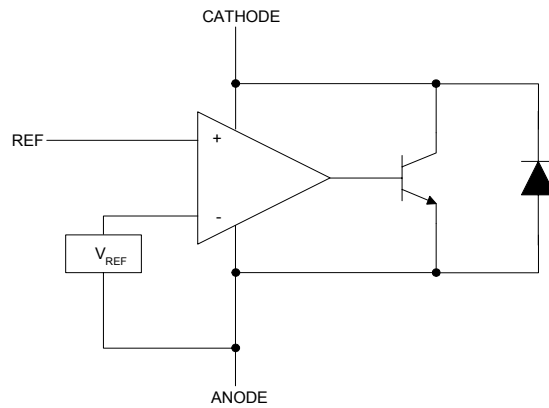

Figure 3. Functional Block Diagram of BM432(BM431L)

Ordering Information

Package	Temperature Range	Voltage Tolerance	Part Number		Packing Type
TO-92	-40°C ~ 125°C	0.5%	BM431LAZ		Bulk Ammo
		1%	BM431LBZ		
SOT-23-3		0.5%	BM431LAN		Reel
		1%	BM431LBN		
SOT-23-5		0.5%	BM431LAK		Reel
		1%	BM431LBK		
SOT - 89		0.5%	BM431LAR		Reel
		1%	BM431LBR		

Absolute Maximum Ratings (Note 1)

Parameter	Symbol	Value		Unit
Cathode Voltage	V_{KA}	20		V
Cathode Current Range (Continuous)	I_{KA}	-100 ~ +100		mA
Reference Input Current Range	I_{REF}	10		mA
Power Dissipation	P_D	Z,R Package	770	mW
		N,K Package	370	
Storage Temperature Range	T_{STG}	-65~+150		°C
Package Thermal Impedance	Q_{JA}	TO-92	130	°C/W
		SOT-23-3	330	
		SOT-23-5	250	
		SOT-89	100	

Note 1: Stresses greater than those listed under "Absolute Maximum Ratings" may cause permanent damage to the device. These are stress ratings only, and functional operation of the device at these or any other conditions beyond those indicated under "Recommended Operating Conditions" is not implied. Exposure to "Absolute Maximum Ratings" for extended periods may affect device reliability.

Recommended Operating Conditions

Parameter	Symbol	Min	Max	Unit
Cathode Voltage	V_{KA}	V_{REF}	18	V
Cathode Current	I_{KA}	0.1	100	mA
Operating Ambient Temperature Range		-40	125	°C

Electrical Characteristics

(Typical and limits apply for $T_j=25^\circ\text{C}$ unless otherwise noted.)

Parameter	Test Circuit	Symbol	Conditions	Min	Typ	Max	Unit
Reference Voltage	0.5%	V_{REF}	$V_{KA}=V_{REF}, I_{KA}=10\text{mA}$	1.234	1.240	1.246	V
	1%			1.228	1.240	1.252	
Deviation of Reference Voltage Over-Temperature	4	ΔV_{REF}	$V_{KA}=V_{REF}, I_{KA}=10\text{mA}$	$0^\circ\text{C} \sim 70^\circ\text{C}$	2	10	mV
				$-40^\circ\text{C} \sim 85^\circ\text{C}$	3	10	
Ratio of Change in V_{REF} to the Change in Cathode Voltage	5	$\frac{\Delta V_{REF}}{\Delta V_{KA}}$	$I_{KA}=10\text{mA}, \Delta Vz: V_{REF}$ to 16V		-0.5	-1.5	mV/V
Reference Input Current	5	I_{REF}	$I_{KA}=10\text{mA}, R1=10\text{K}\Omega, R2=\infty$		0.15	0.4	μA
Deviation of Reference Current Over Full Temperature Range	5	ΔI_{REF}	$I_{KA}=10\text{mA}, R1=10\text{K}\Omega, R2=\infty, T_A=-40$ to 85°C		0.1	0.4	μA
Minimum Cathode Current for Regulation	4	I_{KA} (MIN)	$V_{KA}=V_{REF}$		55	80	μA
Off-State Cathode Current	6	I_{KA} (OFF)	$V_{REF}=0, V_{KA}=18\text{V}$		0.04	0.10	μA
			$V_{KA}=6, V_{REF}=0$		0.01	0.05	
Dynamic Impedance	4	Z_{KA}	$V_{KA}=V_{REF}, I_{KA}=1$ to 100mA $f \leq 1.0\text{kHz}$		0.05	0.15	Ω

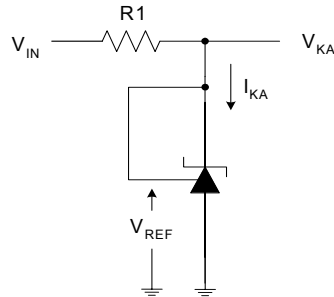

Figure 4. Test Circuit 4 for $V_{KA}=V_{REF}$

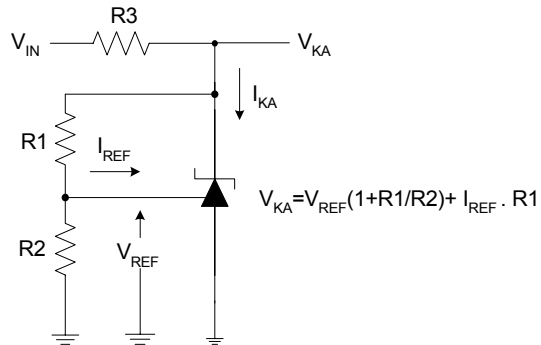

Figure 5. Test Circuit 5 for $V_{KA} > V_{REF}$

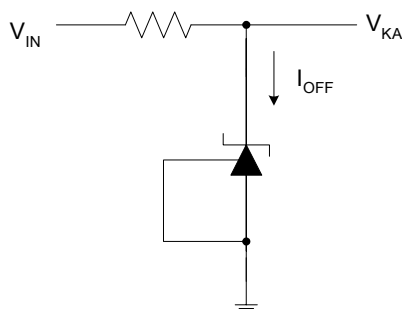

Figure 6. Test Circuit 6 for I_{OFF}

LOW VOLTAGE (1.24V) ADJUSTABLE PRECISION SHUNT REGULATOR BM432(BM431L)

Typical Performance Characteristics

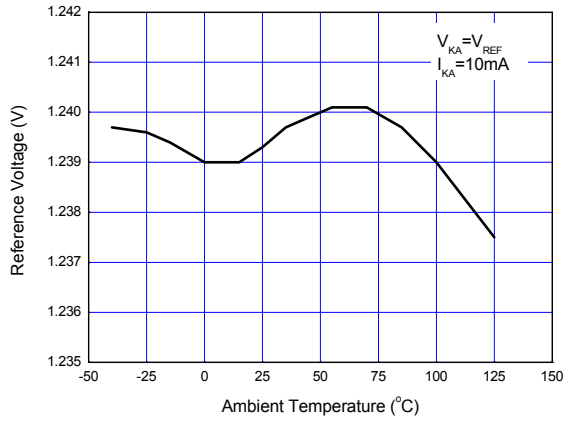

Figure 7. Reference Voltage vs. Ambient Temperature

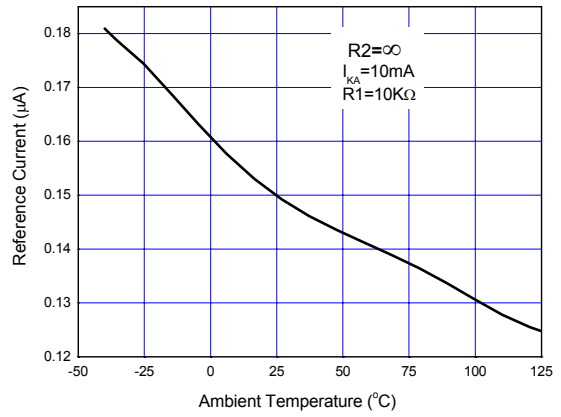

Figure 8. Reference Current vs. Ambient Temperature

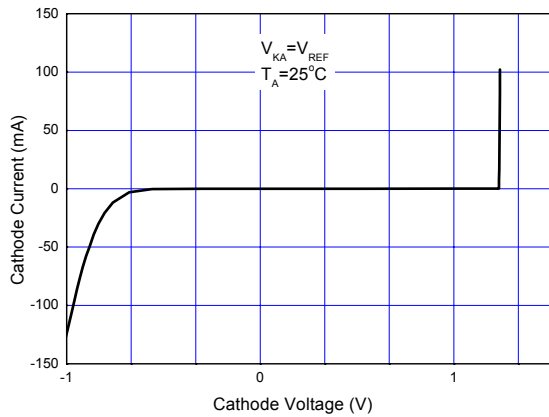

Figure 9. Cathode Current vs. Cathode Voltage

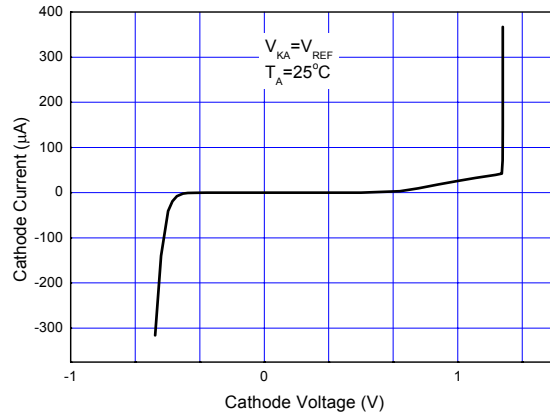

Figure 10. Current vs. Cathode Voltage

LOW VOLTAGE (1.24V) ADJUSTABLE PRECISION SHUNT REGULATOR **BM432(BM431L)**

Typical Performance Characteristics (Continued)

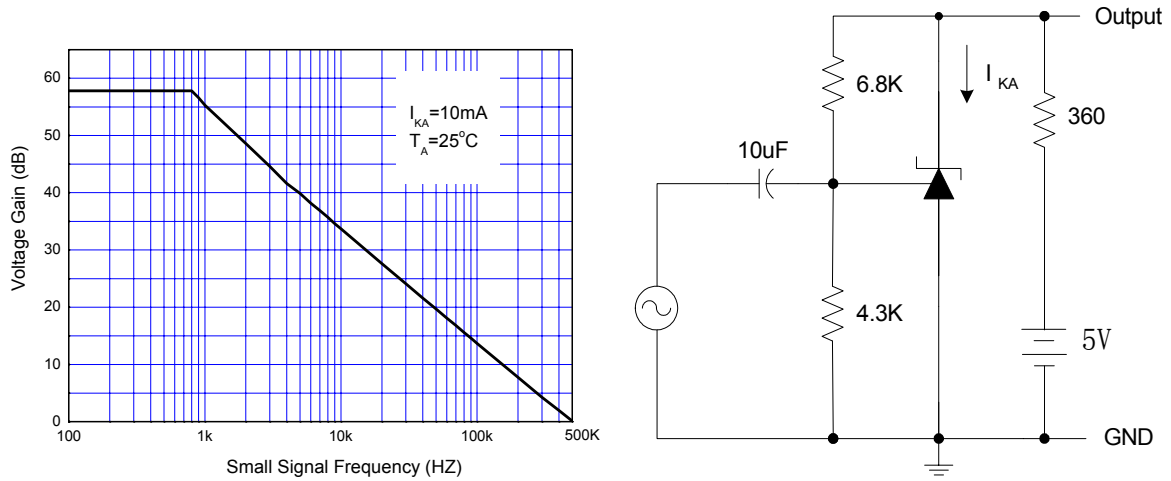

Figure 11. Small Signal Voltage Gain vs. Frequency

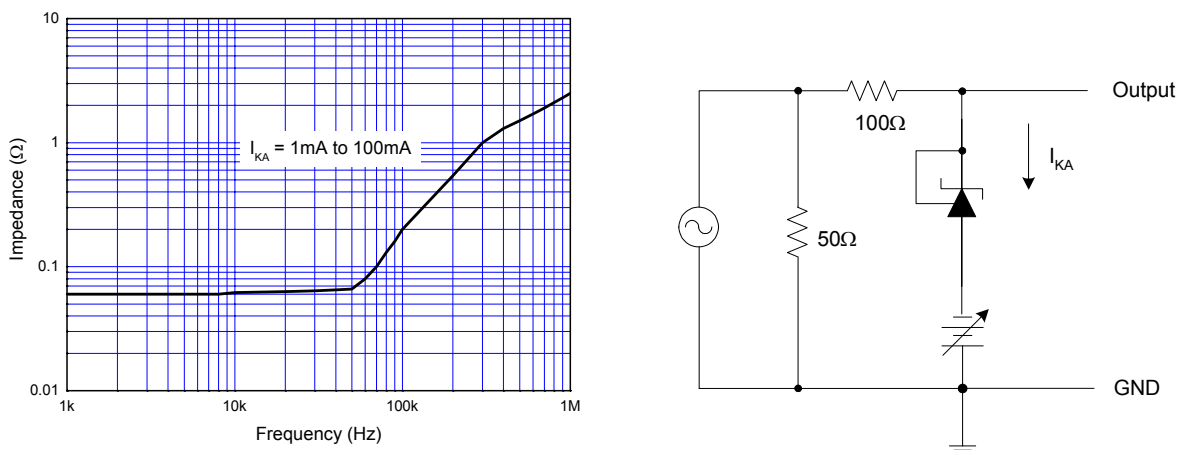

Figure 12. Dynamic Impedance vs. Frequency

LOW VOLTAGE (1.24V) ADJUSTABLE PRECISION SHUNT REGULATOR BM432(BM431L)

Typical Performance Characteristics (Continued)

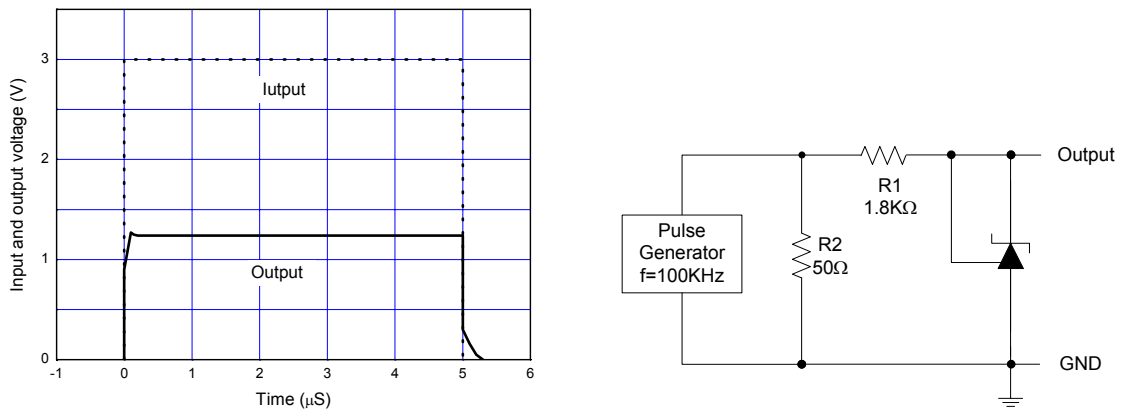

Figure 13. Pulse Response of Input and Output Voltage

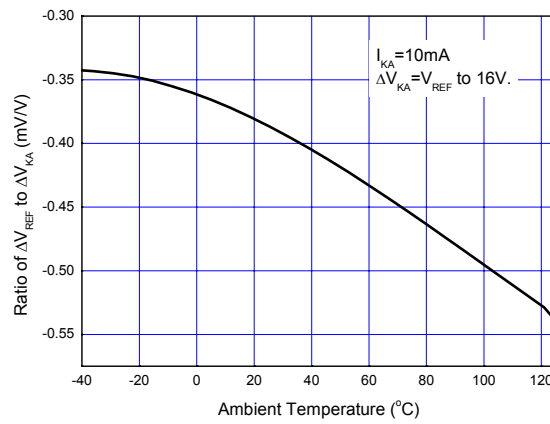

Figure 14. Ratio of Delta Reference Voltage to the Ratio of Cathode Voltage vs. Ambient Temperature

Typical Applications

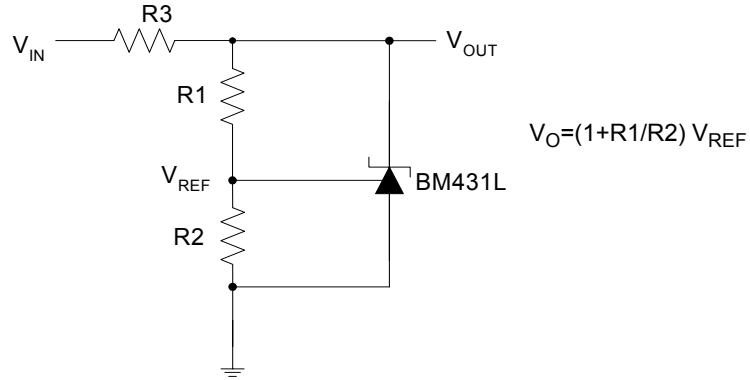

Figure 15. Shunt Regulator

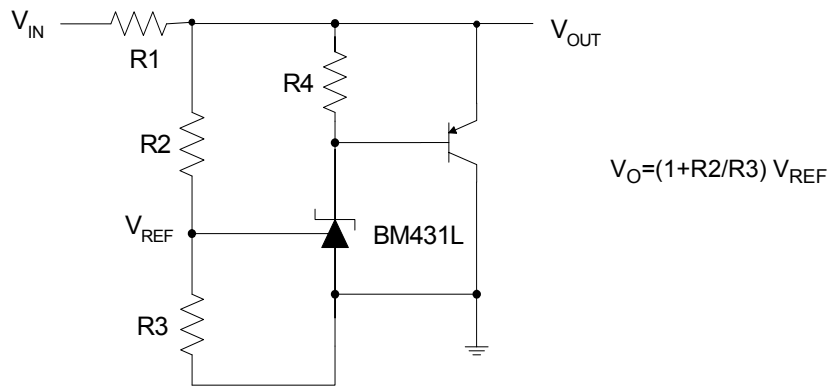

Figure 16. High Current Shunt Regulator

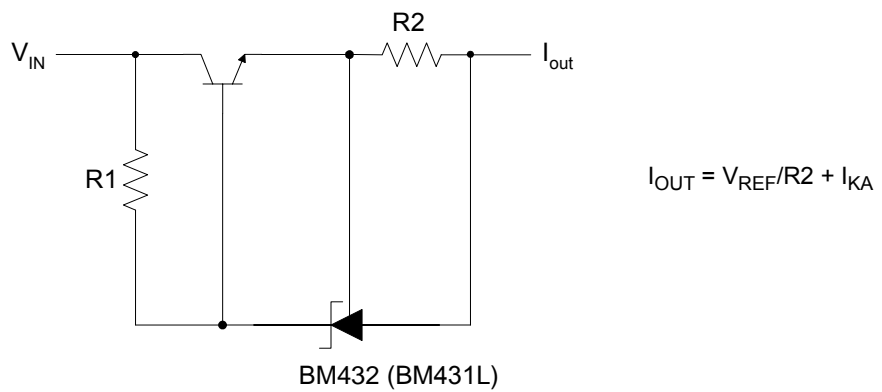

Figure 17. Current Source or Current Limit

LOW VOLTAGE (1.24V) ADJUSTABLE PRECISION SHUNT REGULATOR **BM432(BM431L)**

Typical Applications (Continued)

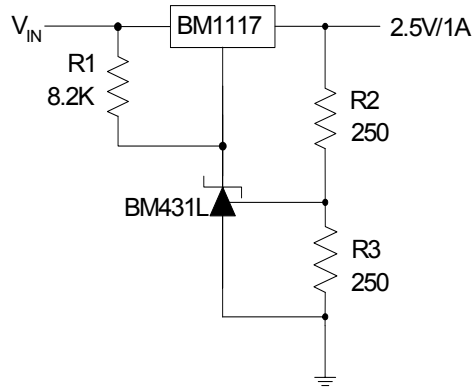

Figure18. Precision 5-V 1.5A Regulator

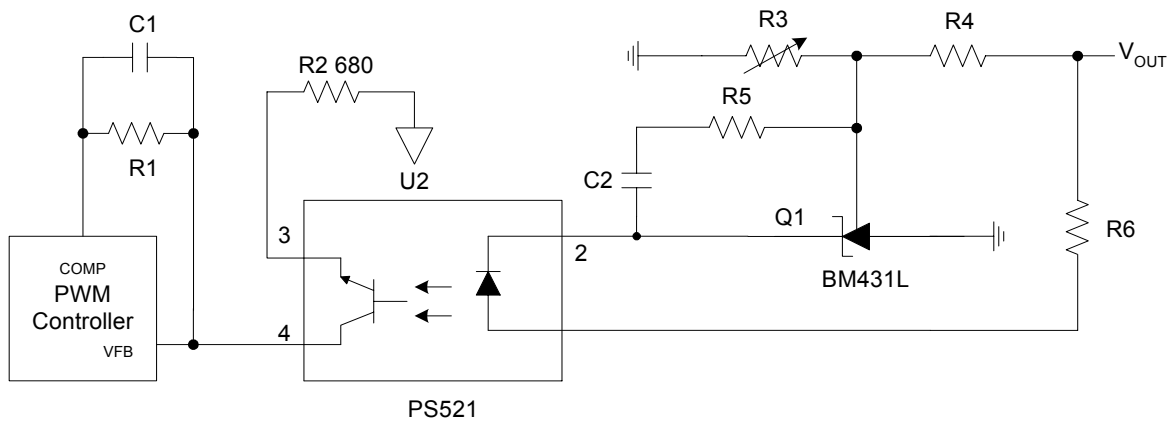
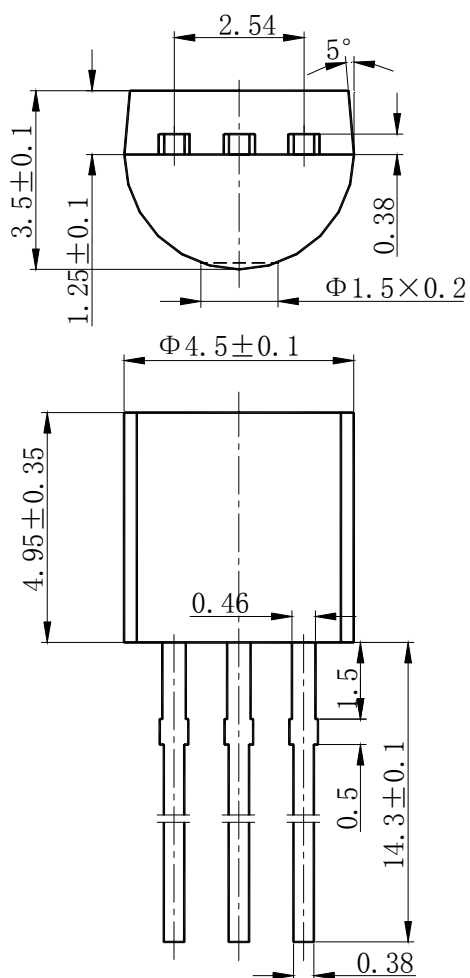

Figure 19. PWM Converter with Reference

Mechanical Dimensions

TO - 92

Unit: mm



Mechanical Dimensions (Continued)

SOT - 23 - 5

Unit: mm

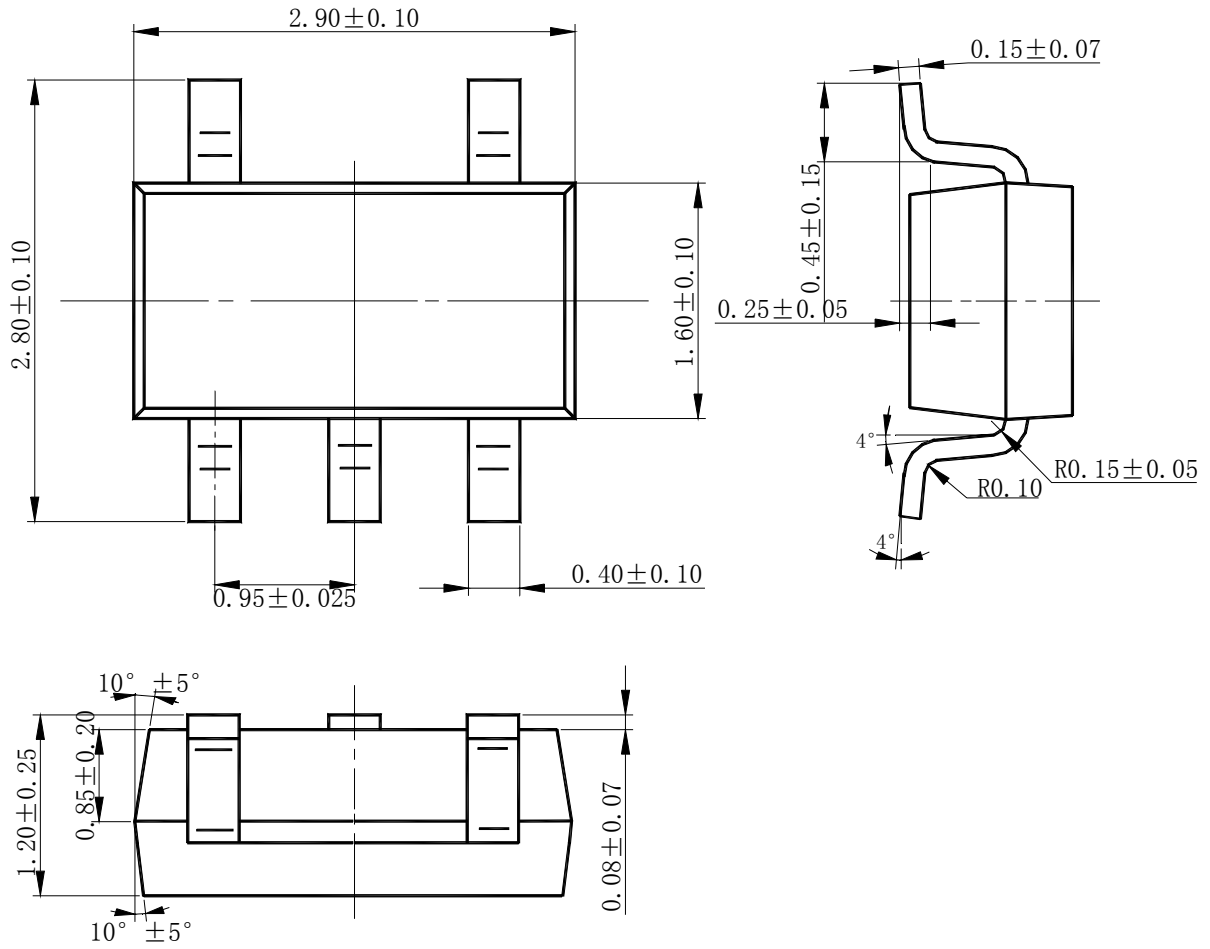

Mechanical Dimensions (Continued)

SOT - 89

Unit: mm

