

GENERAL DESCRIPTION

The BM9230 family is a positive voltage linear low dropout regulator developed utilizing CMOS technology featured low quiescent current (50µA typ.), low dropout voltage, and high output voltage accuracy. Built-in low on-resistance transistor provides low dropout voltage and large output current. A 2.2µF or greater can be used as an output capacitor.

The SOT-23-3, SOT-23-5, and TO-92 miniaturized package and the SOT-89 package are recommended for configuring portable devices and large current application, respectively.

These robust devices are designed to prevent device failure under the worst operation condition with both Thermal Shutdown and Current Fold-back.

FEATURES

- ◆ Very Low Dropout Voltage
- ◆ Low Current Consumption: Typ. 50µA, Max. 60µA
- ◆ Output Voltage: 2.5V, 2.7V, 2.8V, 3.0V, 3.3V, 3.5V, 3.6V, and 3.8V
- ◆ High Accuracy Output Voltage: +/- 1.5%
- ◆ Guaranteed 600mA Output
- ◆ Input Range of 2.8V to +15.0V
- ◆ Thermal Shutdown
- ◆ Current Limiting
- ◆ Compact Package: SOT-23-3, and SOT-89
- ◆ G version means Pb-free in part number
- ◆ Short Circuit Current Fold-Back
- ◆ Low Temperature Coefficient

APPLICATIONS

- ◆ Portable DVD
- ◆ DSC , GPS
- ◆ USB-disc , MP4
- ◆ PC peripherals , Camera

Note : BM9230 is 600mA , and can up to 650mA , it mainly use SOT89 package. But need larger solder pad if big current output for SOT89 to heat-sink .

TYPICAL APPLICATIONS

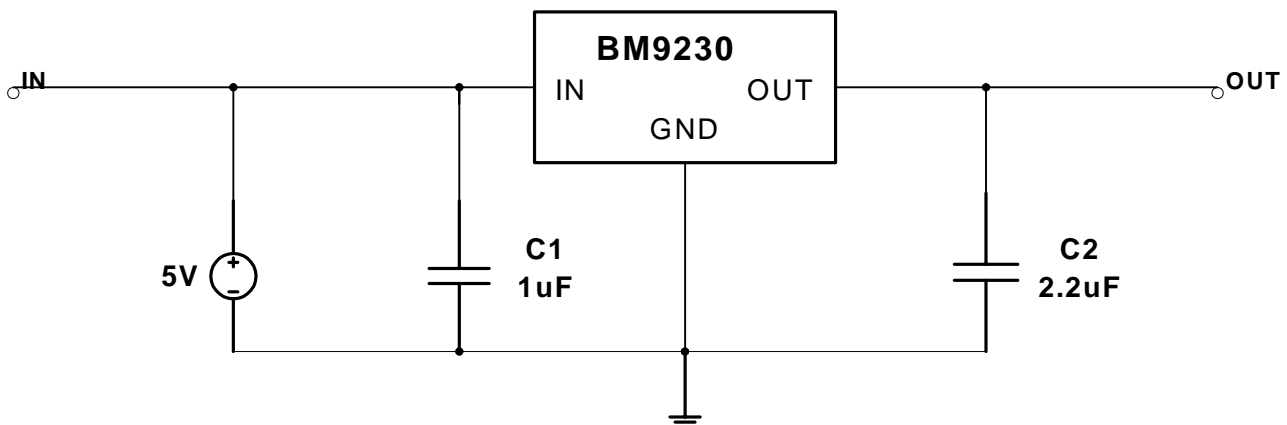

PIN CONFIGURATION

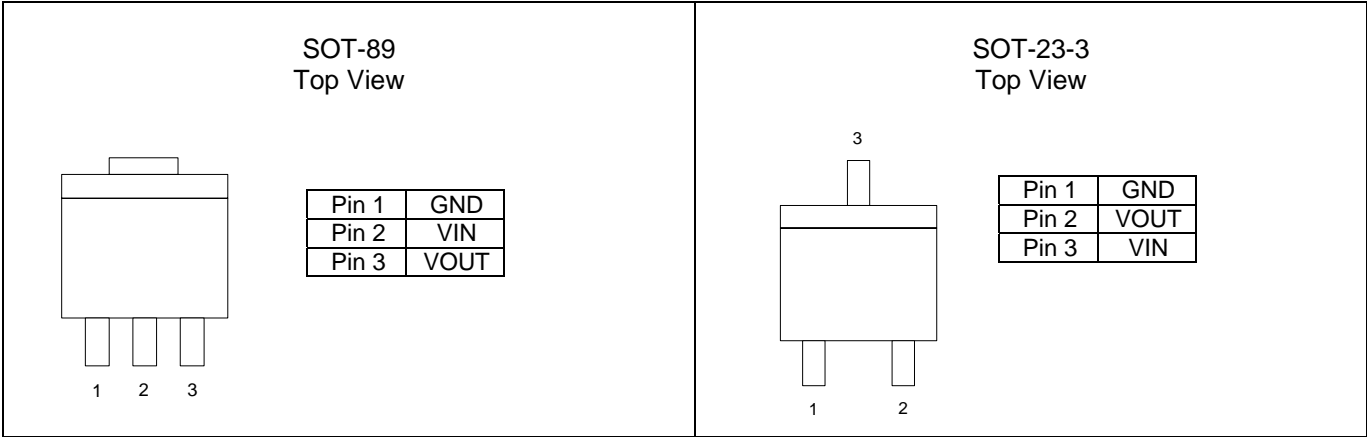

BLOCK DIAGRAM

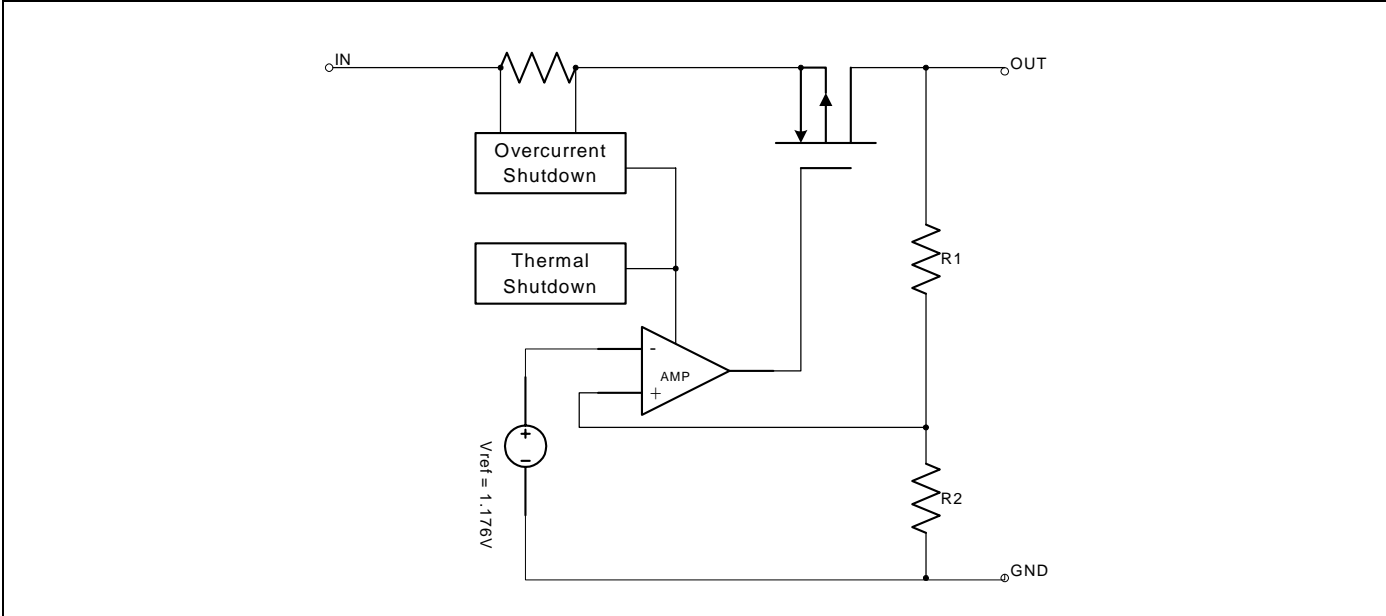

ABSOLUTE MAXIMUM RATINGS

Input Voltage +18V
 Output Current $P_D / (V_{IN} - V_O)$
 Output Voltage GND-0.3V to $V_{IN}+0.3V$
 ESD Classification B

OPERATING RATINGS

Ambient Temperature Range (T_A) -40°C to +85°C
 Junction Temperature Range -40°C to +125°C

THERMAL INFORMATION

Parameter		Maximum	Unit
Thermal Resistance (θ_{jc})	SOT-23-3	110	°C/W
	SOT-89	18	
Thermal Resistance (θ_{ja})	SOT-23-3	325	°C/W
	SOT-89	180	
Internal Power Dissipation (P_D) ($\Delta T = 100^\circ C$)	SOT-23-3	300	mW
	SOT-89	550	
Maximum Junction Temperature		150	°C
Maximum Lead Temperature (10 Sec)		300	°C

*With Junction sink capable of twice times of θ_{jc}

Caution: Stress above the listed absolute rating may cause permanent damage to the device.

Order information

BM9230XYZ order and lable information table:

X (package)	A	SOT89
	B	SOT23
Y (pb-free)	G	Pb-free
Z (volage)	D	1.8V
	K	2.5V
	N	2.7V
	P	3.0V
	S	3.3V
	Z	5.0V

BM9230 marking information table:

3X : 3 represent BM9230 and X (A or B) represent package

Y (D, K, N, P, S, Z) represent voltage

Smaller letters XX : first X is wafer data code, the second X is package datacode

ELECTRICAL CHARACTERISTICS

$T_A = +25^{\circ}\text{C}$; unless otherwise noted

Parameter	Test Conditions	BM9230			Unit
		Min.	Typ.	Max.	
Input Voltage		Note 1		15	V
Output Voltage Accuracy	$I_o = 1\text{mA to } 600\text{mA}$	-1.5		1.5	%
Dropout Voltage	$I_o=500\text{mA}, V_{OUT}=V_{OUT}-2.0\%, V_{OUT}>2.5\text{V}$		300		mV
	$I_o=500\text{mA}, V_{OUT}=V_{OUT}-2.0\%, V_{OUT}\leq 2.5\text{V}$		500		mV
Output Current	$V_{OUT} > 1.2\text{V}$		500		mA
Short Circuit Current	$V_{OUT} < 1.05\text{V}$		150	300	mA
Current Limit	$V_{OUT}>1.2\text{V}$ (BM9230)		700		mA
Quiescent Current	$V_{IN}=5\text{V}, \text{No Load}$		25	30	μA
Ground Pin Current	$I = 1\text{mA to } 600\text{mA}$		25	35	μA
Line Regulation	$I_{OUT}=5\text{mA}, V_{IN}=V_{OUT}+1 \text{ to } V_{OUT}+2, V_{OUT} \leq 3.0\text{V}$	-0.15	0.03	0.15	%
	$I_{OUT}=5\text{mA}, V_{IN}=V_{OUT}+1 \text{ to } V_{OUT}+2, V_{OUT} > 3.0\text{V}$	-0.3	0.06	0.3	
Load Regulation	$I_o=1\text{mA to } 600\text{mA}$		0.2	1	%
Power Supply Rejection	$I_o = 100\text{mA}$ $C_o=2.2\mu\text{F ceramic}$	$f=1\text{KHz}$		70	dB
		$f=10\text{KHz}$		60	
		$f=100\text{KHz}$		50	
Over Temperature Shutdown			150		$^{\circ}\text{C}$
Over Temperature Hystersis			30		$^{\circ}\text{C}$
Output Noise	$F=10\text{Hz to } 100\text{kHz}, C_o=2.2\mu\text{F}, I_o = 10\text{mA}$		25		μVrms
Output Voltage Temp. Coeff.			25		ppm/ $^{\circ}\text{C}$

Note 1. $V_{IN(MIN)} = V_{OUT} + 0.3\text{V}$

DETAILED DESCRIPTION

The BM9230 family of CMOS regulators contain a PMOS pass transistor, voltage reference, error amplifier, over-current protection, thermal shutdown, and short circuit protection.

The P-channel pass transistor receives data from the error amplifier, over-current shutdown, short output protection, and thermal protection circuits. During normal operation, the error amplifier compares the output voltage to a precision reference. Over-current and Thermal shutdown circuits become active when the junction temperature exceeds 150°C , or the current exceeds 700mA. During thermal shutdown, the output voltage remains low. Normal operation is restored when the junction temperature drops below 120°C .

The BM9230 switches from voltage mode to current mode when the load exceeds the rated output current. This prevents over-stress. They also incorporates current fold-back to reduce power dissipation when the output is short-circuited. This feature becomes active when the output drops below 1.05V, and reduces the current flow by 65%. Full current is restored when the voltage exceeds 1.05V.

EXTERNAL CAPACITOR

The BM9230 is stable with an output capacitor to ground of $2.2\mu\text{F}$ or greater. It can keep stable even with higher or poor ESR capacitors. A second capacitor is recommended between the input and ground to stabilize V_{IN} . The input capacitor should be larger than $0.1\mu\text{F}$ to have a beneficial effect. All capacitors should be placed in close proximity to the pins. A "quiet" ground termination is desirable.

TYPICAL ELECTRICAL CHARACTERISTICS

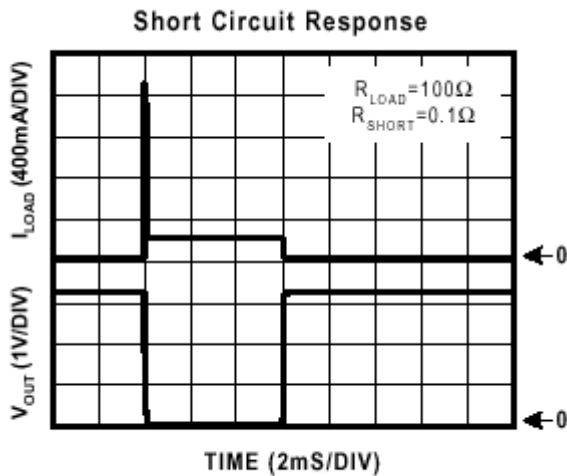
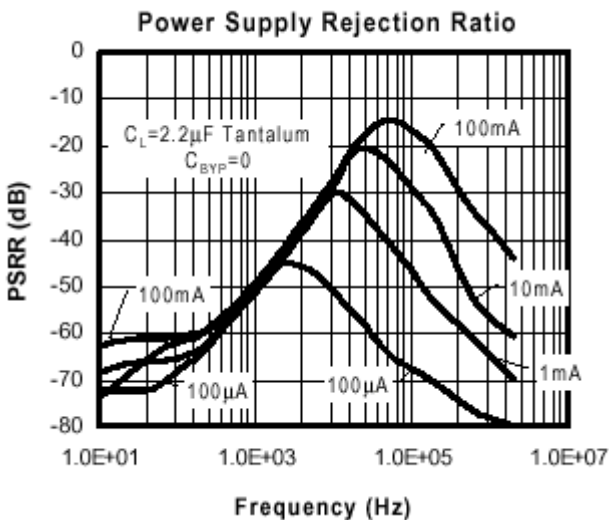
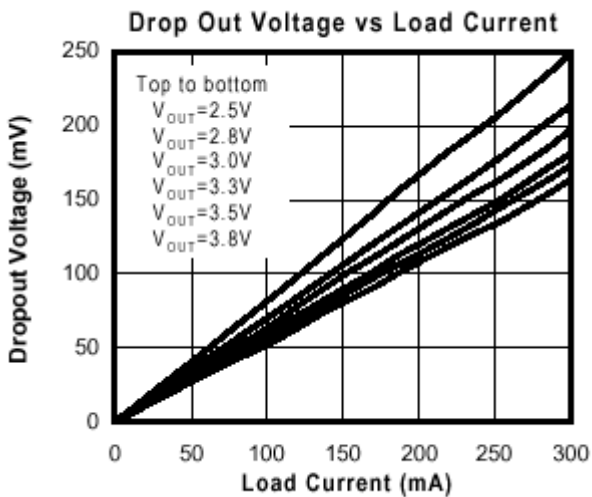
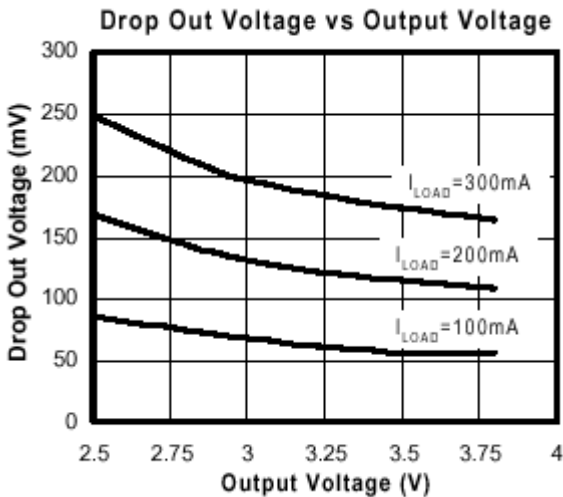
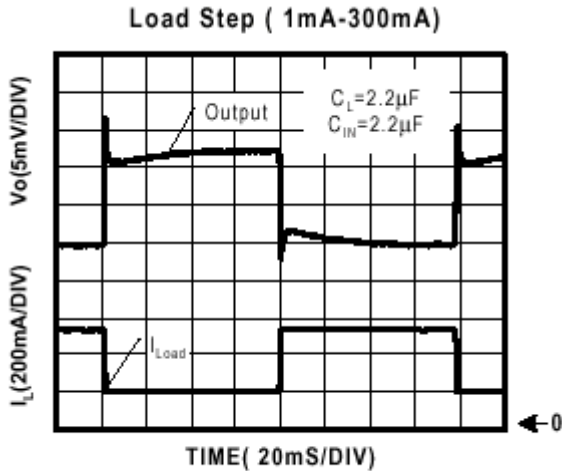
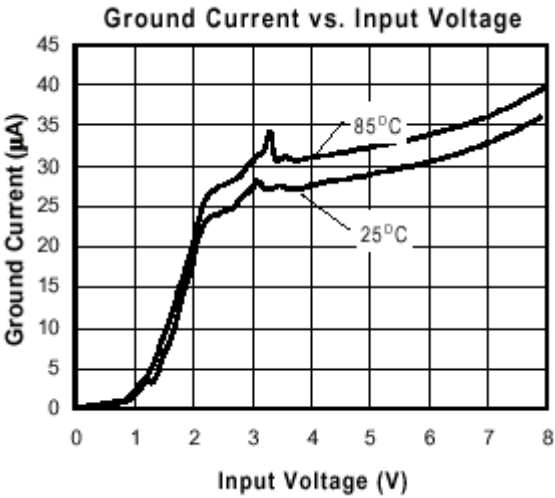

Overtemperature Shutdown

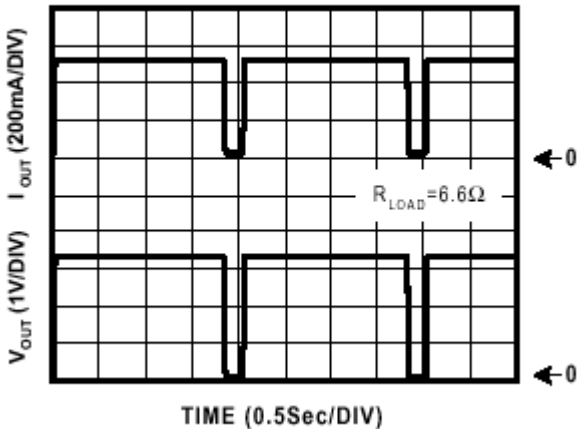

Current Limit Response

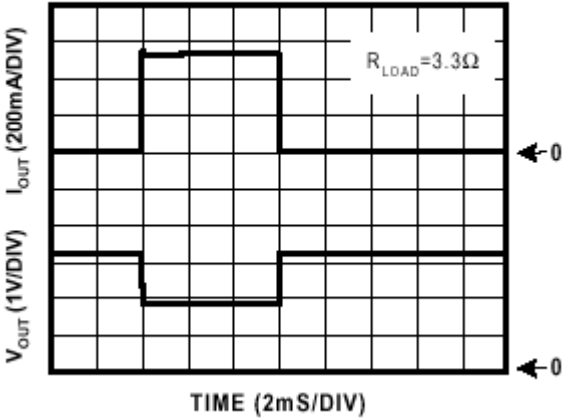

Noise Measurement

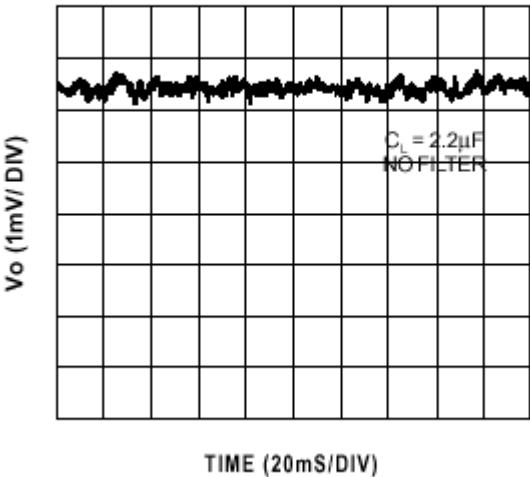

Transient Line Response

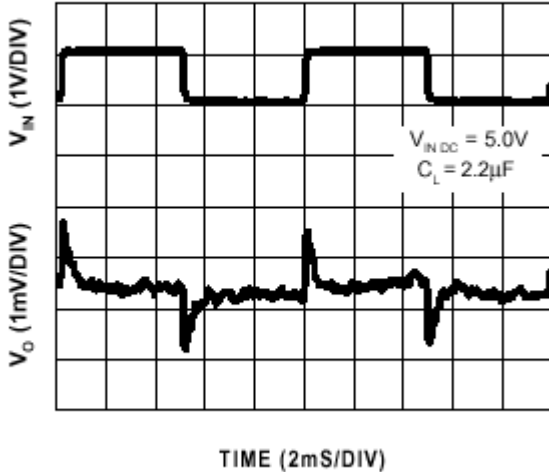

Safe Operating Area

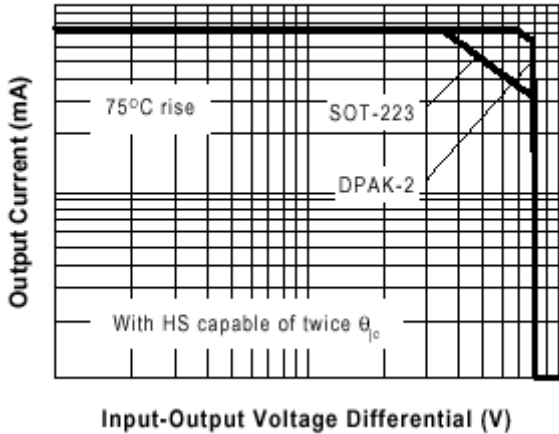

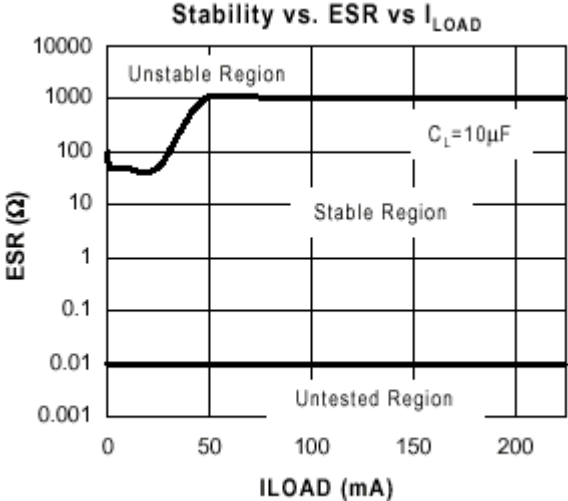
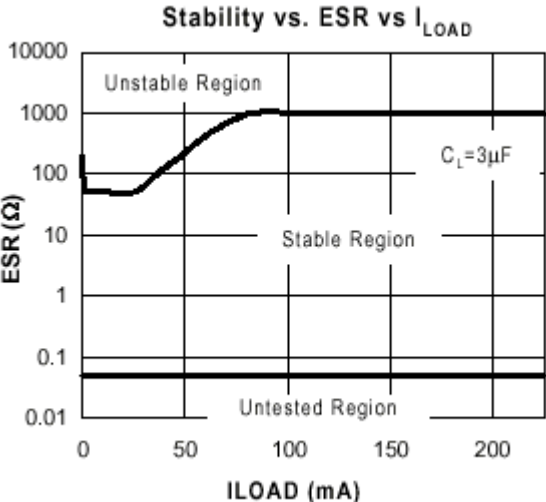
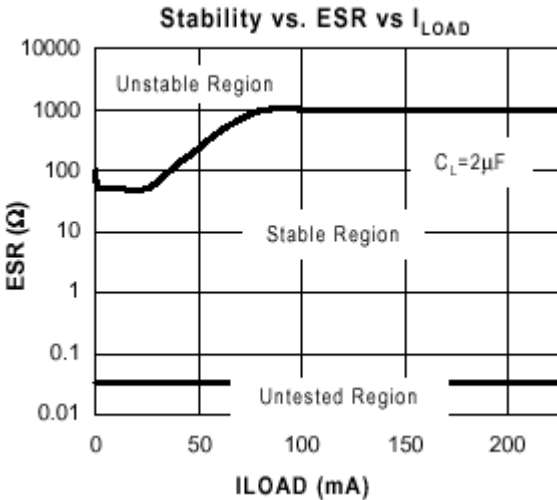
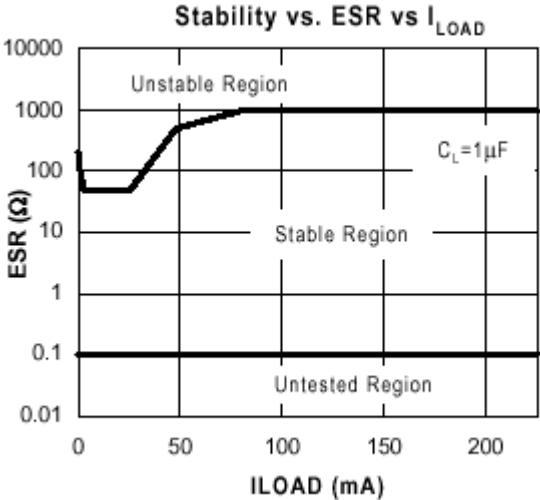

PACKAGE DIMENSION

SOT-23-3 (M23)

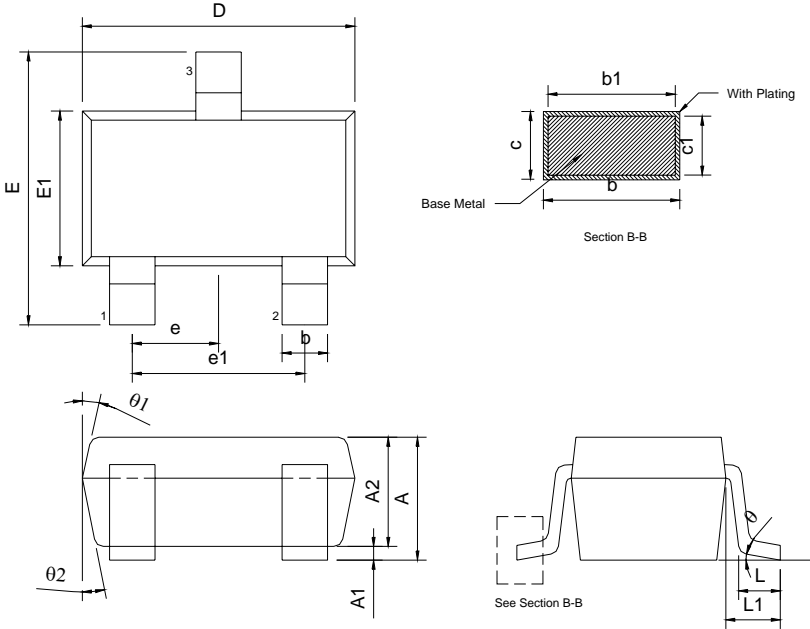

SYMBOLS	DIMENSIONS IN MILLIMETERS			DIMENSIONS IN INCHES		
	MIN	NOM	MAX	MIN	NOM	MAX
A	1.05	---	1.35	0.041	---	0.053
A1	0.05	---	0.15	0.002	---	0.006
A2	1.00	1.10	1.20	0.039	0.043	0.047
b	0.25	---	0.50	0.010	---	0.020
b1	0.25	0.40	0.45	0.010	0.016	0.018
c	0.08	---	0.20	0.003	---	0.008
c1	0.08	0.11	0.15	0.003	0.004	0.006
D	2.70	2.90	3.00	0.106	0.114	0.118
E	2.60	2.80	3.00	0.102	0.110	0.118
E1	1.50	1.80	1.70	0.059	0.083	0.087
L	0.35	0.45	0.55	0.014	0.018	0.022
L1	0.60 REF			0.024 REF		
e	0.95 BSC			0.037 BSC		
e1	1.90 BSC			0.075 BSC		
theta	0°	5°	10°	0°	5°	10°
theta1	3°	5°	7°	3°	5°	7°
theta2	6°	8°	10°	6°	8°	10°

SOT-89 (M89)

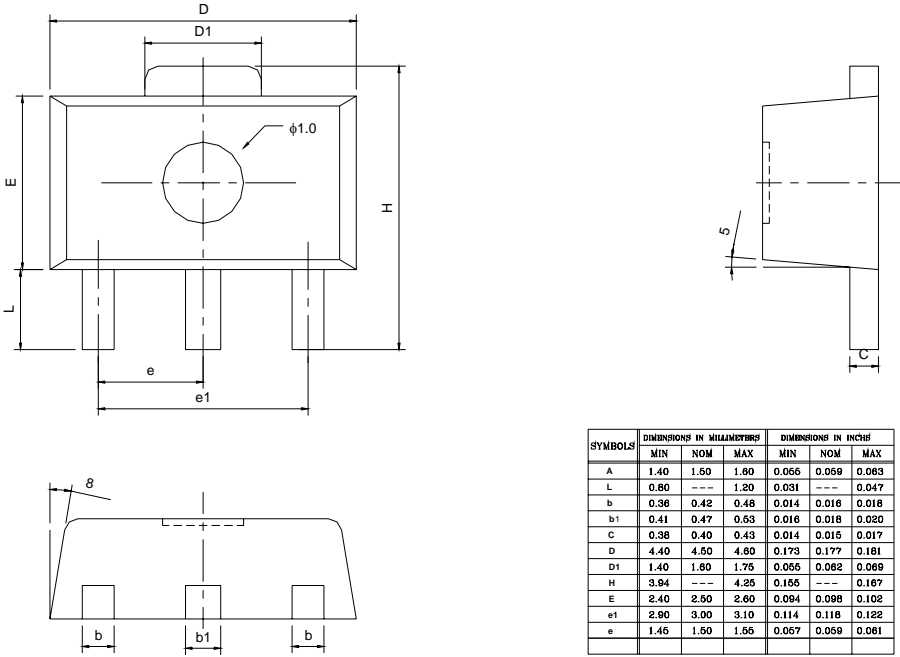

SYMBOLS	DIMENSIONS IN MILLIMETERS			DIMENSIONS IN INCHES		
	MIN	NOM	MAX	MIN	NOM	MAX
A	1.40	1.60	1.60	0.055	0.059	0.063
L	0.80	---	1.20	0.031	---	0.047
b	0.38	0.42	0.48	0.014	0.016	0.018
b1	0.41	0.47	0.53	0.016	0.018	0.020
C	0.38	0.40	0.43	0.014	0.015	0.017
D	4.40	4.50	4.80	0.173	0.177	0.181
D1	1.40	1.80	1.75	0.055	0.082	0.089
H	3.84	---	4.25	0.155	---	0.167
E	2.40	2.50	2.80	0.094	0.098	0.102
e1	2.80	3.00	3.10	0.114	0.118	0.122
e	1.46	1.50	1.55	0.057	0.059	0.061