

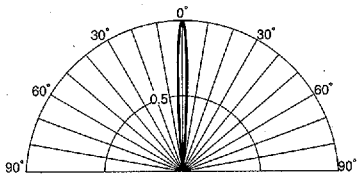









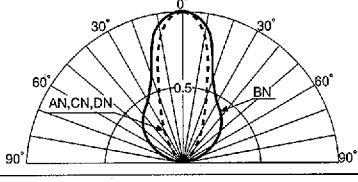

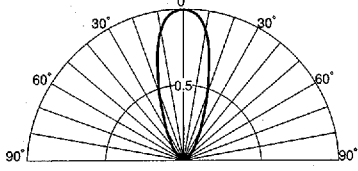

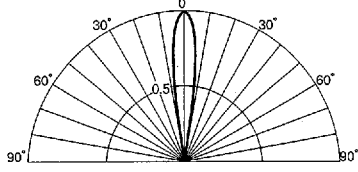

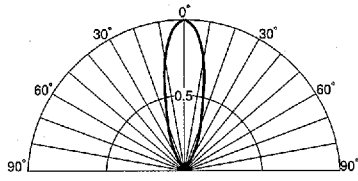
SUPER INTENSITY INFRARED LED

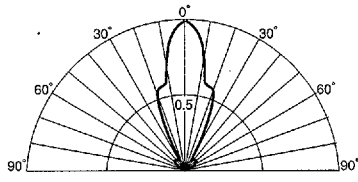
CHARACTERISTICS BY SHAPE

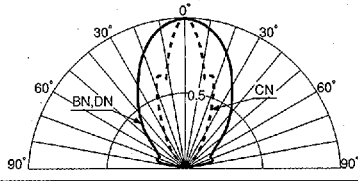
Ta=25°C

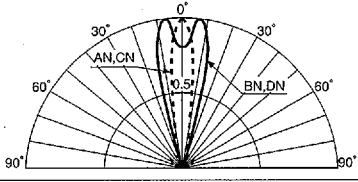
Shape	Type No	Peak Wavelength λ_p		Radiant Intensity I_r			Output Power P_o		Cut-Off Frequency F_c		Spatial Distribution (The typical Distribution example of each shape is shown below)	Fig.
		TYP	IF	MIN	TYP	IF	TYP	IF	TYP	IF		
	AN106	950	50	15	25	50	3.5	50	0.5	50		9
	BN106	925	20	2.0	4.0	20	—	—	1.8	20		
	CN106	880	50	20	30	50	4.5	50	0.65	50		
	DN106	850	50	25	70	50	7	50	30	50		
	AN202	950	50	1.5	2.5	50	4	50	0.5	50		10
	BN202	925	20	0.15	0.3	20	—	—	1.8	20		
	CN202	880	50	2.0	3.0	50	5	50	0.65	50		
	DN202	850	50	2.5	4.0	50	8	50	30	50		
	AN304	950	50	6	15	50	9	50	0.5	50		11
	CN304	880	50	10	20	50	9	50	0.65	50		
	DN304	850	50	15	30	50	15	50	30	50		
	AN305	950	50	10	25	50	8	50	0.5	50		12
	BN301	925	20	3	7	20	—	—	1.8	20		
	CN305	880	50	15	30	50	8	50	0.65	50		12
	DN305	850	50	25	80	50	12	50	30	50		
	AN306	950	50	7	14	50	5	50	0.5	50		14
	BN306	925	20	1.3	2.6	20	1	20	1.8	20		
	CN306	880	50	9	18	50	7	50	0.65	50		15
	DN319	850	50	10	20	50	8	50	30	50		
	AN501	950	50	3	5	50	6	50	0.5	50		16
	BN501	925	20	0.5	1.5	20	—	—	1.8	20		
	CN501	880	50	3	6	50	9	50	0.65	50		
	DN501	850	50	5.2	10.4	50	10	50	30	50		
	BN504	925	20	0.5	1	20	—	—	1.8	20		17
	CN504	880	50	3	5	50	7	50	0.65	50		
	DN504	850	50	4	8	50	12	50	30	50		
	AN505	950	50	2	4	50	6	50	0.5	50		18
	BN505	925	20	0.5	1.5	20	—	—	1.8	20		
	CN505	880	50	2.5	5	50	7	50	0.65	50		
	DN505	850	50	4	8	50	12	50	30	50		
	AN1102W	950	20	0.5	0.8	20	2	20	0.5	20		19
	DN1102W	850	20	0.8	1.6	20	4	20	30	20		

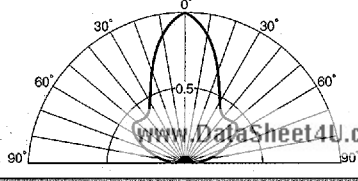
Units

nm

mA

mW/sr

mA

mW

mA

MHz

mA

▼PACKAGE DIMENSIONS Unit : mm

fig. 9

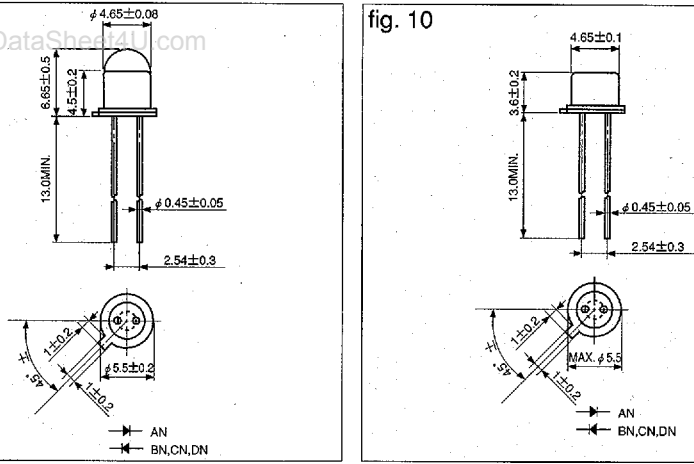

fig. 10

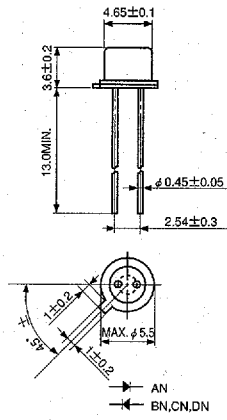

fig. 11

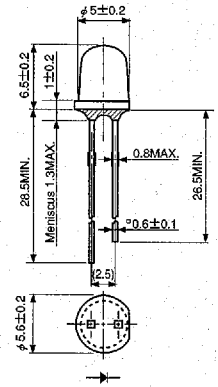

fig. 12

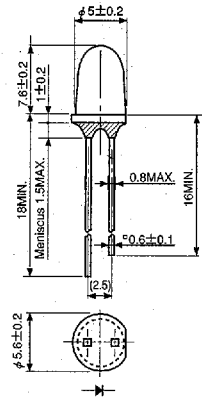

fig. 13

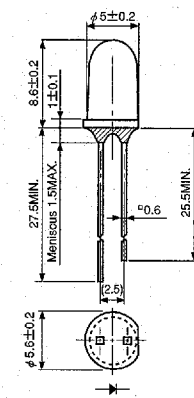

fig. 14

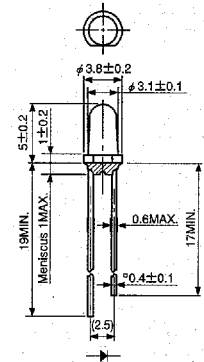

fig. 15

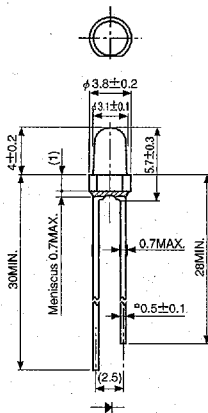

fig. 16

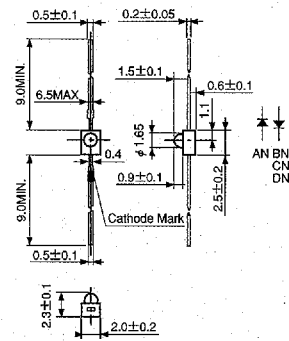

fig. 17

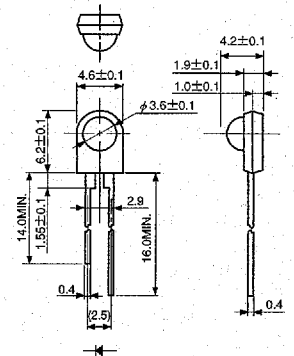

fig. 18

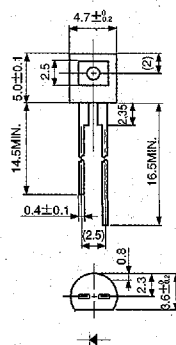

fig. 19

