

### Description

The BP2838 is a high precision buck constant current LED driver. The device operates in critical conduction mode and is suitable for 85Vac~265Vac universal input offline LED lighting.

The BP2838 integrates a 500V power MOSFET. With patent pending MOSFET driving technique, the operating current of the IC is very low. It doesn't need the auxiliary winding for supplying the chip. It can achieve excellent constant current performance with very few external components, so the system cost and size are minimized.

The BP2838 utilizes patent pending current control method. It can achieve precise output current and excellent line regulation. The driver operates in critical conduction mode, the output current does not change with the inductance and LED output voltage.

The BP2838 offers rich protection functions to improve the system reliability, LED short circuit protection, VCC under voltage protection, CS resistor short circuit protection and thermal regulation function.

### Typical Application

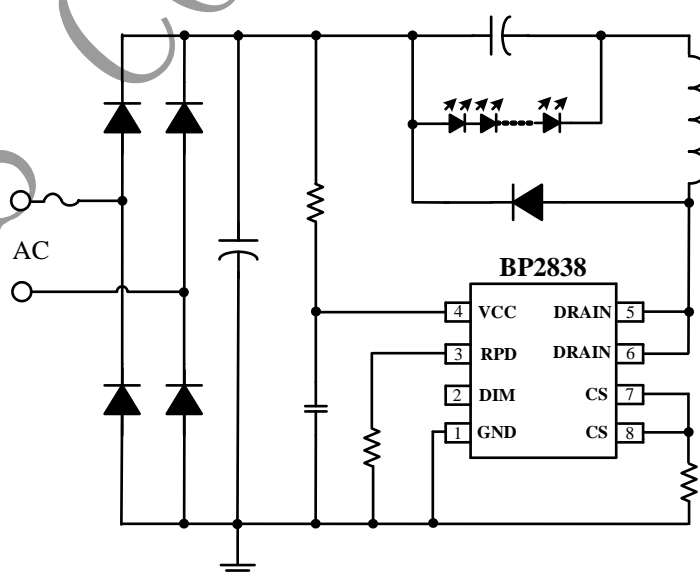

Figure 1. Typical application circuit for BP2838

### Features

- Critical Conduction Mode Operation
- Internal 500V Power MOSFET
- No Auxiliary Winding
- Ultra Low Operating Current
- $\pm 5\%$  LED Output Current Accuracy
- PWM dimmable
- LED Short Protection
- Current Sensing Resistor Short Protection
- VCC Under Voltage Protection
- Thermal Regulation Function
- Available in SOP8 Package

### Applications

- LED Candle Light
- LED Bulb
- Other LED Lighting

### Ordering Information

Part Number	Package	Operating Temperature	Packing Method	Marking
BP2838	SOP8	-40 °C to 105 °C	Tape 4,000 Piece/Reel	BP2838 XXXXXY WWXY

### Pin Configuration and Marking Information

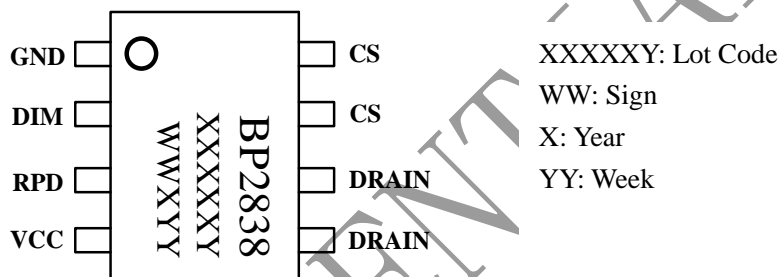

Figure 2. Pin configuration

### Pin Definition

Pin No.	Name	Description
1	GND	Ground
2	DIM	PWM dimming input, need a 10k ohms resistor in series
3	RPD	Pull down enable, connect a 10k ohms resistor to GND
4	VCC	Power Supply Pin
5,6	DRAIN	Internal HV Power MOSFET Drain
7,8	CS	Current Sense Pin. Connect a sense resistor between this pin and GND pin.

**Absolute Maximum Ratings (note1)**

Symbol	Parameters	Range	Units
I <sub>CC_MAX</sub>	VCC pin maximum sink current	5	mA
DRAIN	Internal HV MOSFET drain voltage	-0.3~500	V
CS	Current sense pin input voltage	-0.3~6	V
DIM	PWM dimming input	-0.3~6	V
RPD	Pull down enable	-0.3~6	V
P <sub>DMAX</sub>	Power dissipation (note 2)	0.45	W
θ <sub>JA</sub>	Thermal resistance (Junction to Ambient)	145	°C/W
T <sub>J</sub>	Operating junction temperature	-40 to 150	°C
T <sub>STG</sub>	Storage temperature range	-55 to 150	°C
	ESD (note 3)	2	kV

**Note 1:** Stresses beyond those listed under “absolute maximum ratings” may cause permanent damage to the device. Under “recommended operating conditions” the device operation is assured, but some particular parameter may not be achieved. The electrical characteristics table defines the operation range of the device, the electrical characteristics is assured on DC and AC voltage by test program. For the parameters without minimum and maximum value in the EC table, the typical value defines the operation range, the accuracy is not guaranteed by spec.

**Note 2:** The maximum power dissipation decrease if temperature rise, it is decided by T<sub>JMAX</sub>, θ<sub>JA</sub>, and environment temperature (T<sub>A</sub>). The maximum power dissipation is the lower one between P<sub>DMAX</sub> = (T<sub>JMAX</sub> - T<sub>A</sub>) / θ<sub>JA</sub> and the number listed in the maximum table.

**Note 3:** Human Body mode, 100pF capacitor discharge on 1.5kΩ resistor

**Recommended Operation Conditions**

Symbol	Parameter	Range	Unit
I <sub>LED1</sub>	Output LED current @ V <sub>out</sub> =72V (Input voltage 176V~265V)	280	mA
I <sub>LED2</sub>	Output LED current @ V <sub>out</sub> =36V (Input voltage 176V~265V)	350	mA
V <sub>LED_min</sub>	Minimum LED Loading Voltage	>25	V

**Electrical Characteristics (Notes 4, 5)** (Unless otherwise specified,  $V_{CC}=15V$  and  $T_A=25\text{ }^\circ\text{C}$ )

Symbol	Parameter	Conditions	Min	Typ	Max	Units
<b>Supply Voltage Section</b>						
$V_{CC\_CLAMP}$	$V_{CC}$ Clamp Voltage	1mA		17		V
$V_{CC\_ON}$	$V_{CC}$ Turn On Threshold	$V_{CC}$ Rising		14		V
$V_{CC\_UVLO}$	$V_{CC}$ Turn off Threshold	$V_{CC}$ Falling		9		V
$I_{ST}$	$V_{CC}$ Startup Current	$V_{CC}=V_{CC\_ON}-1V$		120	180	$\mu\text{A}$
$I_{OP}$	$V_{CC}$ Operating Current	$F_{OP}=70\text{KHz}$		150	200	$\mu\text{A}$
<b>Current Sense Section</b>						
$V_{CS\_TH}$	Threshold Voltage for Peak Current Limit		388	400	412	mV
$T_{LEB}$	Leading Edge Blanking Time for Current Sense			350		ns
$T_{DELAY}$	Switch Off Delay Time			200		ns
<b>Internal Time Control Section</b>						
$T_{OFF\_MIN}$	Minimum OFF Time			3		$\mu\text{s}$
$T_{OFF\_MAX}$	Maximum OFF Time			330		$\mu\text{s}$
$T_{ON\_MAX}$	Maximum On Time			40		$\mu\text{s}$
$V_{RPD}$	RPD Voltage			0.5		V
<b>MOSFET Section</b>						
$R_{DS\_ON}$	Static Drain-source On-resistance	$V_{GS}=15V/I_{DS}=0.4A$		5		$\Omega$
$BV_{DSS}$	Drain-Source Breakdown Voltage	$V_{GS}=0V/I_{DS}=250\mu\text{A}$	500			V
$I_{DSS}$	Power MOSFET Drain Leakage Current	$V_{GS}=0V/V_{DS}=500V$			1	$\mu\text{A}$
<b>PWM dimmable</b>						
$f_{DIM}$	PWM frequency range		0.1		10	kHz
<b>Thermal Regulation Section</b>						
$T_{REG}$	Thermal Regulation Temperature			150		$^\circ\text{C}$

Note 4: production testing of the chip is performed at 25  $^\circ\text{C}$ .

Note 5: the maximum and minimum parameters specified are guaranteed by test, the typical value are guaranteed by design, characterization and statistical analysis

### Internal Block Diagram

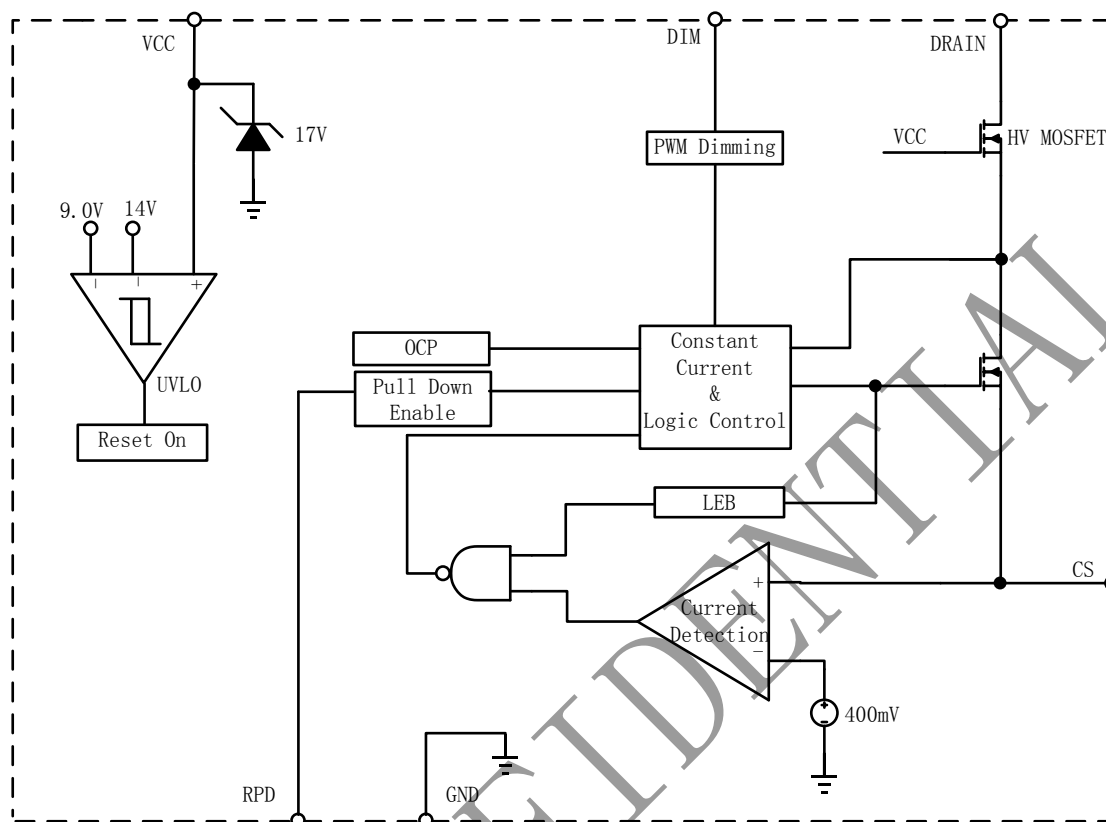

Figure 3. BP2838 Internal Block Diagram

### Application Information

The BP2838 is a high performance non-isolated Buck converter specially designed for LED lighting. The device integrates a 500V power MOSFET. With very few external components, the converter achieves excellent constant current control. And it does not need auxiliary winding for powering the IC or voltage sensing, hence the system size and cost is greatly reduced.

#### Start Up

After system powered up, the VCC pin capacitor is charged up by the start up resistor. When the VCC pin voltage reaches the turn on threshold, the internal circuits start operating. The BP2838 integrates a 17V zener diode to clamp the VCC voltage. Due to the ultra-low operating current, the auxiliary winding is not needed to supply the IC.

#### Constant Current Control

Cycle by Cycle current sense is adopted in BP2838, the CS pin is connected to the current sense comparator, and the voltage on CS pin is compared with the internal 400mV reference voltage. The MOSFET will be switched off when the voltage on CS pin reaches the threshold. The CS comparator includes a 350ns leading edge blanking time.

The peak inductor current is given by:

$$I_{PK} = \frac{400}{R_{CS}} \text{ (mA)}$$

Where,  $R_{CS}$  is the current sense resistor value.

The current in LED can be calculated by the equation:

$$I_{LED} = \frac{I_{PK}}{2}$$

Where,  $I_{PK}$  is the peak current of the inductor.

### Inductor Selection

The BP2838 works under inductor current critical conduction mode. When the power MOSFET is switched on, the current in the inductor rises up from zero, the on time of the MOSFET can be calculated by the equation:

$$t_{on} = \frac{L \times I_{PK}}{V_{IN} - V_{LED}}$$

Where,

L is the inductance value

$V_{IN}$  is the DC bus voltage after the rectifier bridge

$V_{LED}$  is the voltage on the LED

After the power MOSFET is switched off, the current in the inductor decreases. When the inductor current reaches zero, the power MOSFET is turned on again by IC internal logic. The off time of the MOSFET is given by:

$$t_{off} = \frac{L \times I_{PK}}{V_{LED}}$$

The inductance can be calculated by the equation:

$$L = \frac{V_{LED} \times (V_{IN} - V_{LED})}{f \times I_{PK} \times V_{IN}}$$

The f is the system switching frequency, which is proportional to the input voltage. So the minimum switching frequency is set at lowest input voltage, and the maximum switching frequency is set at highest input voltage.

The minimum and maximum off time of BP2838 is set at 3us and 330us, respectively. Referring to the equation of  $t_{OFF}$  calculation, if the inductance is too small, the  $t_{OFF}$  may be smaller than the minimum off

time, system will operate in discontinuous conduction mode and the output current will be smaller than the designed value. If the inductance is too large, the  $t_{OFF}$  may be larger than the maximum off time, the system will operate in continuous conduction mode and the output current will be higher than the designed value. So it is important to choose a proper inductance.

### PWM Dimming

BP2838 has DIM interface to support PWM dimming, and there need a series resistor. In the condition of PWM dimming, the enable level is higher than 0.5V; the possible PWM frequency is about 100Hz~10kHz; the LED current will follow the duty of PWM single from 0%~100%.

### Protection Function

The BP2838 offers rich protection functions to improve the system reliability, including short protection, CS resistor short protection,  $V_{CC}$  under voltage protection, thermal regulation.

When the LED short circuit is detected, the system works at ultra low frequency of 3kHz. So the system power consumption is very low. At some catastrophic fault condition, such as CS resistor shorted or inductor saturated, the internal fast fault detection circuit will be triggered, the system stops switching immediately.

After the system enters into fault condition, the VCC voltage will decrease until it reaches the UVLO threshold, then the system will re-start again.

### Thermal Regulation

The BP2838 integrates thermal regulation function. When the system is over temperature, the output current is gradually reduced; the output power and thermal dissipation are also reduced. The system temperature is regulated and the system reliability is improved. The thermal regulation temperature is set to 150°C internally.



### PCB Layout

The following rules should be followed:

#### Bypass Capacitor

The bypass capacitor on  $V_{CC}$  pin should be as close as possible to the  $V_{CC}$  Pin and GND pin.

#### RPD Pin

The RPD resistor should be as close as possible to the RPD Pin.

#### Ground Path

The power ground path for current sense should be short, and the power ground path should be separated from small signal ground path before connecting to the negative node of the bulk capacitor.

#### The Area of Power Loop

The area of main current loop should be as small as possible to reduce EMI radiation, such as the inductor, the power MOSFET, the output diode and the bus capacitor loop.

#### Drain Pin

To increase the copper area of DRAIN pin for better thermal dissipation. However too large copper area may compromise EMI performance.

### Physical Dimensions

