

Description

The BP3122B is a high precision primary-side feedback and regulation controller for LED lighting, it operates in constant current control mode and is designed to work in inductor current discontinuous conduction mode and especially suitable for flyback convertor under universal input. The output power of system is recommended to less than 5W.

The BP3122B integrates 650V power MOSFET. Since adopting primary sense and feedback control technology, the secondary sense and feedback circuit is eliminated. The loop compensation components are also removed while maintaining stability overall operating conditions. It uses patent pending source driver architecture and demagnetization sensing technology, the operating current is very low, and it doesn't need the auxiliary winding for sensing the output current and supplying the chip. The low component counts and small system size are realized.

Since using the proprietary high accurate current sense method, the BP3122B realizes $\pm 5\%$ accuracy of LED current along with excellent line and load regulation.

The BP3122B offers rich protection functions including LED open/short circuit protection, CS resistor short circuit protection, over-temperature protection, V_{CC} under voltage protection.

Features

- Built-in 650V Power MOSFET
- Constant current control without secondary sense and feedback circuit.
- No Auxiliary winding for sensing and supplying
- Ultra low operating current to improve efficiency
- Universal input voltage
- $\pm 5\%$ LED current accuracy
- LED short and open circuit protection
- CS resistor short circuit protection
- VCC under-voltage protection
- Over temperature protection
- Available in SOP8 package

Applications

- GU10/E27 LED bulb, spot light
- Other LED lighting

Typical Application

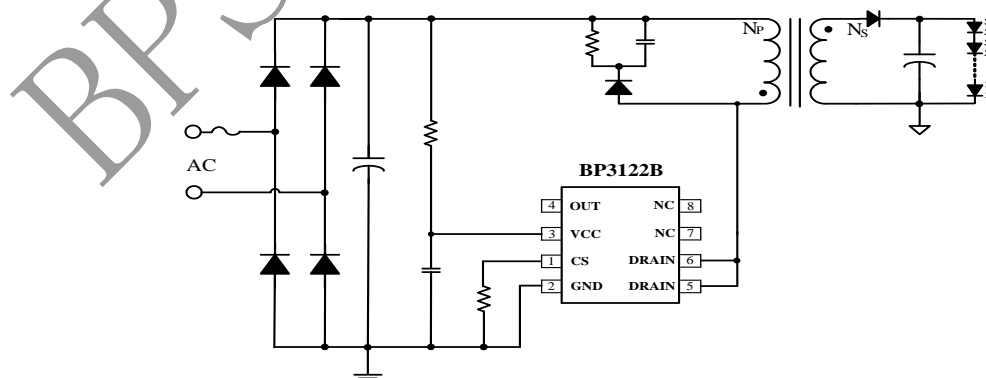

Figure 1. Typical application circuit for BP3122B

Ordering Information

Part Number	Package	Operating Temperature	Packing Method	Marking
BP3122B	SOP8	-40°C to 105°C	Tape 4,000 Piece/Reel	BP3122B XXXXXY WXY

Pin Configuration and Marking Information

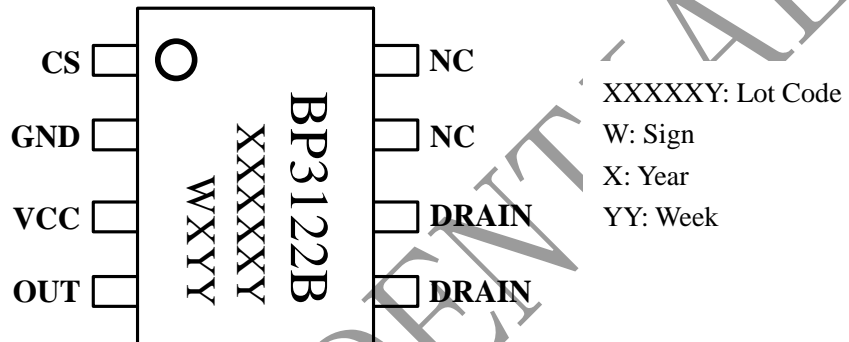

Figure 2. Pin configuration

Pin Definition

Pin No.	Name	Description
1	CS	Current sense. This pin connects a current sense resistor to GND to detect the primary current of transformer.
2	GND	Ground
3	VCC	Power supply
4	OUT	Internal high voltage MOSFET Source
5,6	DRAIN	Internal high voltage MOSFET Drain
7,8	NC	No connection, must be floated

Absolute Maximum Ratings (note1)

Symbol	Parameters	Range	Units
ICC_max	VCC pin maximum sink current	5	mA
DRAIN	Internal HV MOSFET drain voltage	-0.3~650	V
CS	Current sense pin input voltage	-0.3~6	V
OUT	Internal HV MOSFET Source voltage	-0.3~18	V
P _{DMAX}	Power dissipation (note2)	0.45	W
θ _{JA}	Thermal resistance (Junction to Ambient)	145	°C/W
T _J	Operating junction temperature	-40 to 150	°C
T _{STG}	Storage temperature range	-55 to 150	°C
	ESD (note3)	2	kV

Note 1: Stresses beyond those listed under “absolute maximum ratings” may cause permanent damage to the device. Under “recommended operating conditions” the device operation is assured, but some particular parameter may not be achieved. The electrical characteristics table defines the operation range of the device, the electrical characteristics is assured on DC and AC voltage by test program. For the parameters without minimum and maximum value in the EC table, the typical value defines the operation range, the accuracy is not guaranteed by spec.

Note 2: The maximum power dissipation decrease if temperature rise, it is decided by T_{JMAX}, θ_{JA}, and environment temperature (T_A). The maximum power dissipation is the lower one between P_{DMAX} = (T_{JMAX} - T_A)/θ_{JA} and the number listed in the maximum table.

Note 3: Human Body mode, 100pF capacitor discharge on 1.5kΩ resistor

Recommended Operation Conditions

Symbol	Parameter	Range	Unit
P _{OUT1}	Output power (input voltage 230V±15%)	<7	W
P _{OUT2}	Output power (input voltage 85V~265V)	<5	W
F _{OP}	System operating frequency	65~70	kHz



晶丰明源半导体

BP3122B

High Precision PSR Constant Current LED Driver

Electrical Characteristics (Notes 4, 5) (Unless otherwise specified, $V_{CC}=14V$ and $T_A=25^\circ C$)

Symbol	Parameter	Conditions	Min.	Typ.	Max.	Units
Supply Voltage Section						
V_{CC_Clamp}	V_{CC} clamp voltage	1mA		17	19	V
V_{CC_ON}	Turn on threshold voltage	V_{CC} rising		13.8		V
V_{CC_UVLO}	Turn off threshold voltage	V_{CC} falling		9		V
I_{ST}	V_{CC} startup current	$V_{CC}=V_{CC_ON}-1V$		50	100	μA
I_{OP}	V_{CC} operating current	$F_{OP}=70kHz$		120	200	μA
Current Sense Section						
V_{CS_TH}	Threshold voltage for peak current limit		350	365	380	mV
T_{LEB}	Leading edge blanking time for current sense			500		ns
T_{DELAY}	Switch off delay time			200		ns
Switching Frequency						
F_{MIN}	Minimum working frequency			5		kHz
F_{OVP}	LED open circuit protection switching frequency			90		kHz
Maximum Duty Cycle						
D_{MAX}	Maximum duty cycle			42		%
MOSFET Section						
R_{DS_ON}	Static drain-source on-resistance	$V_{GS}=14V/I_{DS}=0.5A$		14		Ω
BV_{DSS}	Drain-source breakdown voltage	$V_{GS}=0V/I_{DS}=250\mu A$	650			V
I_{DSS}	Drain-source leakage current	$V_{GS}=0V/V_{DS}=650V$			10	μA
Over Temperature Protection						
T_{SD}	Thermal shutdown threshold			150		$^\circ C$
T_{SD_HYS}	Thermal shutdown hysteresis			25		$^\circ C$

Note 4: production testing of the chip is performed at $25^\circ C$.

Note 5: the maximum and minimum parameters specified are guaranteed by test, the typical value are guaranteed by design, characterization and statistical analysis



The BP3122B integrates a 650V power N-MOSFET. It can minimize the external component count and reduce the BOM cost and PCB size.

The BP3122B uses SOP-8 package. The recommended system output power is below 5W in universal input (85Vac~265Vac) application.

Operating Switching Frequency

The BP3122B is designed to work in discontinuous conduction mode and no external loop compensation component is required while maintaining stability. The maximum duty cycle is limited to 42%. The maximum switching frequency at normal operation is suggested to set around 65kHz~70kHz. If the maximum frequency is set too high, it will affect the number of maximum series LED lamps. If set too low, the LED open circuit voltage will be too high.

The maximum and minimum switching frequency is limited in BP3122B to ensure the stability of system.

The switching frequency can be set by the formula:

$$f = \frac{N_p^2 \times V_{LED}}{8 \times N_s^2 \times L_p \times I_{LED}}$$

Where, L_p is the primary winding inductance of transformer.

Protection Function

The BP3122B has integrated rich protection functions, LED open/short protection, CS resistor short circuit protection, V_{CC} under voltage protection, over temperature protection, and so on. When the LED is open circuit, it will trigger over-voltage protection logic and latch, the system stops switching immediately.

When the LED short circuit is detected, the system works at low frequency ($F_{op}=5kHz$), so the power consumption is low. At some catastrophic fault condition, such as shorted CS resistor or flyback transformer saturation, the internal fast fault detection circuit will trigger and latch, the system stops switching immediately.

After the system enters into fault latch condition, the V_{CC} voltage will fall until it reaches UVLO threshold. Then the system will re-start again. If the fault condition is removed, the system will recover to normal operation.

The thermal shutdown circuitry in the BP3122B senses the die temperature after start up, and the thermal protection threshold is set to 150°C with a 25°C hysteresis. When the temperature on die of BP3122B rises and reaches the threshold, the power MOSFET will be shut down immediately and maintained switch off until the temperature on die falls 25 °C from thermal protection trigger point.

PCB Layout

The following rules should be followed in BP3122B PCB layout:

Bypass Capacitor

The bypass capacitor on V_{CC} should be as close as possible to the V_{CC} pin and GND pin.

Ground Path

The power ground path for current sense should be short, and the power ground path should be separated from small signal ground path before the negative of the bulk capacitor.

The Area of Power Loop

The area of main current loop should be as small as possible to reduce EMI radiation, such as the primary current loop, the snubber circuit and the secondary rectifying loop.

NC Pin

The NC pin must be left floating to satisfy the requirement of creepage distance.

Drain pin

To increase the copper area of drain for thermal consideration.

Physical Dimensions

