

Description

The BP3166A is a high precision primary-side feedback and regulation controller for LED lighting, it operates in constant current control mode and is designed to work in inductor current discontinuous conduction mode and especially suitable for flyback convertor under universal input.

The BP3166A integrates a 650V power MOSFET, with patent pending MOSFET driving technique. It doesn't need the auxiliary winding for VCC supply. It can achieve excellent constant current performance with very few external components, so the system cost and size are minimized.

The BP3166A offers rich protections to improve the system reliability, including LED short circuit protection, thermal regulation function.

Features

- No VCC capacitor and no starting resistance
- Integrated HV JFET for Power Supply
- No Auxiliary winding for sensing and supplying
- Universal input voltage
- $\pm 5\%$ LED Output Current Accuracy
- LED Short Protection
- LED Open Protection
- Thermal regulation function
- Package: SOP7

Applications

- LED Bulb
- LED Candle Light
- Other LED Lighting

Typical Application

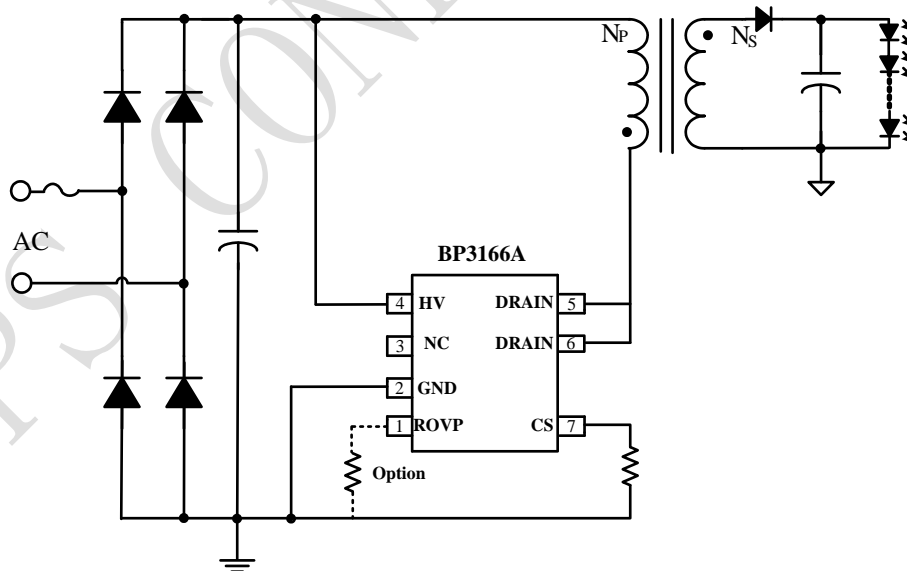

Figure 1. Typical application circuit for BP3166A

Ordering Information

Part Number	Package	Operating Temperature	Packing Method	Marking
BP3166A	SOP7	-40°C to 105°C	Tape 4,000 Piece/Reel	BP3166A XXXXXX FGXXWWX

Pin Configuration and Marking Information

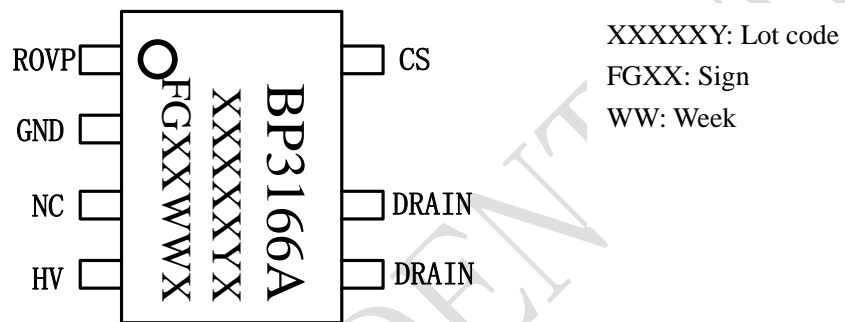

Figure 2. Pin configuration

Pin Definition

Pin Number	Name	Description
1	ROVP	Over Voltage Protection Setting Pin. Connect a resistor to GND
2	GND	Ground
3	NC	No connection, must be floated
4	HV	Internal high voltage JEFT
5, 6	DRAIN	Internal high voltage MOSFET Drain
7	CS	Current Sense Pin. Connect a sense resistor between this pin and GND.