

Description

The BP3216E is a high efficiency TRIAC dimmable LED driver. The device operates in critical conduction mode and is suitable for buck, buck-boost or fly-back LED lighting.

The BP3216E integrates a 550V power MOSFET. It utilizes patent pending MOSFET driving technique and current sensing method. The operating current of the IC is very low. With very few external components count, it can achieve excellent constant current performance, so the system cost and size are greatly reduced.

The BP3216E offers rich protection functions to improve the system reliability, including LED open circuit protection, LED short circuit protection, VCC under voltage protection, CS resistor short circuit protection and thermal regulation function.

The BP3216E is available in a SOP-8 Package.

Features

- TRIAC dimmable
- Internal 550V Power MOSFET
- Critical Conduction Mode Operation
- Ultra Low Operating Current
- $\pm 5\%$ LED Output Current Accuracy
- LED Open Protection
- LED Short Protection
- Current Sensing Resistor Short Protection
- VCC Under Voltage Protection
- Thermal Regulation Function
- Available in SOP-8 Package

Applications

- LED Candle Light
- LED Bulb
- Other LED Lighting

Typical Application

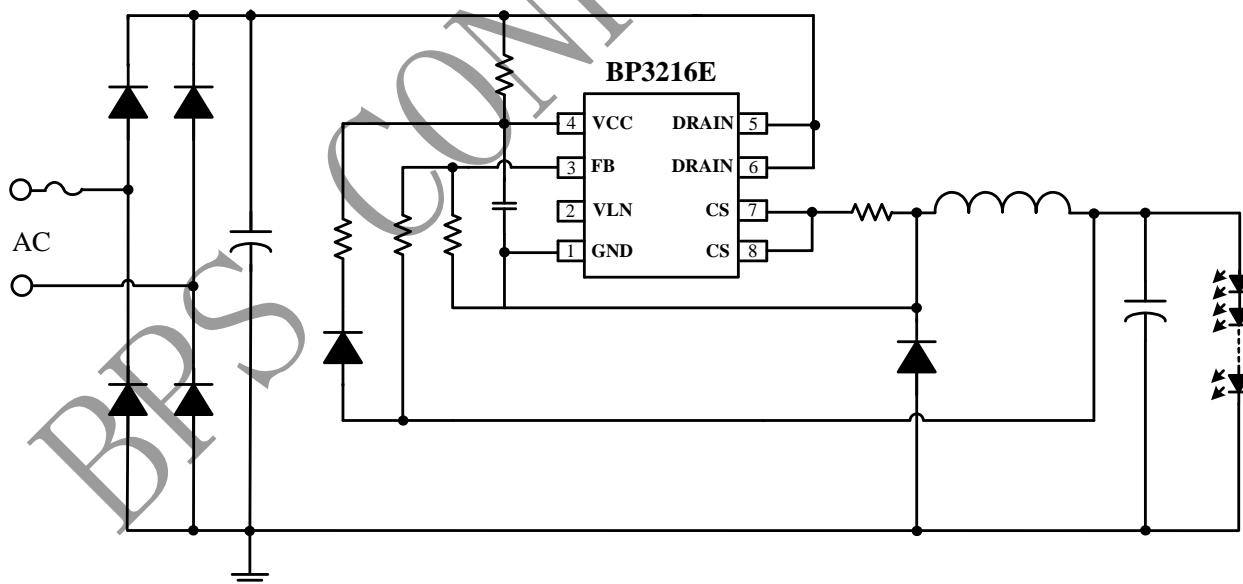

Figure 1. Typical application circuit for BP3216E (Buck)

Ordering Information

Part Number	Package	Operating Temperature	Packing Method	Marking
BP3216E	SOP8	-40 °C to 105 °C	Tape 4,000 Piece/Reel	BP3216 XXXXXY WWXYE

Pin Configuration and Marking Information

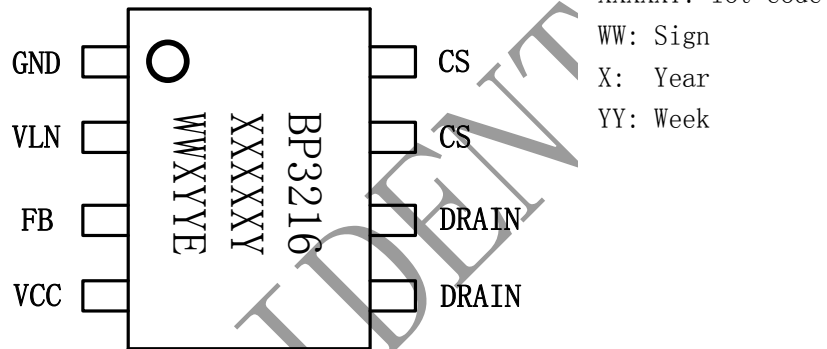

Figure 2. Pin configuration

Pin Definition

Pin No.	Name	Description
1	GND	Ground
2	VLN	Line Voltage Detecting Pin
3	FB	Over Voltage Protection Detecting Pin.
4	VCC	Power Supply Pin
5, 6	DRAIN	Internal HV Power MOSFET Drain.
7, 8	CS	Current Sense Pin. Connect a sensing resistor between CS and GND pin.

Absolute Maximum Ratings (note 1)

Symbol	Parameters	Range	Units
ICC_MAX	VCC pin maximum sink current	10	mA
DRAIN	Internal HV MOSFET drain to source voltage	-0.3~550	V
CS	Current sense pin input voltage	-0.3~6	V
FB	Over voltage protection detecting pin voltage	-0.3~6	V
VLN	Line voltage detecting pin voltage	-0.3~6	V
P_DMAX	Power dissipation (note 2)	0.45	W
θ_{JA}	Thermal resistance (Junction to Ambient)	145	°C/W
T _J	Operating junction temperature	-40 to 150	°C
T _{STG}	Storage temperature range	-55 to 150	°C
	ESD (note 3)	2	kV

Note 1: Stresses beyond those listed under “absolute maximum ratings” may cause permanent damage to the device. Under “recommended operating conditions” the device operation is assured, but some particular parameter may not be achieved. The electrical characteristics table defines the operation range of the device, the electrical characteristics is assured on DC and AC voltage by test program. For the parameters without minimum and maximum value in the EC table, the typical value defines the operation range, the accuracy is not guaranteed by spec.

Note 2: The maximum power dissipation decrease if temperature rise, it is decided by T_{JMAX} , θ_{JA} , and environment temperature (T_A). The maximum power dissipation is the lower one between $P_{DMAX} = (T_{JMAX} - T_A) / \theta_{JA}$ and the number listed in the maximum table.

Note 3: Human Body mode, 100pF capacitor discharge on 1.5kΩ resistor



晶丰明源半导体

High Efficiency TRIAC dimmable LED Driver

BP3216E

Electrical Characteristics (Notes 4, 5) (Unless otherwise specified, $V_{CC}=15V$ and $T_A=25^\circ C$)

Symbol	Parameter	Conditions	Min	Typ	Max	Units
Supply Voltage Section						
V_{CC_CLAMP}	V_{CC} Clamp Voltage	1mA		18.8		V
V_{CC_ON}	V_{CC} Turn On Threshold	V_{CC} Rising		14		V
V_{CC_UVLO}	V_{CC} Turn off Threshold	V_{CC} Falling		8.8		V
I_{ST}	V_{CC} Startup Current	$V_{CC}=V_{CC_ON}-1V$		120	180	uA
I_{OP}	V_{CC} Operating Current	$F_{OP}=70kHz$		150	250	uA
Current Sense Section						
V_{CS_TH}	Threshold Voltage for Peak Current Limit		380	400	420	mV
V_{CS_SHORT}	Threshold Voltage for Peak Current Limit When Output Short	Output Short		200		mV
T_{LEB}	Leading Edge Blanking Time for Current Sense			350		ns
T_{DELAY}	Switch Off Delay Time			200		ns
V_{VLN_TH}	Line Voltage Feed Forward Threshold			3		V
Internal Time Control Section						
T_{OFF_MIN}	Minimum OFF Time			2.5		us
T_{OFF_MAX}	Maximum OFF Time			250		us
T_{ON_MAX}	Maximum On Time			9.5		us
Over Voltage Protection Section						
V_{FB_OVP}	FB Over Voltage Protection Threshold			1		V
MOSFET Section						
R_{DS_ON}	Static Drain-source On-resistance	$V_{GS}=15V/I_{DS}=0.5A$		6		Ω
BV_{DSS}	Drain-Source Breakdown Voltage	$V_{GS}=0V/I_{DS}=250uA$	550			V
I_{DSS}	Power MOSFET Drain Leakage Current	$V_{GS}=0V/V_{DS}=550V$			1	uA
过热调节						
T_{REG}	Thermal Regulation Temperature			150		$^\circ C$

Note 4: production testing of the chip is performed at 25°C.

Note 5: the maximum and minimum parameters specified are guaranteed by test, the typical value are guaranteed by design, characterization and statistical analysis

Internal Block Diagram

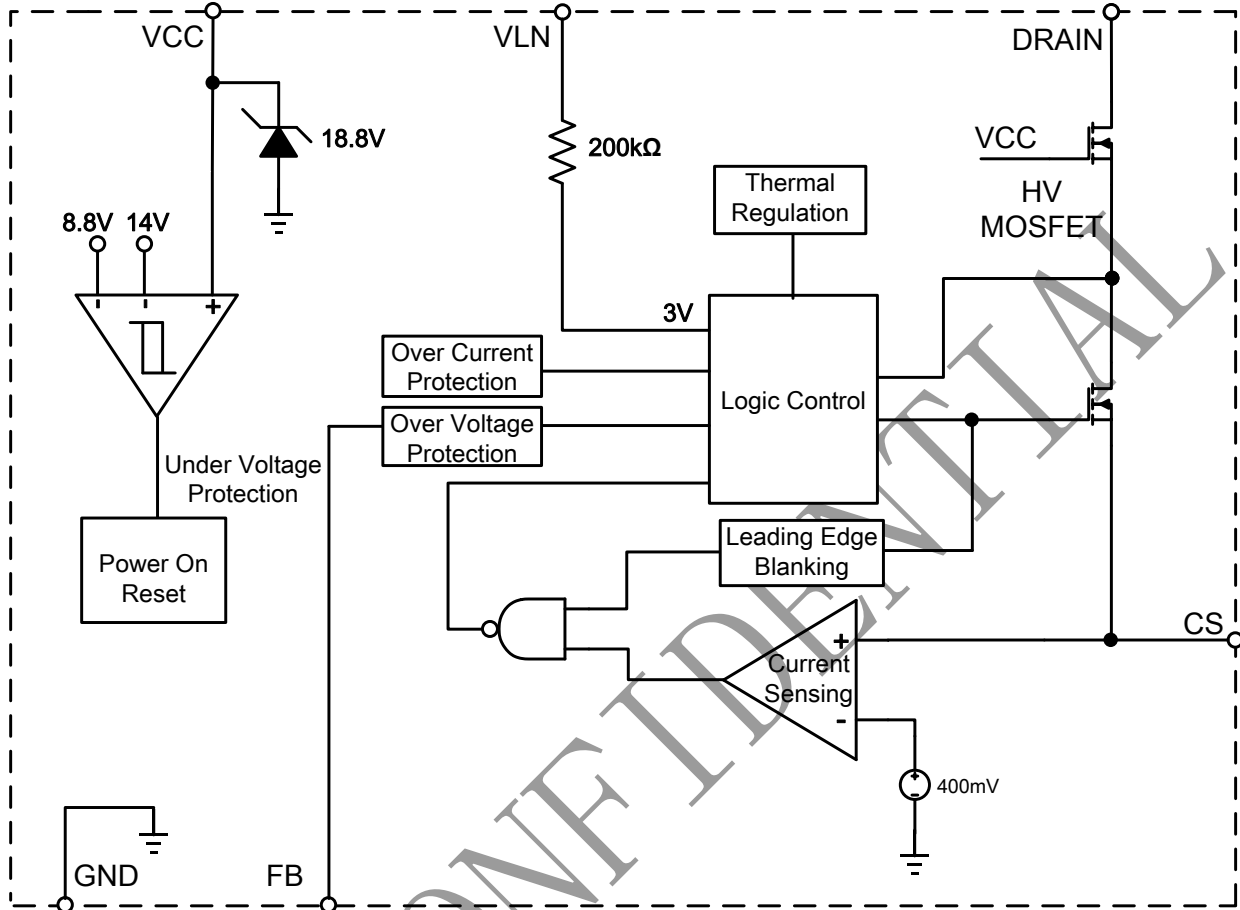

Figure 3. BP3216E Internal Block Diagram

Application Information

The BP3216E is a high efficiency TRIAC dimmable LED driver IC, specially designed for Buck, Buck-boost or Fly-back LED lighting. The BP3216E integrates a 550V power MOSFET. Utilizing patent pending MOSFET source driving technique, it can achieve excellent constant current performance with very few external components count, so the system cost and size are greatly reduced.

Start Up

After system powered up, the VCC pin capacitor is charged up by the start up resistor. When the VCC pin voltage reaches the turn on threshold, the internal circuits start operating. The BP3216E integrates an 18.8V zener diode to clamp the VCC voltage. After

the output voltage is established, VCC is supplied by the output voltage.

Constant Current Control

Cycle by Cycle current sense is adopted in BP3216E, the CS pin is connected to the current sense comparator, and the voltage on CS pin is compared with the internal 400mV reference voltage. The MOSFET will be switched off when the voltage on CS pin reaches the threshold.

The peak inductor current is given by:

$$I_{PK} = \frac{400}{R_{CS}} \text{ (mA)}$$

Where, R_{CS} is the current sense resistor value.

The CS comparator includes a 350ns leading edge blanking time.

The VLN pin detects the TRIAC dimmer conducting angle to adjust the LED driver output current. The application circuit of the VLN pin is shown in Figure 4. When the VLN pin voltage is higher than 3V, the threshold for peak current limit V_{CS_TH} decreases linearly as shown in Figure 5. When the VLN pin is not used, it can be grounded or floated.

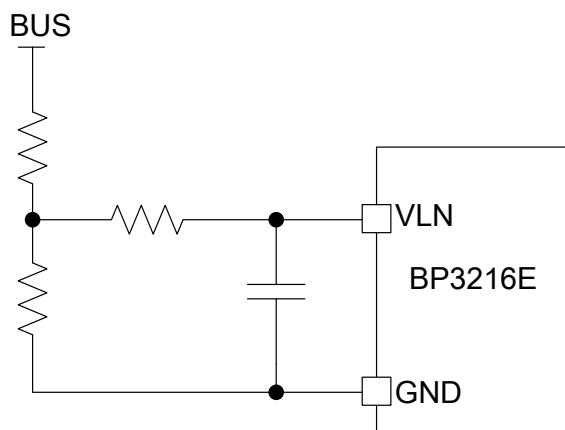

Figure 4. VLN pin application circuit

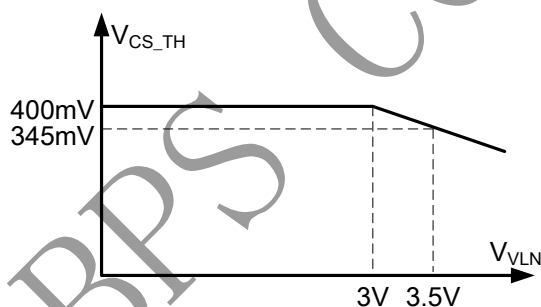

Figure 5. Relationship of VLN voltage and V_{CS_TH}

Inductor Selection

The BP3216E works under inductor current critical conduction mode. When the power MOFET is

switched on, the current in the inductor rises up from zero, the on time of the MOSFET can be calculated by the equation:

$$t_{on} = \frac{L \times I_{PK}}{V_{IN} - V_{LED}}$$

Where,

L is the inductance value.

V_{IN} is the DC bus voltage after the rectifier bridge.

V_{LED} is the voltage on the LED.

The maximum on time of the MOSFET is set to 10us internally.

After the power MOSFET is switched off, the current in the inductor decreases. When the inductor current reaches zero, the power MOSFET is turned on again by IC internal logic. The off time of the MOSFET is given by:

$$t_{off} = \frac{L \times I_{PK}}{V_{LED}}$$

The inductance can be calculated by the equation:

$$L = \frac{V_{LED} \times (V_{IN} - V_{LED})}{f \times I_{PK} \times V_{IN}}$$

Where, f is the maximum system switching frequency, which is proportional to the input voltage. So the minimum switching frequency is set at lowest input voltage, and the maximum switching frequency is set at highest input voltage.

Over Voltage Protection

The FB pin is used to detection the output voltage for over voltage protection (OVP). The FB pin threshold is 1V.

The resistor divider of the FB pin can be set as:



晶 丰 明 源 半 导 体

BP3216E

High Efficiency TRIAC dimmable LED Driver

$$\frac{R_{FBL}}{R_{FBL} + R_{FBH}} = \frac{1}{V_{OVP}}$$

Where,

R_{FBL} is the lower resistor of the resistor divider
 R_{FBH} is the higher resistor of the resistor divider
 V_{OVP} is the over voltage protection set value.

For maximizing the system efficiency, the lower resistor is recommended to be around 5K Ω .

Protection Function

The BP3216E offers rich protection functions to improve the system reliability, including LED open/short protection, CS resistor short protection, V_{CC} under voltage protection, thermal regulation.

When the LED is open circuit, the system will trigger the over voltage protection and stop switching.

When the LED short circuit is detected, the system works at low frequency (4kHz), and the CS pin turn off threshold is reduced to 200mV. So the system power consumption is very low. At some catastrophic fault condition, such as CS resistor shorted or inductor saturated, the internal fast fault detection circuit will be triggered, the system stops switching immediately.

After the system enters into fault condition, the V_{CC} voltage will decrease until it reaches the UVLO threshold, then the system will re-start again. If the fault condition is removed, the system will recover to normal operation.

Thermal Regulation

The BP3216E integrates thermal regulation function. When the system is over temperature, the output current is gradually reduced; the output power and thermal dissipation are also reduced. The system temperature is regulated and the system reliability is improved. The thermal regulation temperature is set

to 150°C internally.

PCB Layout

The following rules should be followed in BP3216E PCB layout:

Bypass Capacitor

The bypass capacitor on V_{CC} pin should be as close as possible to the V_{CC} Pin and GND pin.

FB Pin

The feedback resistor divider should be as close as possible to the FB pin, and the trace must keep away from dynamic node of the inductor and Drain pin trace, otherwise the FB pin OVP function might have risk to be mis-triggered by the system noise.

VLN Pin

The VLN pin resistor divider and capacitor should be as close as possible to the VLN pin, and the VLN node should be away from the high voltage switching nodes.

Ground Path

The power ground path for current sense resistor should be short and wide, and it should be as close as possible to the IC GND pin. The IC signal ground for FB resistors should be connected to the IC GND pin with short traces and should be away from the power ground path.

The Area of Power Loop

The area of main current loop should be as small as possible to reduce EMI radiation, such as the power MOSFET, the output diode and the bus capacitor loop.

DRAIN Pin

To increase the copper area of DRAIN pin for better thermal dissipation. However, too large copper area may compromise the EMI performance.

Physical Dimensions

