

Description

The BP3309 is a high precision primary-side regulation isolated flyback controller with single-stage Active PFC, specially designed for offline constant current LED lighting. The controller with on-chip PFC circuit operates in critical conduction mode to achieve high power factor and reduce the power MOSFET switching loss. Using proprietary current sensing scheme, the controller can precisely control the LED current without secondary side sense and feedback circuit including opto-coupler. It uses source driver architecture and patent pending internal charging circuit for low primary side switching loss, ultra fast V_{CC} startup and LED turn on.

The BP3309 uses patent compensation method to achieve excellent line regulation, and it still can be tuned externally for flexibility. The controller also has outstanding load regulation for driving wide range of LED numbers.

The BP3309 offers rich protection functions to improve the system reliability, including LED short circuit protection, LED open circuit protection, V_{CC} over voltage protection, V_{CC} under voltage protection, CS resistor short circuit protection, CS resistor open circuit protection, cycle-by-cycle current limit and die over-temperature protection. All the protection features are auto-recovery.

Features

- Single-Stage Active PFC for High Power Factor and Low THD
- Primary Side Control Constant Current Operation, No Opto-Coupler required
- Ultra Fast LED Turn On(<200ms @85Vac)
- $\pm 3\%$ LED Current Accuracy
- Excellent Line and Load Regulation
- Critical Conduction Mode Operation
- Source Driver Structure for Improved Efficiency
- Ultra-Low (20uA) Startup Current
- Ultra-Low (600uA) Operating Current
- High Resistance Feedback Resistor for Improved Efficiency
- LED Short and Open Circuit Protection
- CS Resistor Short and Open Circuit Protection
- Transformer Saturation Protection
- Cycle-by-Cycle Current Limit
- V_{CC} Over-voltage and Under-voltage Protection
- Over Temperature Protection
- Auto Recovery
- Available in SOP-8 package

Applications

- E27/ GU10 LED Bulb, Spot Light
- PAR30, PAR38 LED Lamp
- T8/T10 LED String
- Other LED Lighting

Typical Application

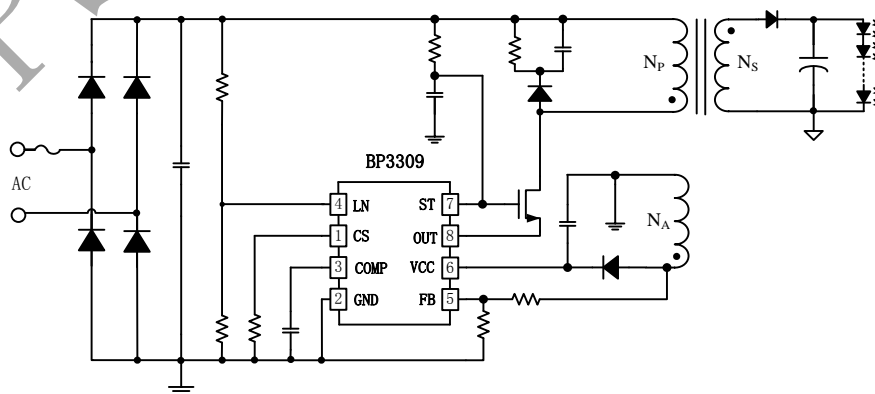

Figure 1. Typical application circuit for BP3309

Ordering Information

Part Number	Package	Operating Temperature	Package Method	Marking
BP3309	SOP8	-40°C to 105°C	Tape 2,500 Piece/Roll	BP3309 XXXXXX YYY

Pin Configuration and Marking Information

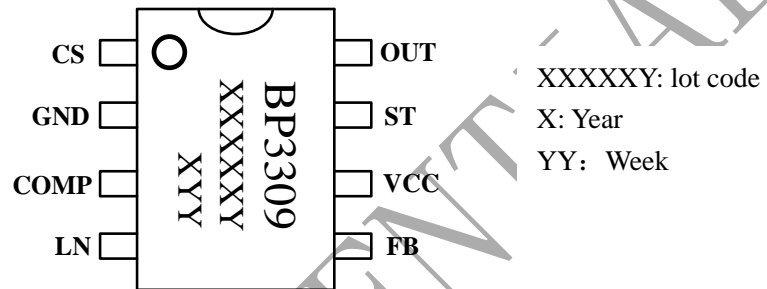

Figure 2. Pin configuration

Pin Definition

Pin No.	Name	Description
1	CS	Current Sense pin. This pin connects a resistor to GND to sense the transformer primary side current.
2	GND	Ground.
3	COMP	Loop Compensation Node. This pin connects a capacitor to GND for stabilization the control loop, achieve accurate LED current, high Power Factor and low THD.
4	LN	Line Voltage Sense Input pin. This pin connects to the middle of resistor divider from the rectified line voltage.
5	FB	Feedback Voltage Input pin. This pin detects the output information through the auxiliary winding. It is also used for line regulation compensation.
6	VCC	Power Supply pin. Connect a bypass cap from this pin to GND.
7	ST	Startup Voltage Generator pin. Connect a bypass cap from this pin to GND. This pin is also used to bias external power MOSFET gate through a resistor.
8	OUT	Internal Power MOSFET Drain. Connect to external high voltage power MOSFET source.

Absolute Maximum Ratings (note1)

Symbol	Parameters	Range	Units
V _{CC}	VCC pin input voltage	-0.3~22	V
CS	Current sense pin input voltage	-0.3~6	V
COMP	Compensation pin input voltage	-0.3~6	V
LN	Line voltage sense pin input voltage	-0.3~6	V
FB	Feedback pin input voltage	-0.3~6	V
I _{ST_MAX}	ST pin maximum sink current	5	mA
OUT	Internal MOSFET Drain voltage	-0.3~18	V
I _{OUT}	Internal MOSFET maximum current	3	A
P _{DMAX}	Power dissipation (note2)	0.45	W
θ _{JA}	Thermal resistance (Junction to Ambient)	145	°C/W
T _J	Operating junction temperature	-40 to 150	°C
T _{STG}	Storage temperature range	-55 to 150	°C
	ESD (note3)	2	KV

Note 1: Stresses beyond those listed under “absolute maximum ratings” may cause permanent damage to the device. Under “recommended operating conditions” the device operation is assured, but some particular parameter may not be achieved. The electrical characteristics table defines the operation range of the device, the electrical characteristics is assured on DC and AC voltage by test program. For the parameters without minimum and maximum value in the EC table, the typical value defines the operation range, the accuracy is not guaranteed by spec.

Note 2: The maximum power dissipation decrease if temperature rise, it is decided by T_{JMAX}, θ_{JA}, and environment temperature (T_A). The maximum power dissipation is the lower one between P_{DMAX} = (T_{JMAX} - T_A)/θ_{JA} and the number listed in the maximum table.

Note 3: Human Body mode, 100pF capacitor discharge on 1.5KΩ resistor

Recommended Operation Conditions

Symbol	Parameter	Range	Unit
V _{CC}	Power supply voltage	11.5~17.5	V

Recommended Key Component Value

Symbol	Parameter	Value	Unit
Cap_V _{CC}	V _{CC} capacitor	2.2	uF
Cap_ST	Start up capacitor	470	nF

Electrical Characteristics (Notes 4,5) (Unless otherwise specified, $V_{CC}=14V$ and $T_A=25^\circ C$)

Symbol	Parameter	Conditions	Min	Typ	Max	Units
Startup Voltage Section						
V_{ST_ON}	V_{ST} Startup Voltage	1mA, $V_{CC}=10V$	16	17	18	V
V_{ST_HYS}	V_{ST} Hysteresis Voltage	$V_{CC}=14V$		2		V
I_{ST_ON}	ST Startup Current	$V_{CC}=10V$		20	35	μA
I_{ST_OP}	ST Operating Current	$V_{CC}=14V$		35	60	μA
Supply Voltage Section						
V_{CC_ON}	V_{CC} Startup Voltage	V_{CC} Rising	10	11	12	V
V_{CC_UVLO}	V_{CC} Turn Off Threshold	V_{CC} Falling	5.2	5.8	6.5	V
V_{CC_HOLD}	V_{CC} Hold Voltage	V_{CC} Falling	7	7.5	8	V
I_{CC_UVLO}	V_{CC} Shutdown Current	V_{CC} Rising, $V_{CC}=10V$		40	70	μA
I_Q	V_{CC} Quiescent Current	No Switching, $V_{CC}=14V$		320	600	μA
I_{CC}	V_{CC} Operating Current	$F_{OP}=60kHz$		600		μA
V_{CC_OVP}	V_{CC} Overvoltage Protection Threshold			20		V
Feedback Section						
V_{FB_FALL}	FB Falling Edge Threshold Voltage	FB Falling		0.4		V
V_{FB_HYS}	FB Hysteresis Voltage	FB Rising		0.6		V
V_{FB_OVP}	Output Open FB pin Detect Voltage			5.5		V
T_{OFF_MIN}	Minimum OFF time	After Turn OFF		4.0		μs
T_{OFF_MAX}	Maximum OFF time	After Turn OFF		150		μs
Current Sense Section						
T_{LEB_CS}	Leading Edge Blanking Time for Current Sense	After Turn ON		350		ns
T_{DELAY}	Switch off Delay Time			180		ns

Symbol	Parameter	Conditions	Min.	Typ.	Max.	Units
Compensation Section						
V_{REF}	Internal Reference Voltage		0.294	0.300	0.306	V
V_{COMP_LO}	COMP Low Clamp Voltage			1.5		V
V_{COMP}	COMP Linear Operating Voltage Range		1.5		3.5	V
V_{COMP_OVP}	Output Short COMP pin Detect Voltage			4.5		V
LN Section						
V_{LN}	LN Linear Operating Voltage Range		0		2.5	V
MOSFET Section						
R_{DS_ON}	Internal MOSFET ON Resistance	$V_{CC} = 14V$		500		m Ω
Over Temperature Protection						
T_{SD}	Thermal Shutdown Threshold	Temperature Rising		150		$^{\circ}C$
T_{SD_HYS}	Thermal Shutdown Hysteresis	Temperature Falling		30		$^{\circ}C$

Note 4 : production testing of the chip is performed at 25 $^{\circ}C$.

Note 5: the maximum and minimum parameters specified are guaranteed by test, the typical value are guaranteed by design, characterization and statistical analysis

Internal Block Diagram

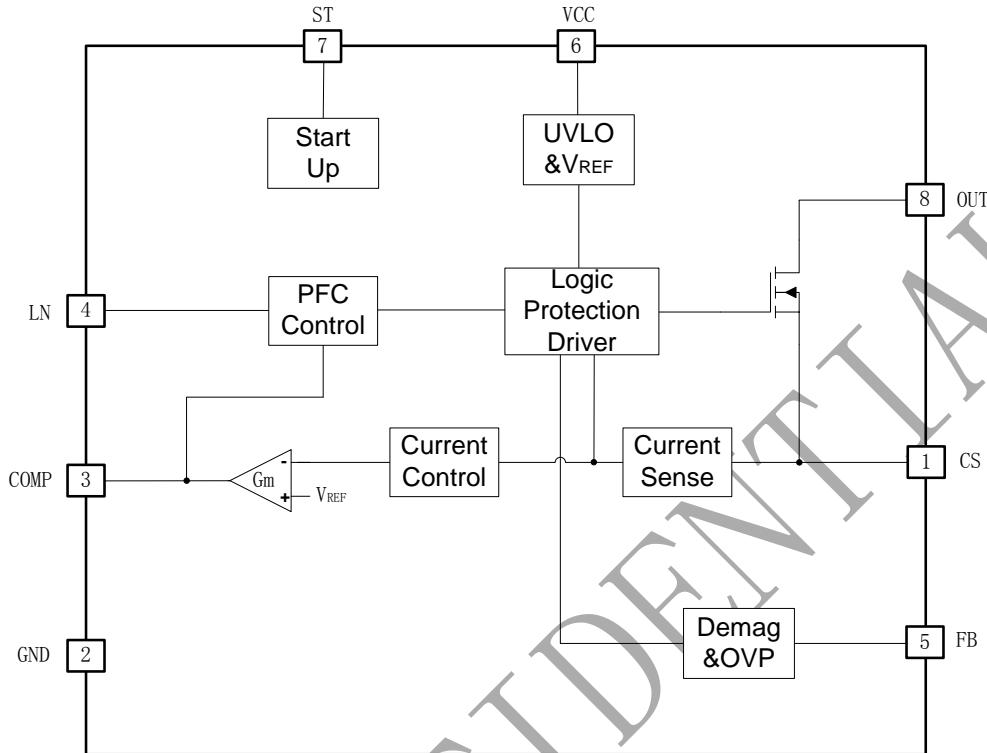

Figure 3. BP3309 Internal Block Diagram

Function Description

The BP3309 is a high precision PSR single-stage Active PFC controller for offline constant current LED lighting. By using critical conduction mode, the controller achieves high power factor, low THD and high efficiency.

Start Up

The capacitor at ST pin is charged from the rectified bus voltage through the start-up resistor when the system is powered on (the ST capacitor is recommended to 470nF), and V_{CC} voltage will follow ST pin voltage ramp (the V_{CC} capacitor is recommended to 2.2uF). The BP3309 uses source driver architecture and patent pending internal charging circuit for ultra fast V_{CC} startup, while need not compromise the system efficiency.

Once the voltage on V_{CC} reaches the start-up threshold, the BP3309 starts to switch and the

internal charging circuit turns off. Then the V_{CC} is supplied by the auxiliary winding. At the first switching cycles, the switching frequency is 7kHz and the LED current is softly rising up to avoid overshoot. The total time from power on to LED turn on is around 200ms @85Vac, even with 1MΩ startup resistor.

At normal operation, in case the LED number is very few and the auxiliary winding can't supply the V_{CC}, the internal charging circuit will turn on again to supply the V_{CC}. Then V_{CC} will stay at a voltage near 10V, and the system still can work normally. With this function, the system can work at wide range of LED numbers.

Constant Current Control

The BP3309 uses proprietary current sensing scheme, it can precisely control the LED current without secondary side sense and feedback circuit including opto-coupler.



The current in LED can be calculated by the equation:

$$I_{OUT} \approx \frac{V_{REF}}{2 \times R_{CS}} \times \frac{N_P}{N_S}$$

Where,

V_{REF} : Internal reference voltage, typical 0.3V

N_P : Primary winding turns of transformer

N_S : Secondary winding turns of transformer

Feedback Network

The BP3309 senses the output current crossing zero through the feedback network, the FB falling threshold voltage is set to 0.4V with 0.6V hysteresis. The FB pin is also used to detect output OVP, the threshold voltage is 5.5V. The ratio of FB upper resistor to lower resistor can be set as:

$$\frac{R_{FBL}}{R_{FBL} + R_{FBH}} = \frac{5.5V}{V_{OVP}} \times \frac{N_S}{N_A}$$

Where,

R_{FBL} : The lower resistor of the feedback network

R_{FBH} : The upper resistor of the feedback network

V_{OVP} : Output over voltage setting point

N_S : Secondary winding turns of transformer

N_A : Auxiliary winding turns of transformer

The FB upper resistor can be set to around 300K Ω to improve the system efficiency. It is also used for fine tuning the LED current line compensation.

Protection Function

The BP3309 has many protection functions to improve the system reliability. When the voltage on V_{CC} reaches the corresponding 20V OVP threshold, such as under open LED condition, it will trigger fault logic and latch, the system stops switching.

When the LED is shorted circuit, the system will work under 7kHz switching frequency, so the power consumption is low. At the same while, the COMP pin voltage will rise up until it reaches 4.5V. It will trigger fault logic and latch, the system stops switching. At some catastrophic fault condition, such

as shorted CS resistor or flyback transformer saturation, the internal fast fault detection circuit will trigger and the system stop switching immediately.

The over temperature protection circuitry in the BP3309 monitors the die junction temperature after start up. When the temperature rises to 150 $^{\circ}$ C, the system will stop switching and latched. The power MOSFET will be shut down immediately and maintains at switch off condition until the temperature on die falls 30 $^{\circ}$ C below the thermal protection trigger point.

After the system enters into fault latch condition, the V_{CC} voltage will fall until it reaches UVLO threshold. Then the system will re-start again. If the fault condition is removed, the system will work normally.

PCB Layout

The following guidelines should be followed in BP3309 PCB layout:

Bypass Capacitor

The bypass capacitor on ST and V_{CC} pin should be as close as possible to the respective pins.

Ground Path

The power ground path for current sense should be short, and the power ground path should be separated from small signal ground path before the negative node of the bus capacitor.

The Area of Power Loop

The area of main current loop should be as small as possible to reduce EMI radiation, such as the primary current loop, the snubber circuit and the secondary rectifying loop.

FB Pin

The feedback resistor divider should be as close as possible to the FB pin and the node must keep away from dynamic node of the transformer.

Physical Dimensions

