

Description

The BP3318 is a dimmable high precision primary-side regulation PWM controller with single stage Active PFC, specially designed for universal input offline flyback or buck-boost constant current LED driver. The controller with on-chip PFC circuit achieves high power factor and low THD. Operating in critical conduction mode, the power MOSFET switching loss is reduced and the inductor is fully utilized.

The BP3318 adopts proprietary primary side current sensing scheme. It can precisely control the LED current without secondary side sense and feedback circuits. The system size and cost are optimized, as well as the system reliability.

The BP3318 utilizes patented line and load voltage compensation method to achieve excellent line and load regulation. And the line compensation factor can also be tuned externally for flexibility.

The BP3318 offers rich protection functions to improve the system reliability, including LED open circuit protection, LED short circuit protection, VCC over voltage protection, VCC under voltage protection, CS resistor open protection and cycle by cycle current limit. All the protection functions are auto-recovery. The system reliability is further improved by the thermal regulation function. The output current is reduced when the controller is over temperature.

Typical Application

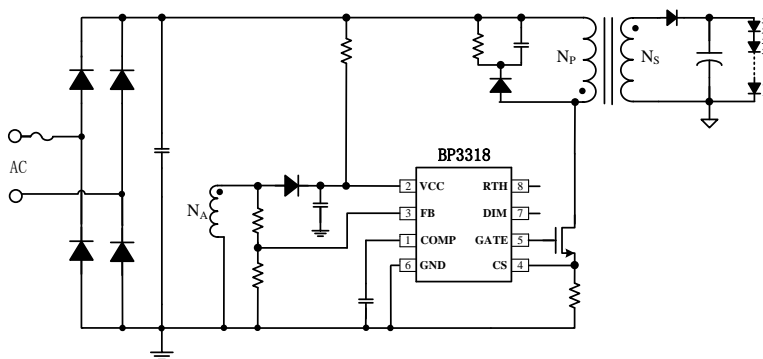

Figure 1. Typical application circuit for BP3318

Features

- Single-Stage Active PFC for High Power Factor and Low THD
- Primary Side Control Constant Current Operation, No Opto-Coupler required
- Dimmable Interface
- $\pm 3\%$ LED Current Accuracy
- Excellent Line and Load Regulation
- Critical Conduction Mode Operation
- Ultra-Low (33uA) Startup Current
- High Resistance Feedback Resistor for Improved Efficiency
- LED Open and Short Circuit Protection
- CS Resistor Open Circuit Protection
- Cycle-by-Cycle Current Limit
- VCC Over-voltage and Under-voltage Protection
- Auto Fault Recovery
- Thermal Regulation Function
- Available in Tiny SOP8 package

Applications

- E27/ GU10 LED Bulb, Spot Light
- PAR30, PAR38 LED Lamp
- T8/T10 LED String
- Other LED Lighting

Ordering Information

Part Number	Package	Operating Temperature	Packing Method	Marking
BP3318	SOP8	-40 °C to 105 °C	Tape 4,000 Piece/Reel	BP3318 XXXXXY XXY

Pin Configuration

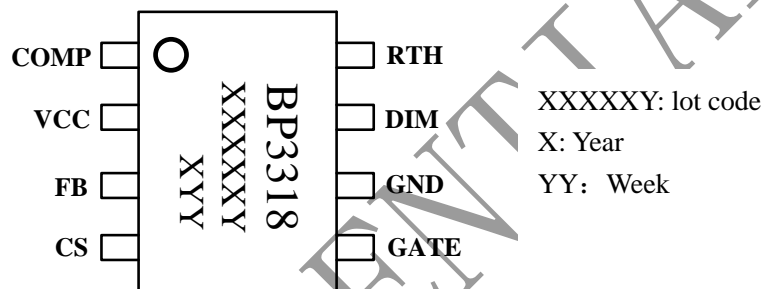

Figure 2. Pin configuration

Pin Definition

Pin No.	Name	Description
1	COMP	Loop Compensation Node. This pin connects a capacitor to GND for stabilization of the control loop, achieving accurate LED current, high Power Factor and low THD.
2	VCC	Power Supply Pin. Connect a bypass capacitor from this pin to GND
3	FB	Feedback Voltage Input Pin. This pin detects the transformer demagnetization signal and the output voltage.
4	CS	Current Sense Pin. Connect a resistor to GND to sense the power MOSFET current.
5	GATE	Gate Driver Pin. Connect this pin to the gate of external power MOSFET.
6	GND	Ground.
7	DIM	Dimming Signal Input Pin. Float when not used.
8	RTH	Thermal Regulation Set Pin. Connect a resistor to GND to set the thermal regulation point. Float when not used.

Absolute Maximum Ratings (note1)

Symbol	Parameters	Range	Units
V _{CC}	VCC pin input voltage	-0.3~25	V
I _{CC_MAX}	VCC pin maximum sink current	5	mA
COMP	Compensation pin voltage	-0.3~6	V
FB	Feedback pin input voltage	-0.3~6	V
CS	Current sense pin input voltage	-0.3~6	V
DIM	Dimming signal input pin voltage	-0.3~6	V
RTH	Thermal regulation set pin voltage	-0.3~6	V
GATE	Gate driver pin voltage	-0.3~25	V
P _{DMAX}	Power dissipation (note2)	0.45	W
θ _{JA}	Thermal resistance (Junction to Ambient)	145	°C/W
T _J	Operating junction temperature	-40 to 150	°C
T _{STG}	Storage temperature range	-55 to 150	°C
	ESD (note3)	2	kV

Note 1: Stresses beyond those listed under “absolute maximum ratings” may cause permanent damage to the device. Under “recommended operating conditions” the device operation is assured, but some particular parameter may not be achieved. The electrical characteristics table defines the operation range of the device, the electrical characteristics is assured on DC and AC voltage by test program. For the parameters without minimum and maximum value in the EC table, the typical value defines the operation range, the accuracy is not guaranteed by spec.

Note 2: The maximum power dissipation decrease if temperature rise, it is decided by T_{JMAX} , θ_{JA} , and environment temperature (T_A). The maximum power dissipation is the lower one between $P_{DMAX} = (T_{JMAX} - T_A) / \theta_{JA}$ and the number listed in the maximum table.

Note 3: Human Body mode, 100pF capacitor discharge on 1.5kΩ resistor

Recommended Operation Conditions

Symbol	Parameter	Range	Unit
V _{CC}	Power supply voltage	8.5 ~ 18	V



Electrical Characteristics (Notes 4, 5) (Unless otherwise specified, $V_{CC}=15V$ and $T_A=25\text{ }^\circ\text{C}$)

Symbol	Parameter	Conditions	Min	Typ	Max	Units
Supply Voltage Section						
V_{CC_ON}	V_{CC} Turn On Threshold	V_{CC} Rising		16.7		V
V_{CC_UVLO}	V_{CC} Turn Off Threshold	V_{CC} Falling		7.5		V
V_{CC_OVP}	V_{CC} Over Voltage Protection threshold			19		V
V_{CC_CLAMP}	V_{CC} Clamp Voltage			23		V
I_{CC_UVLO}	V_{CC} Startup Current	V_{CC} Rising $V_{CC}=V_{CC_ON}-1V$		33	50	uA
I_{CC}	V_{CC} Operating Current	$F_{OP}=10kHz$, Load=100pF		0.5	1	mA
Feedback Section						
V_{FB_FALL}	FB Falling Edge Threshold Voltage	FB Falling		0.1		V
V_{FB_HYS}	FB Hysteresis Voltage	FB Rising		0.08		V
V_{FB_OVP}	FB Over Voltage Protection Threshold			1.6		V
T_{ON_MAX}	Maximum On Time			25		us
T_{OFF_MIN}	Minimum Off Time			4.5		us
T_{OFF_MAX}	Maximum Off Time			100		us
Current Sense Section						
V_{CS_LIMIT}	CS Peak Voltage Limitation			1.0		V
T_{LBB_CS}	Leading Edge Blanking Time for Current Sense			350		ns
T_{DELAY}	Switch off Delay Time			200		ns
Compensation Section						
V_{REF}	Internal Reference Voltage		0.194	0.200	0.206	V
V_{COMP_LO}	COMP Low Clamp Voltage			1.5		V

Symbol	Parameter	Conditions	Min	Typ	Max	Units
V _{COMP}	COMP Linear Operating Voltage Range		1.5		3.5	V
V _{COMP_OVP}	COMP Protection Threshold			3.6		V
Dimming Section						
V _{DIM_ON}	Dimming On Threshold	DIM Rising		0.9		V
V _{DIM_HYS}	Dimming Off Hysteresis	DIM Falling		0.2		V
V _{DIM_MIN}	Dimming Low Saturation Voltage			1.0		V
V _{DIM_MAX}	Dimming High Saturation Voltage			3.0		V
V _{DIM_OPEN}	DIM Open Voltage			5		V
R _{DIM_PULL UP}	DIM Pull Up Resistance			600		kΩ
Driver Section						
I _{SOURCE_MAX}	GATE pin Maximum Sourcing Current			200		mA
I _{SINK_MAX}	GATE pin Maximum Sinking Current			600		mA
Thermal Regulation Section						
V _{RTH}	RTH pin Voltage			1.0		V
T _{REG}	Thermal Regulation Temperature	RTH pin Floating		150		°C

Note 4: production testing of the chip is performed at 25 °C.

Note 5: the maximum and minimum parameters specified are guaranteed by test, the typical value are guaranteed by design, characterization and statistical analysis

Internal Block Diagram

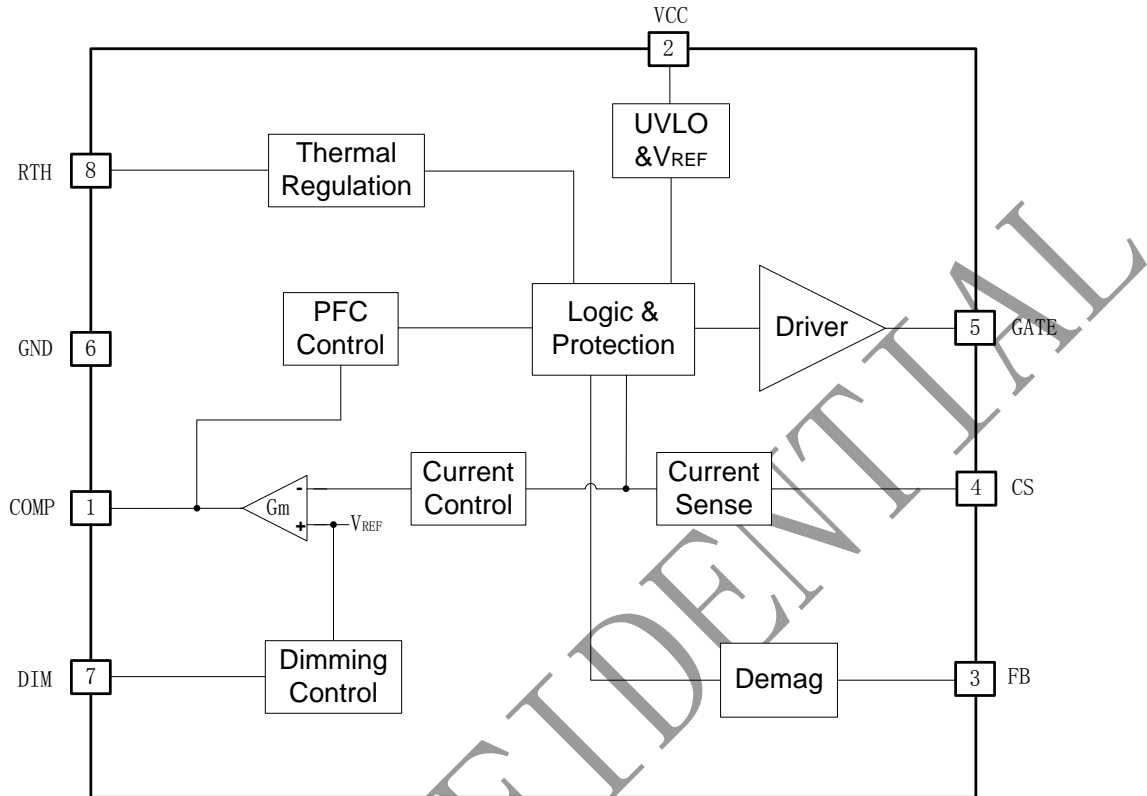

Figure 3. BP3318 Internal Block Diagram

Application Information

The BP3318 is a dimmable high precision primary-side regulation single stage Active PFC controller for constant current LED driver. Operating in critical conduction mode, the controller achieves high power factor, low THD and high efficiency.

1 Start Up

After system powered up, the VCC pin capacitor is charged up by the start up resistor. When the VCC pin voltage reaches the turn on threshold, the internal circuits start working. The COMP pin voltage is pulled up to 1.5V quickly, and then the BP3318 starts the MOSFET driver. The system works at 10kHz frequency at the beginning, the COMP voltage rises up gradually, and the transformer primary peak current also rises up. The LED current hence achieves a soft start without overshoot. After the output voltage is built up, the VCC power is supplied

by the auxiliary winding.

2 Constant Current Control

The BP3318 adopts proprietary primary side current sensing scheme. It can precisely control the LED current without secondary side sense and feedback circuit.

The current in LED can be calculated by the equation:

$$I_{OUT} \approx \frac{V_{REF}}{2 \times R_{CS}} \times \frac{N_P}{N_S}$$

Where,

V_{REF}: Internal reference voltage

N_P: Primary winding turns of transformer

N_S: Secondary winding turns of transformer

R_{CS}: The current sensing resistor value

3 Feedback Network

The BP3318 senses the output current zero crossing information through the feedback network, the FB falling threshold voltage is set to 0.1V with 0.08V hysteresis. The FB pin is also used to detect output OVP, the threshold voltage is 1.6V. The ratio of FB upper resistor to lower resistor can be set as:

$$\frac{R_{FBL}}{R_{FBL} + R_{FBH}} = \frac{1.6V}{V_{OVP_FB}} \times \frac{N_S}{N_A}$$

Where,

R_{FBL} : The lower resistor of the feedback network

R_{FBH} : The upper resistor of the feedback network

V_{OVP_FB} : Output over voltage setting point

N_S : Secondary winding turns of transformer

N_A : Auxiliary winding turns of transformer

The FB upper resistor can be set to around 330kΩ to improve the system efficiency. It is also used for fine tuning the LED current line compensation.

4 Dimming Function

The BP3318 integrates an analog dimming interface. With simple external circuits, it can be compatible with Analog dimming, PWM dimming and TRIAC dimming.

The linear range of DIM pin voltage is 1V-3V. Within this range, the output LED current is higher when DIM pin voltage is higher. When the DIM pin voltage is lower than 0.7V, the gate driver is turned off, the COMP pin voltage is pulled down to 1.5V and the output LED current is zero. When the DIM pin voltage is higher than 3V, the output LED current is 100% of the set value.

If the dimming function is not used, it is recommend to connect a 100pF capacitor from this pin to ground.

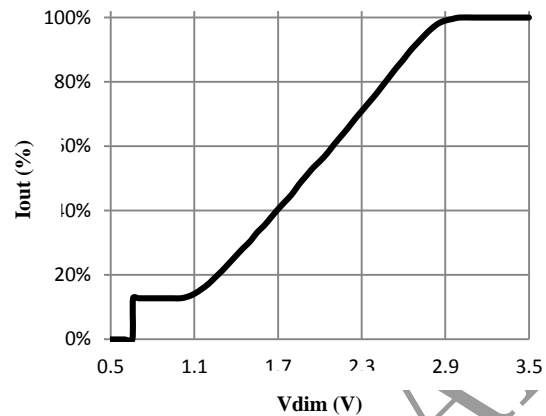

Output LED Current vs. DIM pin voltage

5 Thermal Regulation

The BP3318 integrates thermal regulation function. When the system is over temperature, the output current is gradually reduced; the output power and thermal dissipation are also reduced. The system temperature is regulated and the system reliability is improved.

The thermal regulation temperature can be set by the resistor on RTH pin. The RTH pin voltage is 1.0V. With a smaller resistance value, the thermal regulation temperature is lower.

If the RTH pin is floated, the thermal regulation temperature is to 150°C internally.

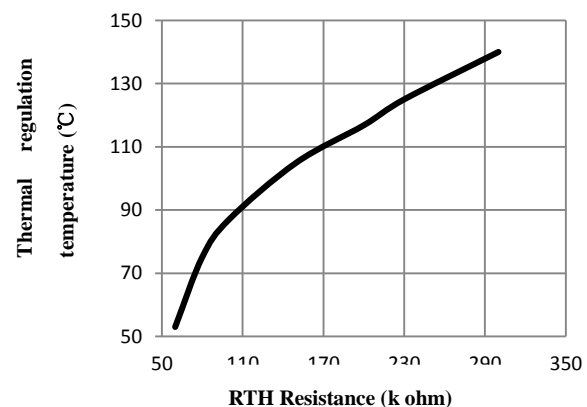

Thermal Regulation Temperature vs. RTH pin Resistance

6 Protection Functions

The BP3318 offers rich protection functions to



improve the system reliability.

When the LED is open circuit, the output voltage will gradually rise up. The V_{CC} voltage will also rise up. When V_{CC} voltage reaches the 19V OVP threshold, it will trigger fault logic and the system stops switching. At some catastrophic fault condition, if the V_{CC} voltage continues to rise, the internal clamping circuit will limit the V_{CC} voltage to 23V, which helps improving the system reliability.

When the LED is shorted circuit, the system will work under 10 kHz switching frequency. Meanwhile, the output voltage is low and the auxiliary winding cannot charge the VCC pin. So the VCC pin voltage will gradually decrease and finally reaches the UVLO threshold.

After the system enters into fault condition, the VCC voltage will decrease until it reaches UVLO threshold, then the system will re-start again. If the fault condition is removed, the system will resume normal operation.

When the output is short circuit or the transformer is saturated, the CS peak voltage will be relatively high. When CS voltage reaches the internal limitation (1V), the power MOSFET will be turned off instantaneously. This cycle by cycle current limitation can help protecting the power MOSFET, the transformer and the output rectifying diode.

7 PCB Layouts

The following guidelines should be followed in BP3318 PCB layout:

Bypass Capacitor

The bypass capacitor on VCC pin should be as close as possible to the VCC and GND pins.

Ground Path

The power ground path for current sense resistor should be short and wide, and it should be as close as possible to the IC ground (pin 2), otherwise the LED output current accuracy maybe affected. The IC

signal ground for COMP and FB components should be connected to the IC GND pin with short traces and should be away from the power ground path.

The Area of Power Loop

The area of main current loop should be as small as possible to reduce EMI radiation, such as the primary current loop, the snubber circuit and the secondary rectifying loop.

FB Pin

The feedback resistor divider should be as close as possible to the FB pin, and the trace must keeps away from dynamic node of the transformer and MOSFET DRAIN trace, otherwise the FB pin OVP function might have risk to be mis-triggered by the system noise.

Physical Dimensions

