

Description

BP5656E is a LED current ripple remover, working with TRIAC-dimmable LED driver or single-stage active PFC LED driver to remove the low frequency LED current ripple. BP5656E utilizes high-efficiency control scheme. It can automatically adapt to wide range LED voltage and current, removing the LED current ripple while keeping the MOSFET power loss as minimum as possible.

BP5656E offers multiple protections, including drain voltage OVP, LED short protection and over temperature protection.

BP5656E is available in SOP8 package.

Features

- Integrated with 500V JFET
- Internal digital loop compensation
- OVP voltage adjustable
- SCP voltage adjustable
- Low component count
- Over-temperature protection
- Available in SOP8 package

Applications

- LED Bulb
- LED panel light
- Other LED lighting

Typical Application

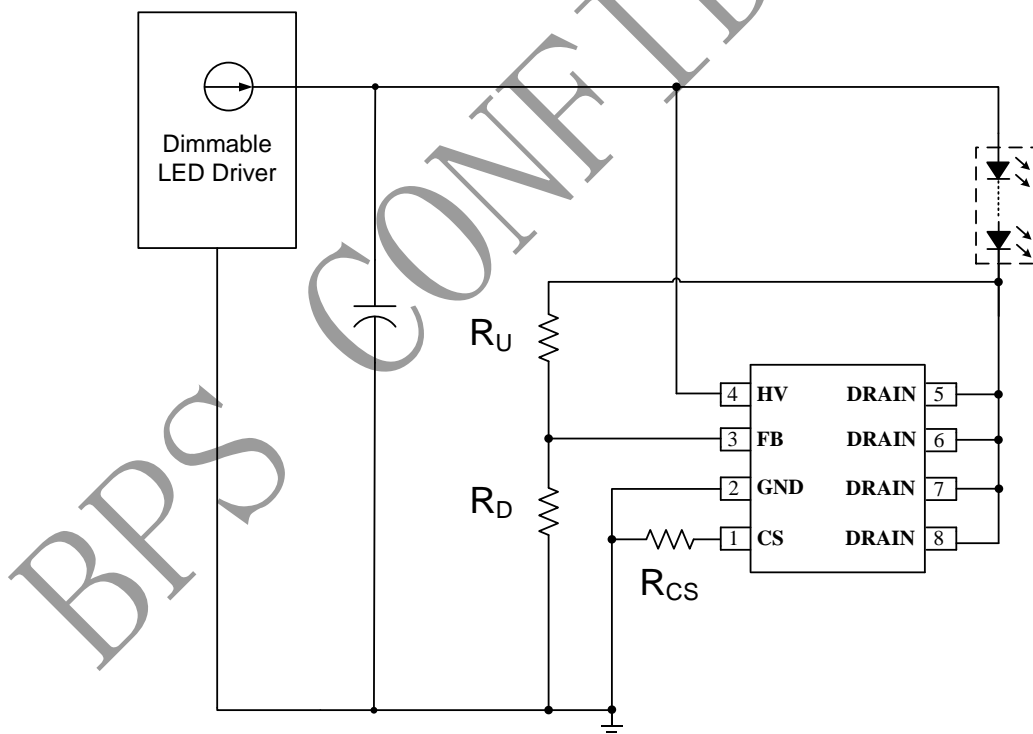

Fig.1 Typical Application of BP5656E

Ordering Information

Part Number	Package	Operating Temperature	Packing Method	Marking
BP5656E	SOP8	-40 °C to 105 °C	Tape 4,000 Piece/Reel	BP5656 LLLLCX YYMMWE

Pin Configuration and Marking Information

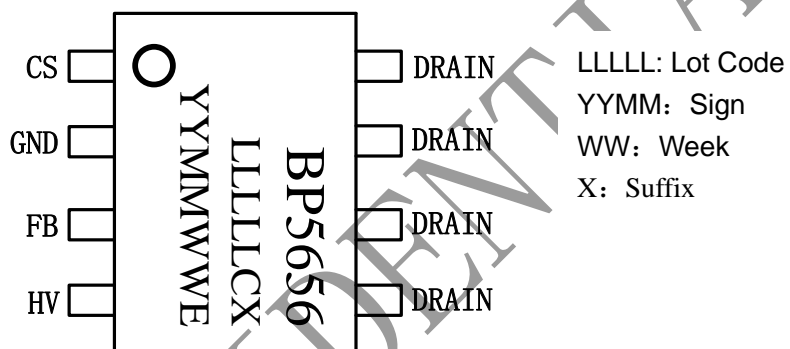

Fig.2 Pin Configuration

Pin Definition

Pin No.	Name	Description
1	CS	LED current sensing
2	GND	IC Ground
3	FB	Feedback pin of MOSFET drain voltage
4	HV	JFET for IC power supply
5, 6, 7, 8	DRAIN	MOSFET DRAIN



BP5656E

晶丰明源半导体 Current Ripple Remover for Dimmable LED Driver

Absolute Maximum Ratings (Note 1)

Symbol	Parameters	Range	Units
HV	JFET for IC power supply	-0.3~500	V
V _{DSS}	Breakdown Voltage of MOSFET	200	V
CS	LED current sensing pin	-0.3~6	V
FB	Drain voltage feedback	-0.3~6	V
P _{DMAX}	Power dissipation (note 2)	0.45	W
θ _{JA}	Thermal resistance (Junction to Ambient)	150	°C/W
T _J	Operating junction temperature	-40 to 150	°C
T _{STG}	Storage temperature range	-55 to 150	°C

Note 1: Stresses beyond those listed under “absolute maximum ratings” may cause permanent damage to the device. Under “recommended operating conditions” the device operation is assured, but some particular parameter may not be achieved. The electrical characteristics table defines the operation range of the device, the electrical characteristics is assured on DC and AC voltage by test program. For the parameters without minimum and maximum value in the EC table, the typical value defines the operation range, the accuracy is not guaranteed by spec.

Note 2: The maximum power dissipation decreases if temperature rise, it is decided by T_{JMAX} , θ_{JA} , and environment temperature (T_A). The maximum power dissipation is the lower one between $P_{DMAX} = (T_{JMAX} - T_A) / \theta_{JA}$ and the number listed in the maximum table.



BP5656E

晶丰明源半导体 Current Ripple Remover for Dimmable LED Driver

Electrical Characteristics(Notes 3, 4) (Unless otherwise specified, $V_{HV}=40\text{ V}$, $T_A=25\text{ }^\circ\text{C}$)

Symbol	Parameter	Condition	Min	Typ.	Max	Units
IC Power Supply						
V_{HV}	HV Operating Voltage		16		500	V
I_{CC}	Quiescent current	HV=40V		400	520	uA
FB Setting						
V_{FB_OVP1}	FB OVP Threshold1	CS=0.2V		2.0		V
V_{FB_OVP2}	FB OVP Threshold2	CS=0V		0.5		V
V_{FB_CLAMP}	FB Clamping Voltage			5.3		V
I_{FB_SCP}	FB SCP Threshold			160		uA
CS Limit						
V_{CS_LMT}	CS Limit			0.2		V
Internal MOSFET						
R_{DSON}	MOSFET Rdson	$V_{GS}=10\text{V}$, $I_D=1\text{A}$		500		m Ω
V_{DSS}	Maximum Voltage		200			V
Thermal Regulation						
T_{REG}	Thermal Regulation Voltage			150		$^\circ\text{C}$

Note 3: production testing of the chip is performed at 25 $^\circ\text{C}$.

Note 4: the maximum and minimum parameters specified are guaranteed by test, the typical value are guaranteed by design, characterization and statistical analysis

Internal Block Diagram

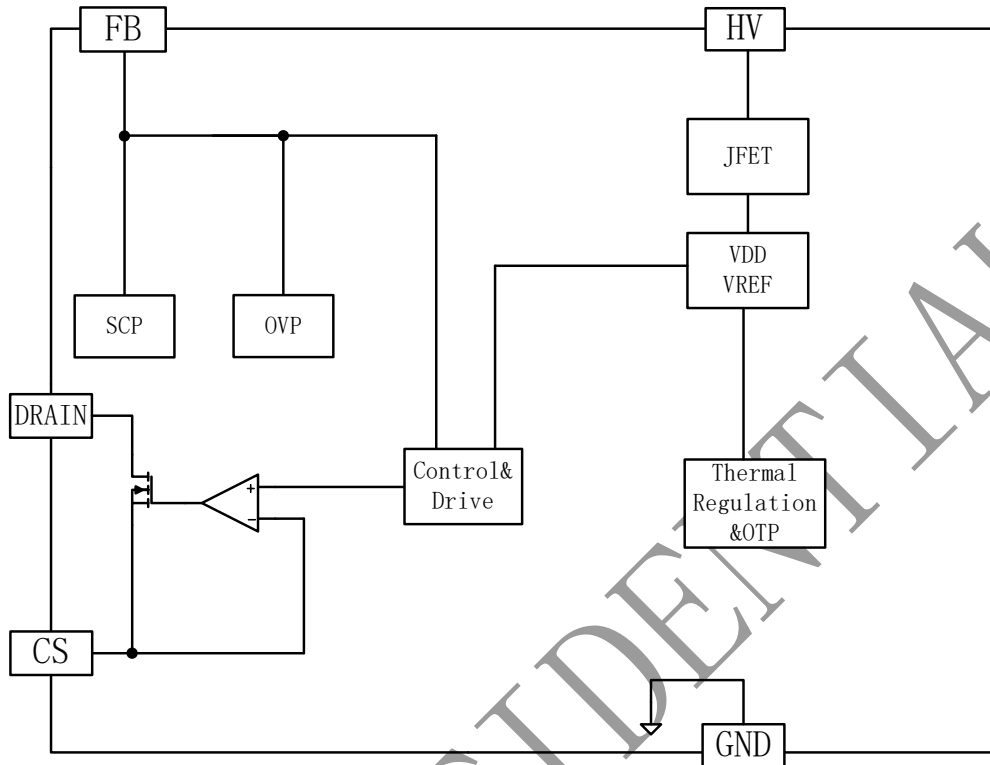

Fig. 3 BP5656E Internal Block Diagram

Application Information

BP5656E is a LED current ripple remover, working with TRIAC-dimmable LED driver or single-stage active PFC LED driver to remove the low frequency LED current ripple. BP5656E utilizes high-efficiency control scheme. It can automatically adapt to wide range LED voltage and current, removing the LED current ripple while keeping the MOSFET power loss as minimum as possible.

Start-up and IC Power Supply

VDD power supply inside BP5656E is powered by HV pin. When internal VDD voltage is charged above turn-on threshold, the BP5656E begins to work.

CS Resistance Setting

CS Resistance is set as:

$$R_{CS} \approx \frac{V_{CS_LMT}}{I_{OUT}}$$

Where:

I_{OUT} is the average current of pre-converter.
 V_{CS_LMT} is internal CS limit.

Drain Voltage Control

BP5656E removes current ripple by controlling the voltage of DRAIN. In normal operation, DRAIN voltage is set as:

$$V_{D_AVG} \approx 0.5 \cdot (0.5 + 7.4 \cdot V_{CS}) \cdot \left(1 + \frac{R_U}{R_D}\right)$$

Where:

V_{CS} is the average voltage of CS pin, R_U is the upper resistance of FB divider; R_D is the lower resistance of FB divider.



BP5656E

晶丰明源半导体 Current Ripple Remover for Dimmable LED Driver

Protections

BP5656E offers multiple protections, including drain voltage OVP, LED short protection and over temperature protection.

Over Temperature Protection

When the junction temperature is higher than OTP threshold, the internal reference voltage will be reduced to control the drain voltage. So the ripple removing effect will be decreased gradually to control the temperature of MOSFET to improve the system reliability.

OVP of MOSFET Drain Voltage

When the output current of pre-converter is increased rapidly, DRAIN voltage will also goes high rapidly. When FB pin detects that DRAIN voltage is high than threshold, BP5656E will increase the gate voltage of the MOSFET to decrease the drain voltage. By this function, DRAIN voltage can be controlled under certain limit and LED current overshoot can be eliminated. OVP voltage of is set as:

$$V_{D_OVP} \approx (0.5 + 7.4 \cdot V_{CS}) \cdot \left(1 + \frac{R_U}{R_D}\right)$$

V_{CS} is the average voltage of CS pin, R_U is the upper resistance of FB divider; R_D is the lower resistance of FB divider.

Output Short Protection

When Led is shorted, MOSFET Drain voltage increases rapidly to the output voltage of pre-converter. FB voltage is internally clamped to V_{FB_CLP} . If the clamping current is higher than SCP threshold, the IC will enter short protection, and the system is reduced to improve reliability. SCP voltage is set as:

$$V_{D_SCP} \approx V_{FB_CLP} \cdot \left(1 + \frac{R_U}{R_D}\right) + I_{FB_SCP} \cdot R_U$$

Where:

R_U is the upper resistance of FB divider; R_D is

the lower resistance of FB divider. I_{FB_SCP} is the current reference for FB clamping current, while V_{FB_CLP} is the internal clamping voltage in LED short condition.

PCB Layout

The following rules should be followed in BP5656E PCB layout:

Heat Dissipation

Increase the cooper area of MOSFET Drain as possible to improve the thermal condition.

anti-interference

Reduce the trace length of FB pin and CS pin as possible. Keep the resistor as close the IC as possible.

Package

