

Description

The BP6903 is a high voltage, high speed half-bridge pre-driver for power MOSFET and IGBT. It has inputs for both high side and low side, and two output channels with internal dead time to avoid cross-conduction.

The input logic level is compatible with 3.3V/5V/15V signal. The floating high side channel can drive an N-channel power MOSFET or IGBT up to 600V.

Features

- Floating channel operation up to 600V
- Robust at negative transient voltage
- Gate drive supply range from 10V to 20V
- 3.3V, 5V and 15V input logic input compatible
- Reverse input for low side
- UVLO for both high side and low side
- Built-in dead time
- Available in SOP8 package

Typical Application

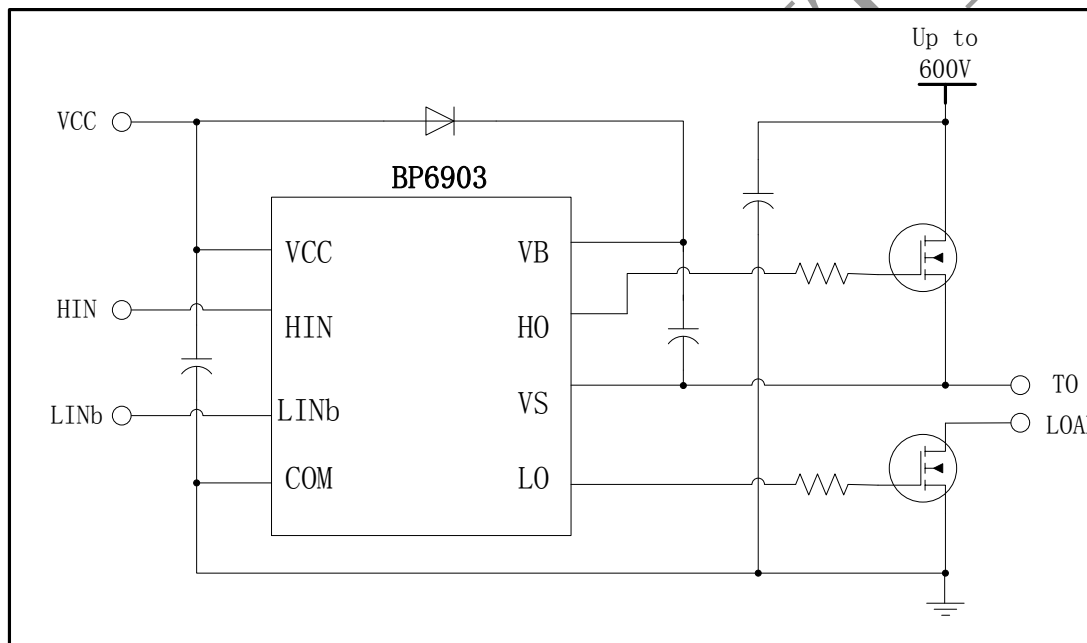

Figure 1. Typical application circuit

Ordering Information

Part Number	Package	Operation Temperature	Package Method	Marking
BP6903	SOP8	-40 °C to 105 °C	Tape 4,000 Piece/Roll	BP6903 XXXXXY XXY

Pin Configuration and Marking Information

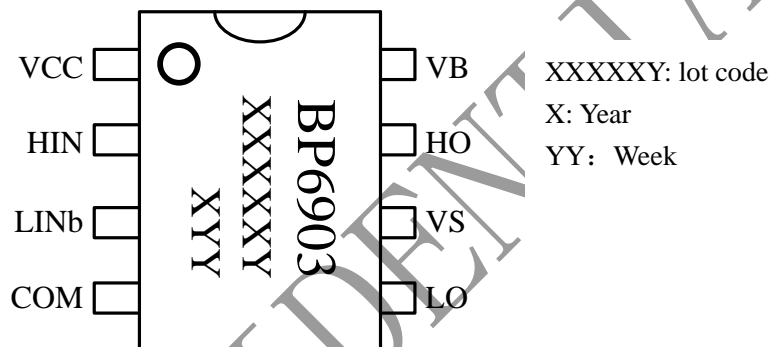

Figure 2. Pin configuration

Pin Definition

Pin No.	Name	Description
1	VCC	Low side and logic supply voltage
2	HIN	Logic input for high side, in phase with HO
3	LINb	Logic input for low side, out of phase with LO
4	COM	Logic ground and low side driver return
5	LO	Low side driver output
6	VS	High side driver return
7	HO	High side driver output
8	VB	High side floating supply



Absolute Maximum Ratings (note 1)

Symbol	Parameters	Min.	Max.	Unit
V _B	High side floating supply voltage	-0.3	625	V
V _S	High side offset voltage	V _B - 25	V _B + 0.3	V
V _{HO}	High side driver output voltage	V _S - 0.3	V _B + 0.3	V
V _{CC}	Low side and logic supply voltage	-0.3	25	V
V _{LO}	Low side driver output voltage	-0.3	V _{CC} + 0.3	V
HIN/ LINb	Logic input voltage	-0.3	V _{CC} + 0.3	V
dV _s /dt	Allowable offset voltage slew rate	--	50	V/ns
P _{DMAX}	Package power dissipation (note 2)	--	0.625	W
θ _{JA}	Thermal resistance, junction to ambient	--	200	°C/W
T _J	Junction temperature	-40	150	°C
T _{STG}	Storage temperature	-55	150	°C
	ESD (note 3)		2	KV

Note 1: Stresses beyond those listed under “absolute maximum ratings” may cause permanent damage to the device. Under “recommended operating conditions” the device operation is assured, but some particular parameter may not be achieved. The electrical characteristics table defines the operation range of the device, the electrical characteristics is assured on DC and AC voltage by test program. For the parameters without minimum and maximum value in the EC table, the typical value defines the operation range, the accuracy is not guaranteed by spec.

Note 2: The maximum power dissipation decrease if temperature rise, it is decided by T_{JMAX}, θ_{JA}, and environment temperature (T_A). The maximum power dissipation is the lower one between P_{DMAX} = (T_{JMAX} - T_A) / θ_{JA} and the number listed in the maximum table.

Note 3: Human Body mode, 100pF capacitor discharge on 1.5k Ω resistor.



晶丰明源半导体

BP6903

600V Half-Bridge Pre-Driver

Recommended Operation Conditions

Symbol	Parameters	Min.	Max.	Unit
V_B	High side floating supply voltage	$V_S + 10$	$V_S + 20$	V
V_S	High side offset voltage	-5	600	V
V_{HO}	High side driver output voltage	V_S	V_B	V
V_{CC}	Low side and logic supply voltage	10	20	V
V_{LO}	Low side driver output voltage	0	V_{CC}	V
HIN/ LINb	Logic input voltage	0	V_{CC}	V



Electrical Characteristics (note 4) (Unless otherwise specified, $V_{CC}=V_{BS}=15V$ and $T_A=25\text{ }^\circ\text{C}$)

Symbol	Parameter	Condition	Min.	Typ.	Max.	Unit
Static Electrical Characteristics						
V_{CC_ON}	V_{CC} and V_{BS} under voltage rising threshold		8	8.8	9.8	V
V_{BS_ON}						
V_{CC_UVLO}	V_{CC} and V_{BS} under voltage falling threshold		7.2	8.0	8.8	V
V_{BS_UVLO}						
V_{CC_HYS}	V_{CC} and V_{BS} under voltage hysteresis voltage		0.5	0.8	1.2	V
V_{BS_HYS}						
I_{QCC}	Quiescent V_{CC} supply current	$HIN=0V, LINb=5V$	-	200	300	μA
I_{QBS}	Quiescent V_{BS} supply current	$HIN=0V, LINb=5V$	-	50	100	μA
I_{LK}	Offset supply leakage current	$V_B=V_S=620V$	-	-	50	μA
V_{IH}	Logic "1" input voltage		2.8	-	-	V
V_{IL}	Logic "0" input voltage		-	-	0.6	V
I_{HIN_H}	Logic "1" input bias current	$HIN=5V$	-	5	10	μA
I_{HIN_L}	Logic "0" input bias current	$HIN=0V$	-	-	1	μA
I_{LIN_H}	Logic "1" input bias current	$LINb=5V$	-	-	1	μA
I_{LIN_L}	Logic "0" input bias current	$LINb=0V$	-	5	10	μA
V_{OH}	High level output voltage	$I_O=20\text{mA}$	-	-	1.0	V
V_{OL}	Low level output voltage	$I_O=20\text{mA}$	-	-	1.0	V
I_{O+}	Output high short circuit pulse current	$V_O=0V, V_{IN}=5V,$ Pulse Width < 10 μS	130	210	-	mA
I_{O-}	Output low short circuit pulse current	$V_O=15V, V_{IN}=0V,$ Pulse Width < 10 μS	240	320	-	mA
Dynamic Electrical Characteristics ($C_L=1\text{nF}$)						
t_{on}	Turn-on propagation delay	$V_S=0V$	-	680	820	ns
t_{off}	Turn-off propagation delay	$V_S=0V$ or 600V	-	160	250	
t_r	Turn-on rise time		-	100	170	
t_f	Turn-off fall time		-	50	90	
DT	Dead time		400	520	650	
MT	Delay match	t_{on} & t_{off} for (HS-LS)	-	-	60	

Note 4: The maximum and minimum parameters specified are guaranteed by test, the typical value are guaranteed by design, characterization and statistical analysis.

Internal Block Diagram

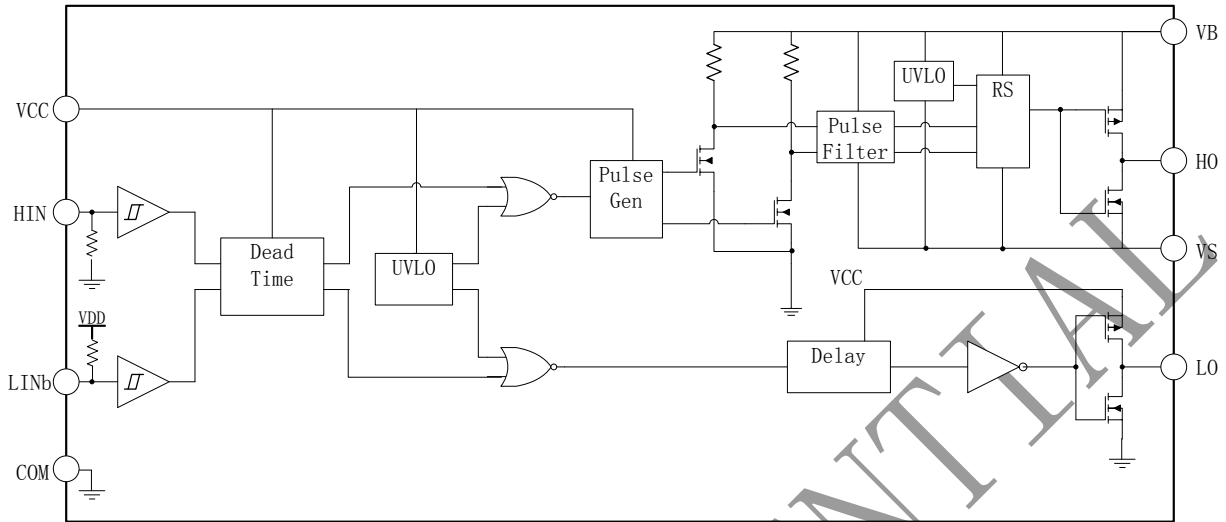

Figure 3. Internal block diagram

Waveforms

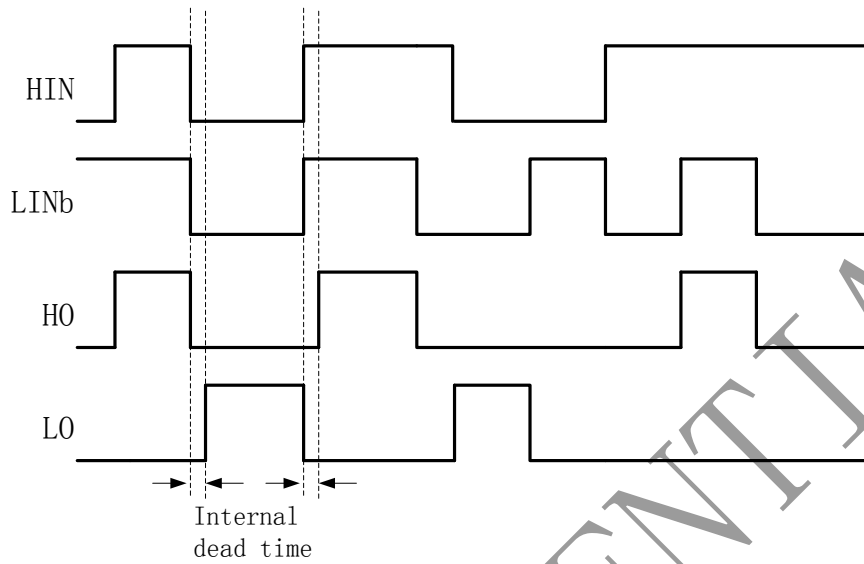

Figure 4. Input/ Output Timing Diagram

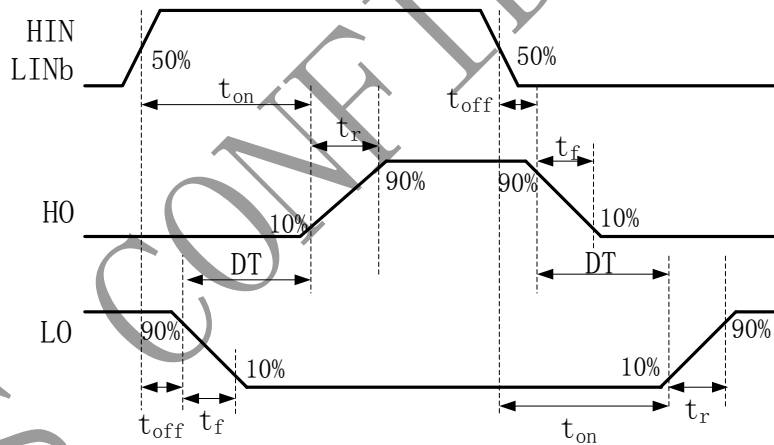

Figure 5. Switching Timing Definition

Physical Dimensions
