

BP85226DF

Ultra-high Integration Off-line Switcher IC

Description

The BP85226DF is a high performance, highly integrated power supply switcher IC with low standby consumption. The BP85226DF can be configured as buck, buck-boost topologies for universal 85~265V AC inputs.

The BP85226DF integrates a 650V power MOSFET, a high-voltage current source for self-biasing, a current sensing circuit, an output feedback circuit, a freewheeling diode and an advanced controller. External VCC capacitor and loop compensation components can be eliminated, which reduces cost and size of overall power systems, and improves reliability.

The BP85226DF employs advanced multi-mode control algorithm. As a result, the no-load power consumption and the average efficiency have been improved, and the audible noise is reduced.

The BP85226DF features comprehensive protections, including short circuit protection (SCP), output over voltage protection (OVP), over load protection (OLP), FB open loop protection, cycle-by-cycle current limit, and over temperature protection (OTP).

The BP85226DF is available for SOP-7 package.

Features

- Integrated VCC capacitor, freewheeling diode and feedback diode
- Integrated 650V power MOSFET
- Integrated high-voltage current source for self-biasing
- 50mW no load consumption at 230VAC
- Fixed 5V output
- Excellent transient response, low output ripple
- Optimized line and load regulation
- Reduced audible noise at light load
- Adaptive switching frequency, 36kHz maximum
- Frequency modulation for EMI improvement
- Internal soft start
- Comprehensive protections
 - Short circuit protection (SCP)
 - Over voltage protection (OVP)
 - Over load protection (OLP)
 - Open loop protection
 - Cycle-by-cycle current limit
 - Over temperature protection (OTP)

Applications

- Home appliances
- Motor driver standby power
- IoT, smart home, smart LED drivers



SOP-7 package

Typical Application

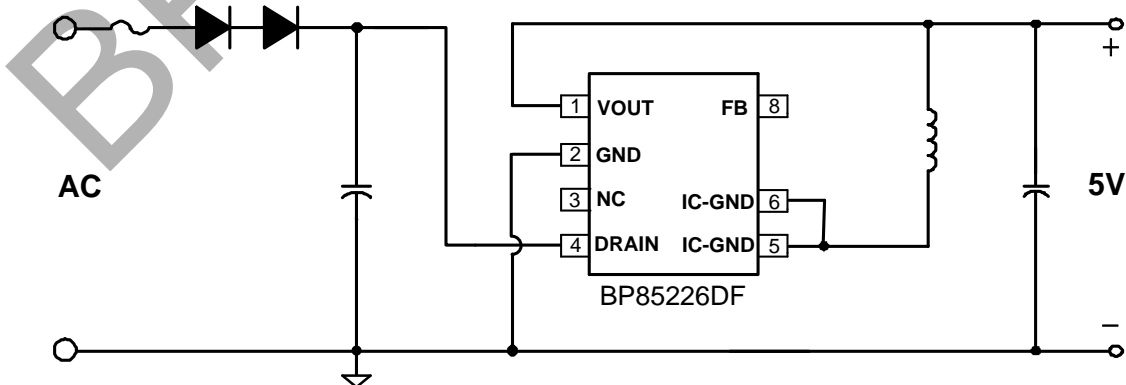

Figure 1. Typical buck application with the BP85226DF

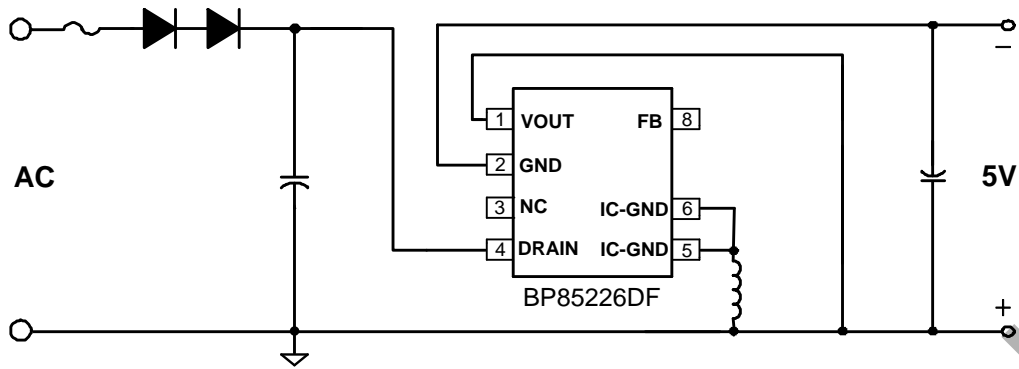
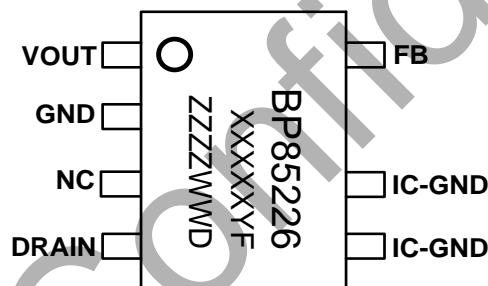

Figure 2. Typical buck-boost application with the BP85226DF

Ordering Information

Part Number	Package	Packing	Marking
BP85226DF	SOP-7	Tape & Reel 4,000 pcs/Reel	BP85226 XXXXXYF ZZZZWWD

Pin Configuration and Marking Information



BP85226: Part number
XXXXXYF: Lot code
ZZZZ: Internal code
WW: Week code
D: Package type(D:SOP)

Figure 3. SOP-7 pin configuration

Pin Functions

Pin NO.	Pin Name	Description
1	VOUT	Output voltage pin. Anode of the internal feedback diode.
2	GND	Ground reference for the output voltage. Anode of the internal freewheeling diode.
3	NC	Not connected.
4	DRAIN	Drain connection of the internal power MOSFET. Input of the high-voltage current source.
5, 6	IC-GND	Ground reference for the IC. Source connection of the internal power MOSFET. Cathode of the internal freewheeling diode.
8	FB	Voltage feedback pin. Cathode of the internal feedback diode. No external connection is required.

Disclaimer

The information provided in this datasheet is believed to be accurate and reliable. However, Bright Power Semiconductor (BPS) reserves the right to make changes at any time without prior notice.

No license, to any intellectual property right owned by BPS or any other third party, is granted under this document. BPS provides information in this datasheet "AS IS" and with all faults, and makes no warranty, express or implied, including but not limited to, the accuracy of the information provided in this datasheet, merchantability, fitness of a specific purpose, or non-infringement of intellectual property rights of BPS or any other third party. BPS disclaims any and all liabilities arising out of this datasheet or use of this datasheet, including without limitation consequential or incidental damages.

BPS Confidential