

BP85928D

High Integration Off-line Switcher



Description

The BP85928D is a high performance, highly integrated power supply switcher IC with low standby consumption. The BP85928D can be configured as buck, buck-boost topologies for universal 85~265V AC inputs.

The BP85928D integrates a 650 V power MOSFET, a high-voltage current source for self-biasing, a current sensing circuit, an output feedback circuit, and an advanced controller. External loop compensation components can be eliminated, which reduces cost and size of overall power systems, and improves reliability.

The BP85928D employs multi-mode control algorithm. As a result, the no-load power consumption and the average efficiency have been improved, and the audible noise is reduced.

The BP85928D features comprehensive protections, including short circuit protection (SCP), output over voltage protection (OVP), over load protection (OLP), cycle-by-cycle current limit, and over temperature protection (OTP).

The BP85928D is available in SOP-8 package.

Features

- Integrated 650V power MOSFET
- Integrated high-voltage current source for self-biasing
- Integrated output feedback circuit
- Fixed 5V output
- Excellent transient response, low output ripple
- Reduced audible noise at light load
- Adaptive switching frequency, 40kHz maximum
- Frequency modulation for EMI improvement
- Internal soft start
- Comprehensive protections
 - Short circuit protection (SCP)
 - Over voltage protection (OVP)
 - Over load protection (OLP)
 - Cycle-by-cycle current limit
 - Over temperature protection (OTP)

Applications

- Home appliances
- Motor driver standby power
- IoT, smart home, smart LED drivers



Typical Application

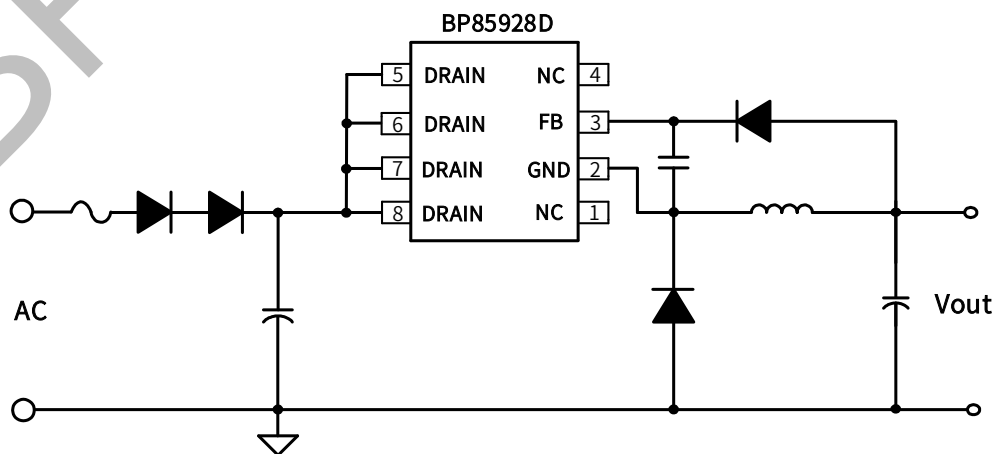

Figure1. Typical buck application with the BP85928D

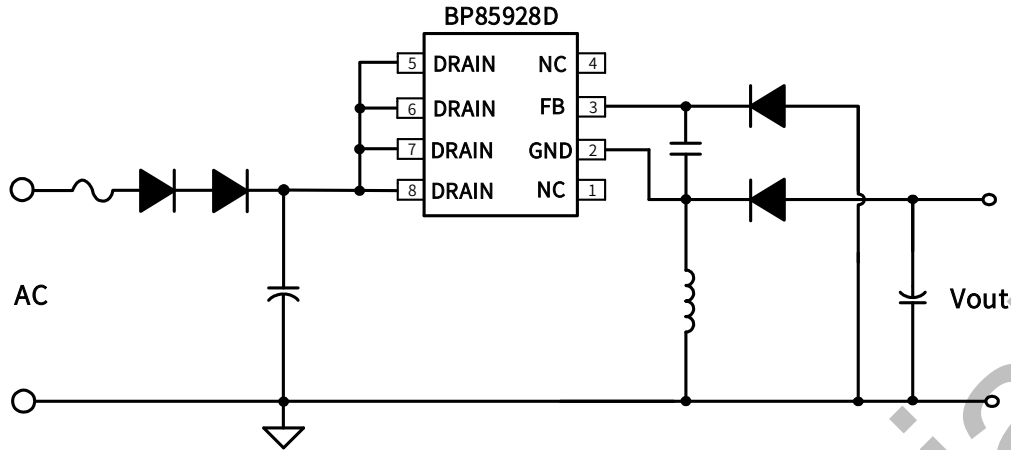
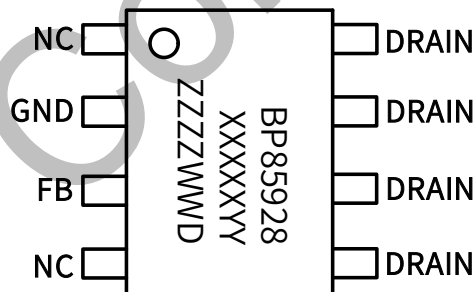

Figure2. Typical buck-boost application with the BP85928D

Ordering Information

Part Number	Package	Packing	Marking
BP85928D	SOP-8	Tape & Reel 4,000 pcs/Reel	BP85928 XXXXXXYY ZZZZWWD

Pin Configuration and Marking Information



BP85928: Part number
XXXXXXYY: Lot code
ZZZZ: Internal code
WW: Week code
D: Package type (D:SOP)

Figure 3. SOP-8 pin configuration

Pin Functions

Pin NO.	Pin Name	Description
1、 4	NC	Not connected.
2	GND	Ground reference for the IC. Source connection of the internal power MOSFET.
3	FB	Voltage feedback pin.
5、 6、 7、 8	DRAIN	Drain connection of the internal power MOSFET. Input of the high-voltage current source.

Disclaimer

The information provided in this datasheet is believed to be accurate and reliable. However, Bright Power Semiconductor (BPS) reserves the right to make changes at any time without prior notice.

No license, to any intellectual property right owned by BPS or any other third party, is granted under this document. BPS provides information in this datasheet "AS IS" and with all faults, and makes no warranty, express or implied, including but not limited to, the accuracy of the information provided in this datasheet, merchantability, fitness of a specific purpose, or non-infringement of intellectual property rights of BPS or any other third party. BPS disclaims any and all liabilities arising out of this datasheet or use of this datasheet, including without limitation consequential or incidental damages.

BPS Confidential