

Description

The BP9111A is a high precision primary-side feedback and regulation controller for LED lighting, it operates in constant current control mode and is designed to work in inductor current discontinuous conduction mode and especially suitable for flyback convertor under universal input. The output power of system is recommended to less than 3W.

The device integrates a 650V power MOSFET. With very few external components, the converter achieves excellent constant current control. And it does not need auxiliary winding for powering the IC or voltage sensing, hence the system size and cost is greatly reduced.

Since using the proprietary high accurate current sense method, the BP9111A realizes $\pm 6\%$ accuracy of LED current along with excellent line and load regulation.

The BP9111A offers rich protection functions including LED open/short circuit protection, thermal regulation, V_{CC} under voltage protection.

Features

- Available in CPC4 Package
- Internal 650V Power MOSFET
- Constant current control without secondary sense and feedback circuit.
- Integrated HV JFET for VCC Power Supply
- No Auxiliary winding for sensing and supplying
- Universal input voltage
- $\pm 6\%$ LED current accuracy
- LED short and open circuit protection
- VCC under-voltage protection
- Thermal regulation

Application

- GU10 LED spot light
- LED Bulb
- Other LED lighting

Typical Application

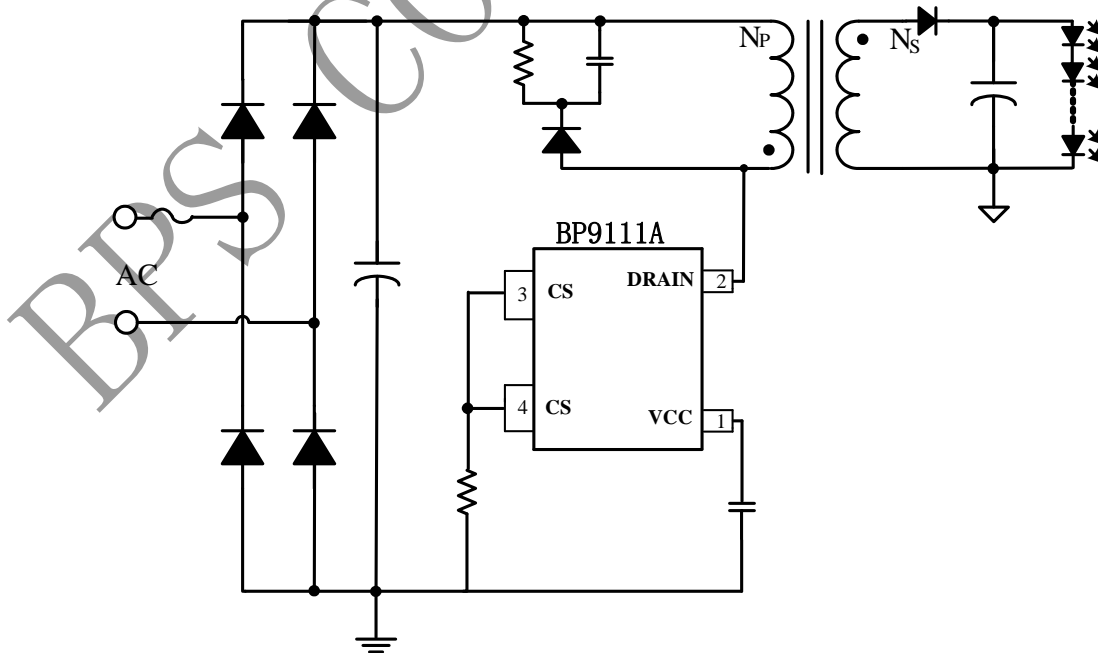

Figure 1. Typical application circuit for BP9111A

Ordering Information

Part Number	Package	Operating Temperature	Packing Method	Marking
BP9111A	CPC4	-40 °C to 105 °C	15,000 pcs/Reel	9111A WXY Y

Pin Configuration and Marking Information

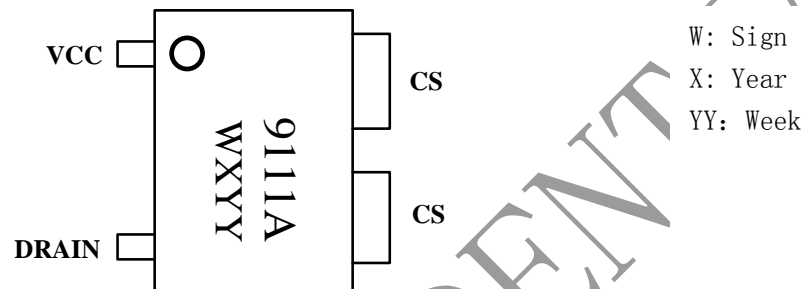

Figure 2. Pin configuration

Pin Definition

Pin No.	Name	Description
1	VCC	Power supply
2	DRAIN	Internal high voltage MOSFET Drain Current sense.
3, 4	CS	This pin connects a current sense resistor to GND to detect the primary current of transformer.

Absolute Maximum Ratings (note1)

Symbol	Parameters	Range	Units
DRAIN	Internal HV MOSFET drain voltage	-0.3~650	V
VCC	Power supply	-0.3~8.5	V
P _{DMAX}	Power dissipation (note2)	0.4	W
θ _{JA}	Thermal resistance (Junction to Ambient)	150	°C/W
T _J	Operating junction temperature	-40 to 150	°C
T _{STG}	Storage temperature range	-55 to 150	°C
	ESD (note3)	2	KV

Note 1: Stresses beyond those listed under “absolute maximum ratings” may cause permanent damage to the device. Under “recommended operating conditions” the device operation is assured, but some particular parameter may not be achieved. The electrical characteristics table defines the operation range of the device, the electrical characteristics is assured on DC and AC voltage by test program. For the parameters without minimum and maximum value in the EC table, the typical value defines the operation range, the accuracy is not guaranteed by spec.

Note 2: The maximum power dissipation decrease if temperature rise, it is decided by T_{JMAX}, θ_{JA}, and environment temperature (T_A). The maximum power dissipation is the lower one between P_{DMAX} = (T_{JMAX} - T_A) / θ_{JA} and the number listed in the maximum table.

Note 3: Human Body mode, 100pF capacitor discharge on 1.5KΩ resistor

Recommended Operation Conditions

Symbol	Parameter	Range	Unit
P _{OUT 1}	Output power (input voltage 85V~265V)	< 3	W
F _{OP}	System operating frequency	<100	KHz



晶丰明源半导体

BP9111A

High Precision PSR Constant Current LED Driver

Electrical Characteristics (Notes 4, 5) (Unless otherwise specified, $V_{CC}=7V$ and $T_A=25^\circ C$)

Symbol	Parameter	Conditions	Min	Typ	Max	Units
Supply Voltage Section						
V_{CC}	VCC operating voltage	Drain=100V		7.3		V
V_{CC_ON}	Turn on threshold voltage	V_{CC} rising		6.6		V
V_{CC_UVLO}	Turn off threshold voltage	V_{CC} falling		5.7		V
I_{ST}	V_{CC} startup current	$V_{CC}=V_{CC_ON}-1V$		0.6	1.2	mA
I_{CC}	V_{CC} operating current			140	300	μA
Current Sense Section						
V_{CS_TH}	Threshold voltage for peak current limit		580	600	620	mV
T_{LEB}	Leading edge blanking time for current sense			500		ns
T_{DELAY}	Switch off delay time			200		ns
Internal Time Control Section						
T_{OFF_MIN}	Minimum OFF Time			5		μs
T_{OFF_MAX}	Maximum OFF Time			300		μs
MOSFET Section						
R_{DS_ON}	Static Drain-source On-resistance	$V_{GS}=7V/I_{DS}=0.1A$		30		Ω
BV_{DSS}	Drain-Source Breakdown Voltage	$V_{GS}=0V/I_{DS}=250\mu A$	650			V
Thermal Regulation Section						
T_{REG}	Thermal Regulation Temperature			140		$^\circ C$

Note 4: production testing of the chip is performed at $25^\circ C$.

Note 5: the maximum and minimum parameters specified are guaranteed by test, the typical value are guaranteed by design, characterization and statistical analysis

Internal Block Diagram

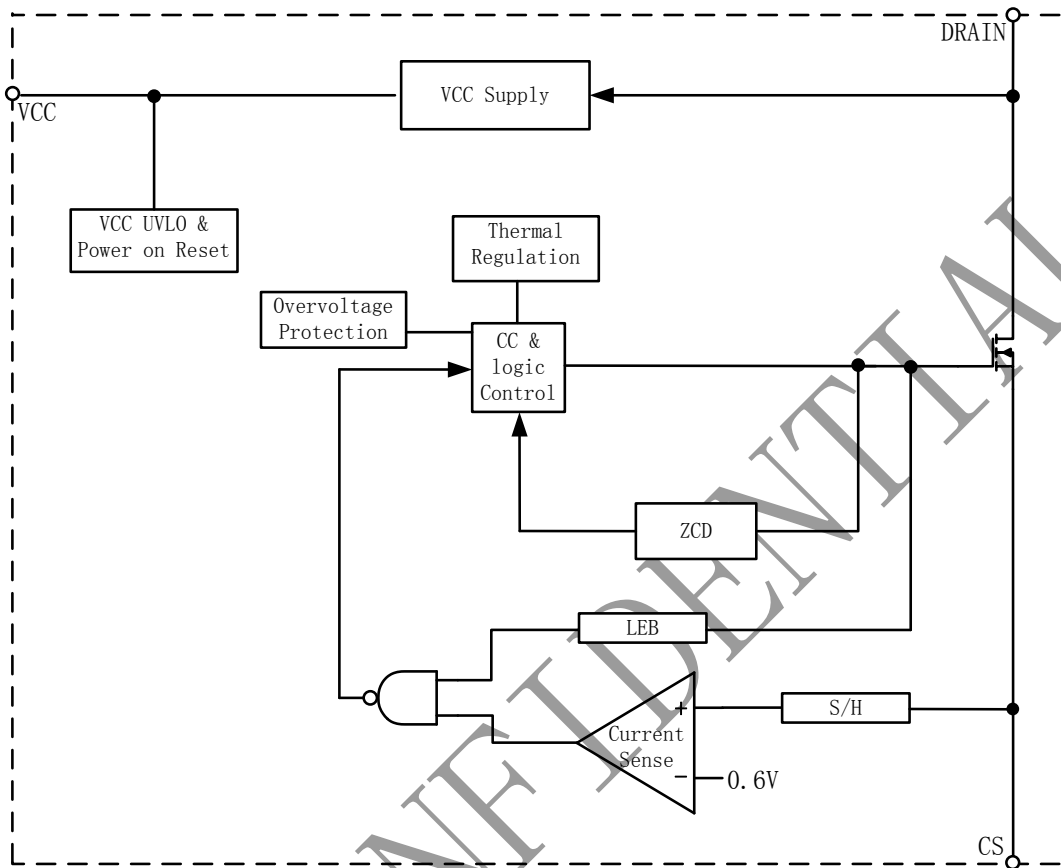

Figure 3. BP9111A Internal Block Diagram

Application Information

The BP9111A is a high precision primary-side feedback and regulation controller for LED lighting. The device integrates a 650V power MOSFET. With very few external components, the converter achieves excellent constant current control. And it does not need auxiliary winding for powering the IC or voltage sensing, hence the system size and cost is greatly reduced.

Start Up

After system powered up, the VCC pin capacitor is charged up by internal HV JFET. When the VCC pin voltage reaches the turn on threshold, the internal circuits start operating. The HV JFET will

still supply operating current when the IC is working and keep the VCC voltage at 7.3V.

Constant Current Control

Cycle-by-Cycle current sense is adopted in BP9111A, the CS is connected to the current sense comparator, and the voltage on CS will be compared with the internal 600mV reference voltage, the MOSFET will be switched off when the voltage on CS reaches the threshold. The output of the comparator includes a 500ns leading edge blanking time.

The primary peak current is given by:

$$I_{PK} = \frac{600}{R_{CS}} (mA)$$



The primary peak current is given by:

$$I_{LED} = \frac{I_{P_PK}}{4} \times \frac{N_P}{N_S}$$

Where,

N_P : primary winding turns of transformer

N_S : secondary winding turns of transformer

I_{P_PK} : peak current in MOSFET

Operating Switching Frequency

The BP9111A is designed to work in discontinuous conduction mode and no external loop compensation component is required while maintaining stability. The maximum duty cycle is limited to 42%. The maximum switching frequency at normal operation is suggested to set below 100KHz. If the maximum frequency is set too high, it will affect the number of maximum series LED lamps. If set too low, the LED open circuit voltage will be too high.

The maximum and minimum switching frequency is limited in BP9111A to ensure the stability of system.

The switching frequency can be set by the formula:

$$f = \frac{N_P^2 \times V_{LED}}{8 \times N_S^2 \times L_P \times I_{LED}}$$

Where, L_P is the primary winding inductance of transformer.

Protection Function

The BP9111A offers rich protection functions including LED open/short circuit protection, thermal regulation, V_{CC} under voltage protection.

When the LED is open circuit, the output voltage increases gradually, and the demagnetization time gets shorter. When the demagnetization time is less

5us set by chip, chip will trigger the OVP.

When the LED short circuit is detected, the system works at low frequency (3kHz), so the system power consumption is very low.

Thermal Regulation

The BP9111A integrates thermal regulation function. When the system is over temperature, the output current is gradually reduced; the output power and thermal dissipation are also reduced. The system temperature is regulated and the system reliability is improved. The thermal regulation temperature is set to 140°C internally.

PCB Layout

The following rules should be followed in BP9111A PCB layout:

Bypass Capacitor

The bypass capacitor on V_{CC} pin should be as close as possible to the V_{CC} Pin.

CS Resistor

The CS resistor should be as close as possible to the CS pin, and makes the connection to the V_{CC} bypass capacitor as short as possible.

The Area of Power Loop

The area of main current loop should be as small as possible to reduce EMI radiation, such as the inductor, the power MOSFET, the output diode and the bus capacitor loop.

CS Pin

To increase the copper area of CS pin for better thermal dissipation.

Physical Dimensions

