

Description

BP9911CB is a high precision Buck constant current LED driver. The device operates in critical conduction mode and is suitable for 85Vac~265Vac universal input offline LED lighting.

The BP9911CB integrates a 500V power MOSFET. With patent pending MOSFET driving technique, the operating current of the IC is as low as 180uA. It doesn't need the auxiliary winding for VCC supply. It can achieve excellent constant current performance with very few external components, so the system cost and size are minimized.

BP9911CB utilizes patent pending current control method. It can achieve precise output current and excellent line regulation. The driver operates in critical conduction mode, the output current does not change with the inductance and output voltage.

The BP9911CB offers rich protections to improve the system reliability, including LED short circuit protection, VCC under voltage protection and thermal regulation function.

Typical Application

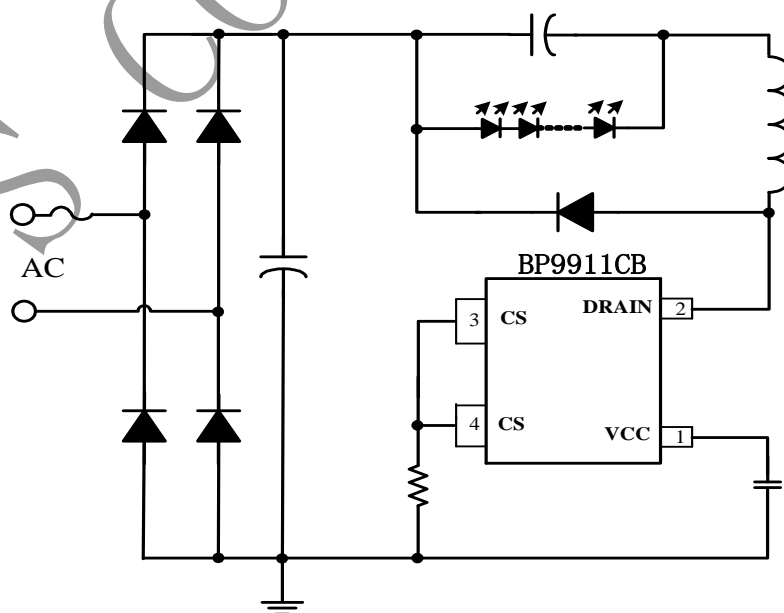

Figure 1. Typical application circuit for BP9911CB

Features

- Internal 500V Power MOSFET
- Integrated HV JFET for VCC Power Supply
- Critical Conduction Mode Operation
- Low Operating Current
- ±5% LED Output Current Accuracy
- LED Short Protection
- VCC Under Voltage Protection
- Thermal Regulation Function
- Available in CPC4 Package

Applications

- LED Candle Light
- LED Bulb
- Other LED Lighting

Ordering Information

Part Number	Package	Operating Temperature	Packing Method	Marking
BP9911CB	CPC4	-40 °C to 105 °C	Tape 15,000 Pcs/Reel	9911C WXYXB

Pin Configuration and Marking Information

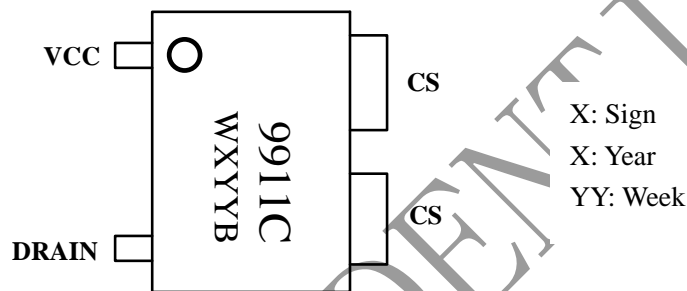

Figure 2. Pin configuration

Pin Definition

Pin No.	Name	Description
1	VCC	Power Supply Pin.
2	DRAIN	Internal HV Power MOSFET Drain.
3, 4	CS	IC GND Pin, also for Current Sense. Connect a sense resistor between this pin and power GND.