

### Description

BP9912CB is a high precision Buck constant current LED driver. The device operates in critical conduction mode and is suitable for 85Vac~265Vac universal input offline LED lighting.

The BP9912CB integrates a 500V power MOSFET. With patent pending MOSFET driving technique, the operating current of the IC is as low as 180uA. It doesn't need the auxiliary winding for VCC supply. It can achieve excellent constant current performance with very few external components, so the system cost and size are minimized.

BP9912CB utilizes patent pending current control method. It can achieve precise output current and excellent line regulation. The driver operates in critical conduction mode, the output current does not change with the inductance and output voltage.

The BP9912CB offers rich protections to improve the system reliability, including LED short circuit protection, VCC under voltage protection and thermal regulation function.

### Typical Application

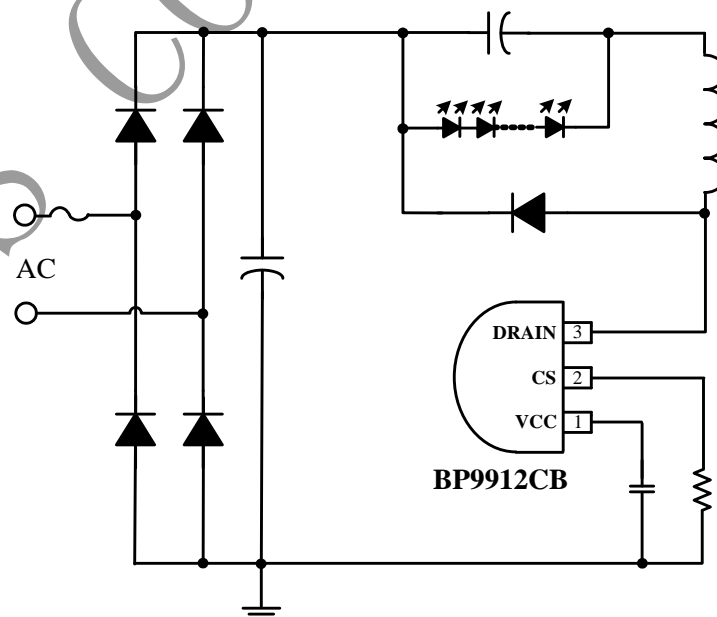

Figure 1. Typical application circuit for BP9912CB

### Features

- Internal 500V Power MOSFET
- Integrated HV JFET for VCC Power Supply
- Critical Conduction Mode Operation
- Low Operating Current
- ±5% LED Output Current Accuracy
- LED Short Protection
- VCC Under Voltage Protection
- Thermal Regulation Function
- Available in TO-92 Package

### Applications

- LED Candle Light
- LED Bulb
- Other LED Lighting

### Ordering Information

Part Number	Package	Operating Temperature	Packing Method	Marking
BP9912CBY	T0-92	-40 °C to 105 °C	Unshaped without tape 1,000pcs/bag	BP9912C XXXXXY XXYY
BP9912CBZ	T0-92	-40 °C to 105 °C	Shaped without tape 1,000pcs/bag	BP9912C XXXXXY XXYY
BP9912CBT	T0-92	-40 °C to 105 °C	Shaped in tape 2,000 pcs/box	BP9912C XXXXXY XXYY

### Pin Configuration and Marking Information

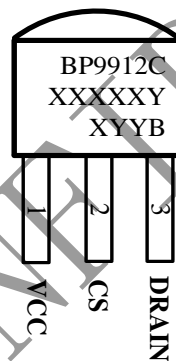

XXXXXY: Lot Code

X: Year

YY: Week

Figure 2. Pin configuration

### Pin Definition

Pin No.	Name	Description
1	VCC	Power Supply Pin.
2	CS	IC GND Pin, also for Current Sense. Connect a sense resistor between this pin and power GND.
3	DRAIN	Internal HV Power MOSFET Drain.



### Absolute Maximum Ratings (note1)

Symbol	Parameters	Range	Units
DRAIN	Internal HV MOSFET drain voltage	-0.3~500	V
I <sub>DMAX</sub>	Maximum Drain Current@ T <sub>J</sub> =100°C	400	mA
VCC	Power Supply voltage	-0.3~8.5	V
P <sub>DMAX</sub>	Power dissipation (note 2)	0.45	W
θ <sub>JA</sub>	Thermal resistance (Junction to Ambient)	140	°C/W
T <sub>J</sub>	Operating junction temperature	-40 to 150	°C
T <sub>STG</sub>	Storage temperature range	-55 to 150	°C
	ESD (note 3)	2	kV

**Note 1:** Stresses beyond those listed under “absolute maximum ratings” may cause permanent damage to the device. Under “recommended operating conditions” the device operation is assured, but some particular parameter may not be achieved. The electrical characteristics table defines the operation range of the device, the electrical characteristics is assured on DC and AC voltage by test program. For the parameters without minimum and maximum value in the EC table, the typical value defines the operation range, the accuracy is not guaranteed by spec.

**Note 2:** The maximum power dissipation decrease if temperature rise, it is decided by T<sub>JMAX</sub>, θ<sub>JA</sub>, and environment temperature (T<sub>A</sub>). The maximum power dissipation is the lower one between P<sub>DMAX</sub> = (T<sub>JMAX</sub> - T<sub>A</sub>) / θ<sub>JA</sub> and the number listed in the maximum table.

**Note 3:** Human Body mode, 100pF capacitor discharge on 1.5kΩ resistor

### Recommended Operation Conditions

Symbol	Parameter	Range	Unit
I <sub>LED max</sub>	Maximum Output LED current	170	mA
V <sub>LED min</sub>	Minimum LED Loading Voltage	>10	V



晶丰明源半导体

# BP9912CB

## Non-isolated Buck Constant Current LED Driver

### Electrical Characteristics (Notes 4, 5) (Unless otherwise specified, $V_{CC}=7V$ and $T_A=25^\circ C$ )

Symbol	Parameter	Conditions	Min	Typ	Max	Units
<b>Supply Voltage Section</b>						
$V_{CC}$	$V_{CC}$ Operating Voltage	Drain=100V		7.0		V
$V_{CC\_ON}$	$V_{CC}$ Turn On Threshold	$V_{CC}$ Rising		6.3		V
$V_{CC\_UVLO}$	$V_{CC}$ Turn off Threshold	$V_{CC}$ Falling		5.5		V
$I_{ST}$	$V_{CC}$ Startup Current	$V_{CC}=V_{CC\_ON}-1V$		0.3	0.6	mA
$I_{OP}$	$V_{CC}$ Operating Current			110	180	uA
<b>Current Sense Section</b>						
$V_{CS\_TH}$	Threshold Voltage for Peak Current Limit		580	600	620	mV
$T_{LEB}$	Leading Edge Blanking Time for Current Sense			500		ns
$T_{DELAY}$	Switch Off Delay Time			200		ns
<b>Internal Time Control Section</b>						
$T_{OFF\_MIN}$	Minimum OFF Time			2.5		us
$T_{OFF\_MAX}$	Maximum OFF Time			300		us
$T_{ON\_MAX}$	Maximum On Time			35		us
<b>MOSFET Section</b>						
$R_{DS\_ON}$	Static Drain-source On-resistance	$V_{GS}=7V/I_{DS}=0.1A$		15		$\Omega$
$BV_{DSS}$	Drain-Source Breakdown Voltage	$V_{GS}=0V/I_{DS}=250uA$	500			V
<b>Thermal Regulation Section</b>						
$T_{REG}$	Thermal Regulation Temperature			140		$^\circ C$

Note 4: production testing of the chip is performed at 25°C.

Note 5: the maximum and minimum parameters specified are guaranteed by test, the typical value are guaranteed by design, characterization and statistical analysis

## Internal Block Diagram

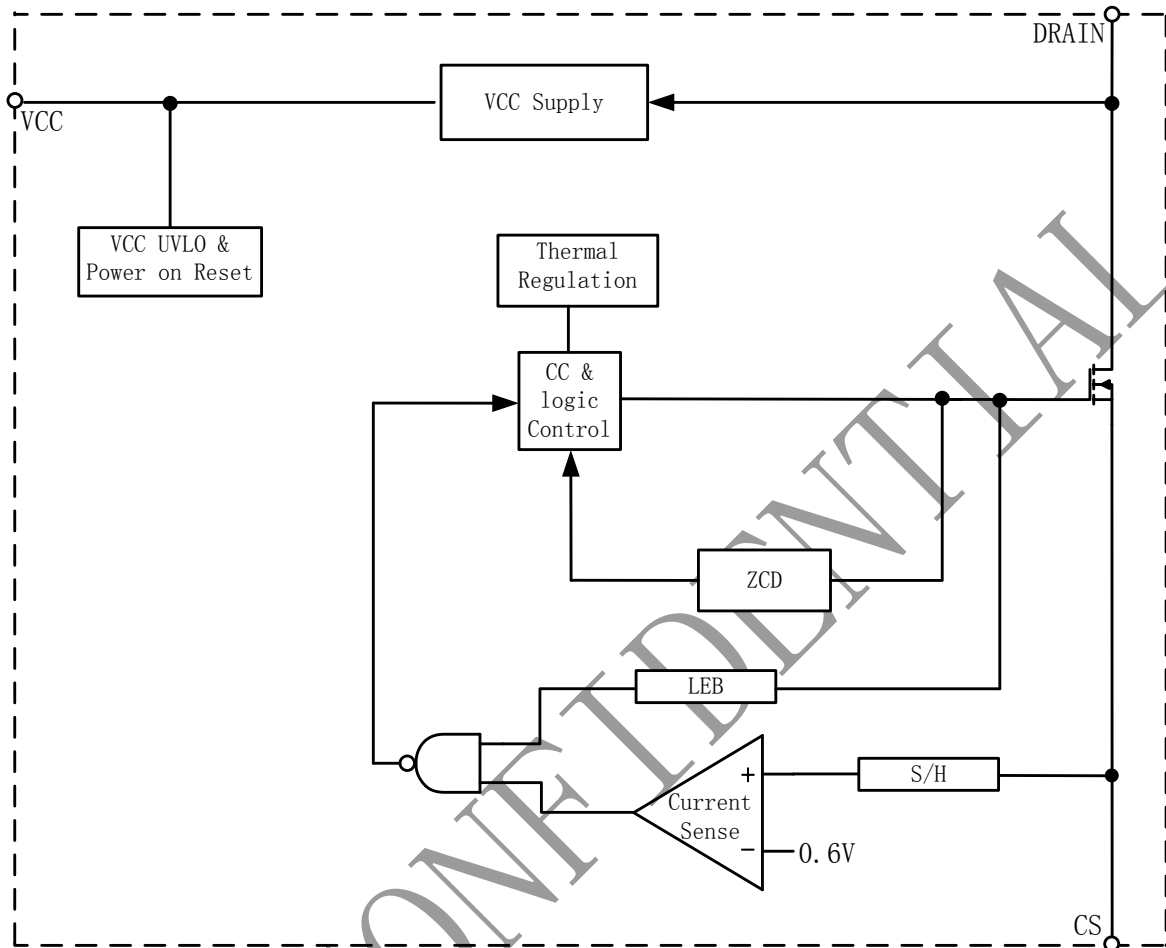

Figure 3. BP9912CB Internal Block Diagram

## Application Information

The BP9912CB is a high performance non-isolated Buck converter specially designed for LED lighting. The device integrates a 500V power MOSFET. With very few external components, the converter achieves excellent constant current control. And it does not need auxiliary winding for powering the IC or voltage sensing, hence the system size and cost is greatly reduced.

### Start Up

After system powered up, the VCC pin capacitor is charged up by internal HV JEFT. When the VCC pin voltage reaches the turn on threshold, the internal circuits start operating. The HV JEFT will still

supply operating current when the IC is working and keep the VCC voltage at 7.0V.

### Constant Current Control

Cycle by Cycle current sense is adopted in BP9912CB, the CS pin is connected to the current sense comparator, and the voltage on CS pin is compared with the internal 600mV reference voltage. The MOSFET will be switched off when the voltage on CS pin reaches the threshold. The CS comparator includes a 500ns leading edge blanking time.

The peak inductor current is given by:



$$I_{PK} = \frac{600}{R_{CS}} (mA)$$

Where,  $R_{CS}$  is the current sense resistor value.

The current in LED can be calculated by the equation:

$$I_{LED} = \frac{I_{PK}}{2}$$

Where,  $I_{PK}$  is the peak current of the inductor.

### Inductor Selection

The BP9912CB works under inductor current critical conduction mode. When the power MOSFET is switched on, the current in the inductor rises up from zero, the on time of the MOSFET can be calculated by the equation:

$$t_{on} = \frac{L \times I_{PK}}{V_{IN} - V_{LED}}$$

Where,

L is the inductance value

$V_{IN}$  is the DC bus voltage after the rectifier bridge

$V_{LED}$  is the voltage on the LED

After the power MOSFET is switched off, the current in the inductor decreases. When the inductor current reaches zero, the power MOSFET is turned on again by IC internal logic. The off time of the MOSFET is given by:

$$t_{off} = \frac{L \times I_{PK}}{V_{LED}}$$

The inductance can be calculated by the equation:

$$L = \frac{V_{LED} \times (V_{IN} - V_{LED})}{f \times I_{PK} \times V_{IN}}$$

The f is the system switching frequency, which is proportional to the input voltage. So the minimum

switching frequency is set at lowest input voltage, and the maximum switching frequency is set at highest input voltage.

The minimum and maximum off time of BP9912CB is set at 2.5us and 300us, respectively. Referring to the equation of  $t_{OFF}$  calculation, if the inductance is too small, the  $t_{OFF}$  may be smaller than the minimum off time, system will operate in discontinuous conduction mode and the output current will be smaller than the designed value. If the inductance is too large, the  $t_{OFF}$  may be larger than the maximum off time, the system will operate in continuous conduction mode and the output current will be higher than the designed value. So it is important to choose a proper inductance.

### Protection Function

The BP9912CB offers rich protection functions to improve the system reliability, including LED short protection,  $V_{CC}$  under voltage protection, thermal regulation.

When the LED short circuit is detected, the system works at low frequency (3kHz), so the system power consumption is very low.

### Thermal Regulation

The BP9912CB integrates thermal regulation function. When the system is over temperature, the output current is gradually reduced; the output power and thermal dissipation are also reduced. The system temperature is regulated and the system reliability is improved. The thermal regulation temperature is set to 140°C internally.

### PCB Layout

The following rules should be followed in BP9912CB PCB layout:

Bypass Capacitor

The bypass capacitor on  $V_{CC}$  pin should be as close as possible to the  $V_{CC}$  Pin.

CS Resistor



晶丰明源半导体

**BP9912CB**  
**Non-isolated Buck Constant Current LED Driver**

---

The CS resistor should be as close as possible to the CS pin, and makes the connection to the V<sub>CC</sub> bypass capacitor as short as possible.

The Area of Power Loop

The area of main current loop should be as small as possible to reduce EMI radiation, such as the inductor, the power MOSFET, the output diode and the bus capacitor loop.

CS Pin

To increase the copper area of CS pin for better thermal dissipation.

BPS CONFIDENTIAL

## Physical Dimensions (Unshaped without tape)

### TO-92 PACKAGE OUTLINE DIMENSIONS

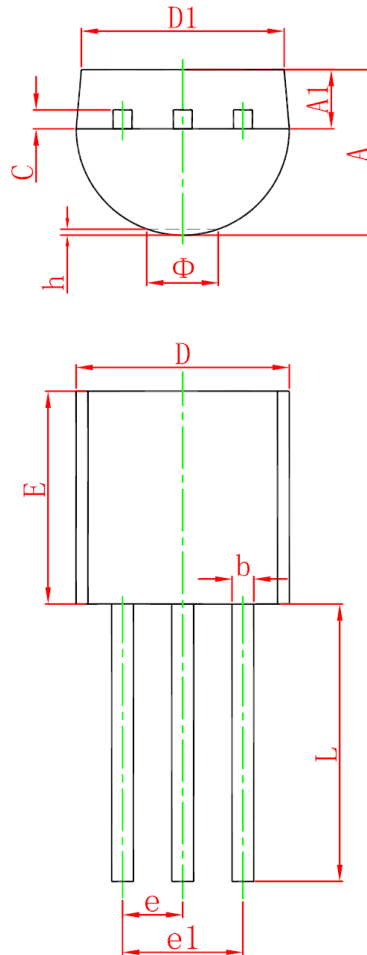

Symbol	Dimensions In Millimeters		Dimensions In Inches	
	Min.	Max.	Min.	Max.
A	3.300	3.700	0.130	0.146
A1	1.100	1.400	0.043	0.055
b	0.380	0.550	0.015	0.022
c	0.360	0.510	0.014	0.020
D	4.300	4.700	0.169	0.185
D1	3.430		0.135	
E	4.300	4.700	0.169	0.185
e	1.270 TYP.		0.050 TYP.	
e1	2.440	2.640	0.096	0.104
L	14.100	14.500	0.555	0.571
$\Phi$		1.600		0.063
h	0.000	0.380	0.000	0.015

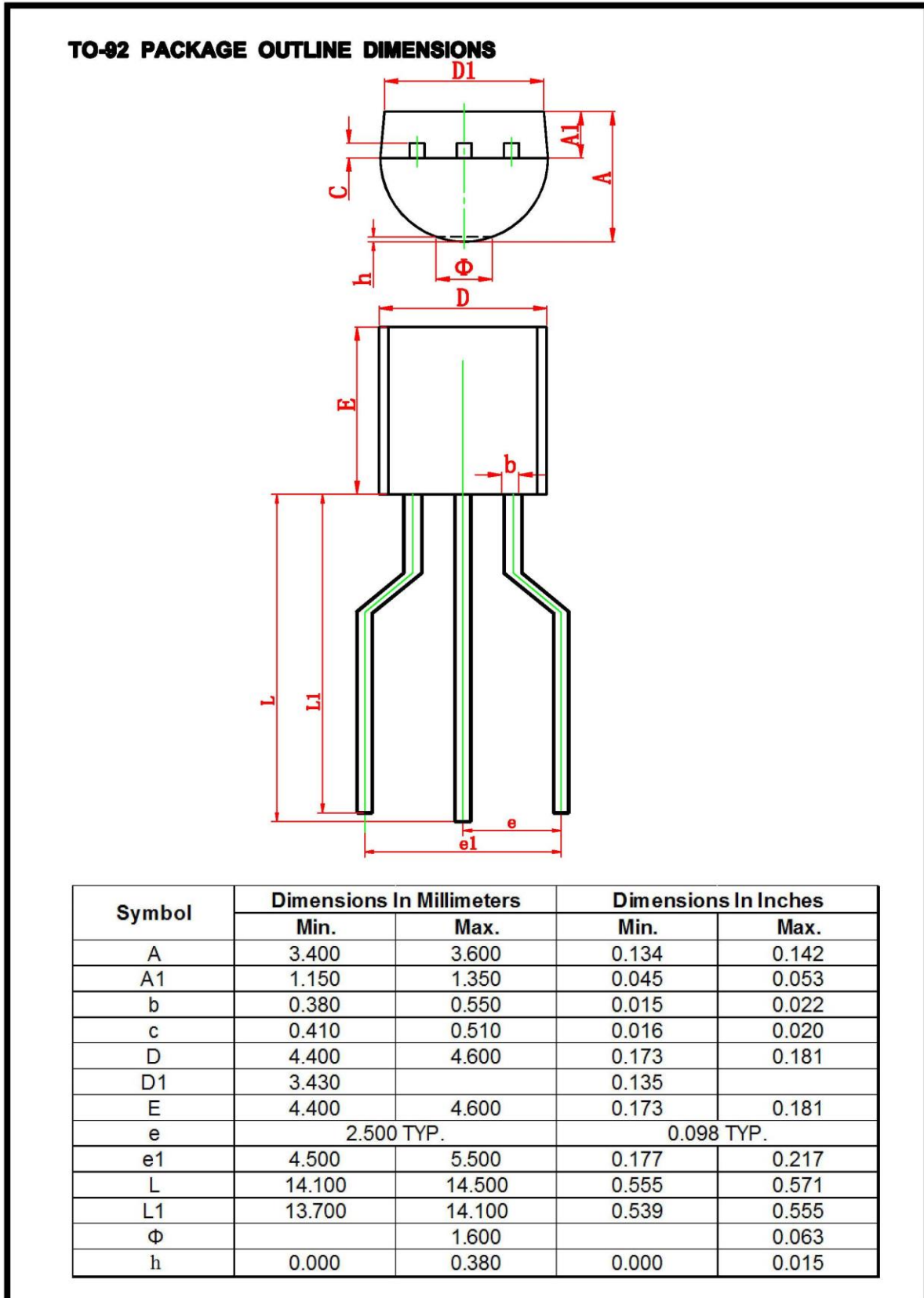

**Physical Dimensions (Shaped without tape)**

**Physical Dimensions (Shaped in Tape)**
