

BQR2V Series FPGA

Part Number: BQR2V6000

Page of Revise Control

Version No.	Publish Time	Revised Chapter	Revise Introduction	Note
1.0	2017.11		Initial release.	
1.1	2018.3		Update format	
1.2	2018.3		Package	

TABLE OF CONTENTS

1. Features	5
2. General Description.....	6
3. Architecture.....	7
3.1 Overview.....	7
3.2 Features.....	8
3.3 Combinations and Maximum Number of Available I/Os.....	51
4. Configuration.....	51
4.1 Configuration Modes	52
4.2 Slave-Serial Mode.....	52
4.3 Master-Serial Mode	52
4.4 Slave SelectMAP Mode.....	53
4.5 Master SelectMAP Mode.....	53
4.6 Boundary-Scan (JTAG, IEEE 1532) Mode	53
4.7 Configuration Sequence.....	54
4.8 Readback.....	55
4.9 Bitstream Encryption	55
4.10 Partial Reconfiguration	56
5. Electrical Characteristics	56
5.1 DC Characteristics	56
5.2 Power-On Power Supply Requirements	58
5.3 General Power Supply Requirements	59
5.4 DC Input and Output Levels	59
5.5 LDT Differential Signal DC Specifications (LDT_25)	60
5.6 LVDS DC Specifications (LVDS_33 and LVDS_25).....	60
5.7 Extended LVDS DC Specifications (LVDSEXT_33 and LVDSEXT_25)...	61

5.8	LVPECL DC Specifications	61
6.	<i>Pin Definitions</i>	62
7.	<i>Pinout Information and Package</i>	65
	<i>Appendix I Electrical performance characteristics</i>	78
	<i>Appendix II Application Notes</i>	85
	<i>Appendix III BitGen and PROMGen Switches and Options</i>	86

1. Features

- 0.13 μm 8-layer epitaxial process
- Certified to CAST C
- Guaranteed over the full military temperature range(-55°C to $+125^{\circ}\text{C}$)
- Radiation hardened FPGAs for space and satellite Applications
- Guaranteed total ionizing dose to 100K Rad(si)
- Latch-up immune to LET = 75 MeV cm^2/mg
- IP-Immersion Architecture
 - ◇ Densities 3M system gates
 - ◇ 300+ MHz internal clock speed (Advance Data)
 - ◇ 622+ Mb/s I/O(Advance Data)
- SelectRAM™ Memory Hierarchy
 - ◇ 2.592Mb of dual-port RAM in 18 Kbit block SelectRAM resources
 - ◇ 1.056Mb of distributed SelectRAM resources
- High-Performance Interfaces to External Memory
 - ◇ SRAM interfaces
 - SDR/DDR SRAM
 - QDR SRAM
 - ◇ CAM interfaces
- Arithmetic Functions
 - ◇ Dedicated 18-bit \times 18-bit multiplier blocks
- ◇ Fast look-ahead carry logic chains
- Flexible Logic Resources
 - ◇ Up to 67584 internal registers/latches with Clock Enable
 - ◇ Up to 67584 look-up tables (LUTs) or cascadable 16-bit shift registers
 - ◇ Wide multiplexers and wide-input function support
 - ◇ Horizontal cascade chain and sum-of-products support
 - ◇ Internal 3-state busing
- High-Performance Clock Management Circuitry
 - ◇ Up to 12 DCM (Digital Clock Manager) modules
 - Precise clock de-skew
 - Flexible frequency synthesis
 - High-resolution phase shifting
 - ◇ 16 global clock multiplexer buffers
- Active Interconnect Technology
 - ◇ Fourth generation segmented routing structure
 - ◇ Predictable, fast routing delay, independent of fanout

- **SelectIO™-Ultra Technology**
 - ✧ Up to 824 user I/Os
 - ✧ 19 single-ended and six differential standards
 - ✧ Programmable sink current (2 mA to 24 mA) per I/O
 - ✧ Digitally Controlled Impedance (DCI) I/O: on-chip termination resistors for single-ended I/O standards
 - ✧ Differential Signaling
 - 622 Mb/s Low-Voltage Differential Signaling I/O (LVDS) with current mode drivers
 - Bus LVDS I/O
 - Lightning Data Transport (LDT) I/O with current driver buffers
 - Low-Voltage Positive Emitter-Coupled Logic (LVPECL) I/O
 - Built-in DDR input and
- output registers
 - ✧ Proprietary high-performance SelectLink Technology
 - High-bandwidth data path
 - Double Data Rate (DDR) link
 - Web-based HDL generation methodology
- Supported by Xilinx ISE Development Systems
- SRAM-Based In-System Configuration
 - ✧ Fast SelectMAP configuration
 - ✧ IEEE 1532 support
 - ✧ Partial reconfiguration
 - ✧ Unlimited reprogrammability
 - ✧ Readback capability
- 1.5V (V_{CCINT}) Core Power Supply, Dedicated 3.3V V_{CCAUX} Auxiliary and V_{CCO} I/O Power Supplies IEEE 1149.1 Compatible Boundary-Scan Logic Support

2. General Description

The BQR2V6000 is developed for high performance, high-density, aerospace designs that are based on IP cores and customized modules. The device delivers complete solutions for telecommunication, networking, video, and DSP applications, including PCI, LVDS, and DDR interfaces.

The 0.13 μm CMOS 8-layer metal process and the BQR2V6000 architecture are optimized for high speed with low power consumption. Combining a wide variety of flexible features and a high densities of 1 million system gates, the BQR2V6000 enhances programmable logic design capabilities and is a powerful alternative to

mask-programmed gates arrays and other one-time-programmable device. As shown in Table 1, the BQR2V6000 comprises CLB, Multiplier Blocks, SelectRAM Blocks, DCMs and IOBs.

Table 1: BQR2V6000-CCGA1144 Field-Programmable Gate Array

Device	System Gates	CLB (1 CLB = 4 slices = Max 128 bits)			Multiplier Blocks	SelectRAM Blocks		DCMs	Max I/O Pads
		Array	Slices	Maximum Distributed RAM Kbits		18 Kbit	Max RAM		
		Row xCol.				Blocks	(Kbits)		
BQR2V6000	6M	96 x 88	33,792	1,056	144	144	2,592	12	824

3. Architecture

3.1 Overview

BQR2V6000 device are user-programmable gate arrays with various configurable elements. The BQR2V6000 architecture is optimized for high-density and high-performance logic designs. As shown in Figure 1, the programmable device is comprised of input/output blocks (IOBs) and internal configurable logic blocks (CLBs).

Programmable I/O blocks provide the interface between package pins and the internal configurable logic. Most popular and leading-edge I/O standards are supported by the programmable IOBs.

The internal configurable logic includes four major elements organized in a regular array:

- Configurable Logic Blocks (CLBs) provide functional elements for combinatorial and synchronous logic, including basic storage elements. BUFTs (3-state buffers) associated with each CLB element drive dedicated segmentable horizontal routing resources.
- Block SelectRAM memory modules provide large 18 Kbit storage elements of dual-port RAM.
- Multiplier blocks are 18-bit×18-bit dedicated multipliers.
- DCM (Digital Clock Manager) blocks provide self-calibrating, fully digital solutions for clock distribution delay compensation, clock multiplication and division, coarse- and fine-grained clock phase shifting.

A new generation of programmable routing resources called Active Interconnect Technology interconnects all of these elements. The general routing matrix (GRM) is

an array of routing switches. Each programmable element is tied to a switch matrix, allowing multiple connections to the general routing matrix. The overall programmable interconnection is hierarchical and designed to support high-speed designs.

All programmable elements, including the routing resources, are controlled by values stored in static memory cells. These values are loaded in the memory cells during configuration and can be reloaded to change the functions of the programmable elements.

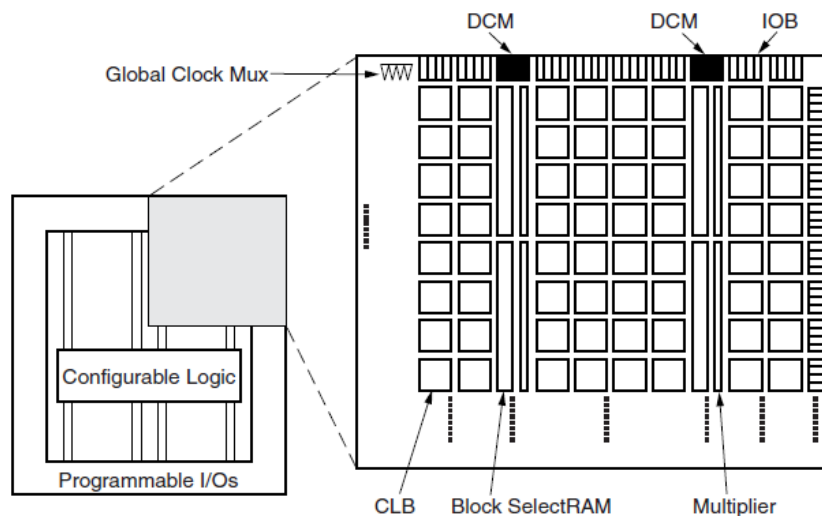

Figure 1 BQR2V6000 Architecture Overview

3.2 Features

This section briefly describes BQR2V6000 features.

3.2.1 Input/Output Blocks (IOBs)

BQR2V6000 I/O blocks (IOBs) are provided in groups of two or four on the perimeter of each device. Each IOB can be used as an input and/or an output for single-ended I/Os. Two IOBs can be used as a differential pair. A differential pair is always connected to the same switch matrix, as shown in Figure 2.

Note: Differential I/Os must use the same clock.

IOB blocks are designed for high-performance I/Os, supporting 19 single-ended standards, as well as differential signaling with LVDS, LDT, Bus LVDS, and LVPECL.

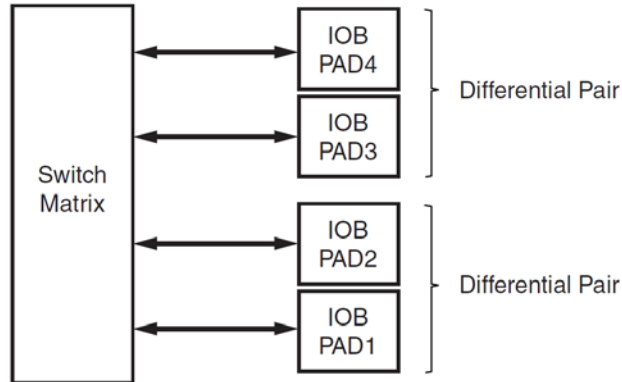

Figure 2 BQR2V6000 Input/Output Tile

Supported I/O Standards

BQR2V6000 IOB blocks feature SelectI/O-Ultra inputs and outputs that support a wide variety of I/O signaling standards. In addition to the internal supply voltage ($V_{CCINT} = 1.5V$), output driver supply voltage (V_{CCO}) is dependent on the I/O standard (see Table 2). An auxiliary supply voltage ($V_{CCAUX} = 3.3 V$) is required, regardless of the I/O standard used.

Table 1 Supported Single-Ended I/O Standards

I/O Standard	Output V_{CCO}	Input V_{CCO}	Input V_{REF}	Board Termination Voltage (V_{TT})
LVTTL	3.3	3.3	N/A	N/A
LVC MOS33	3.3	3.3	N/A	N/A
LVC MOS25	2.5	2.5	N/A	N/A
LVC MOS18	1.8	1.8	N/A	N/A
LVC MOS15	1.5	1.5	N/A	N/A
PCI33_3	3.3	3.3	N/A	N/A
PCI66_3	3.3	3.3	N/A	N/A
PCI-X	3.3	3.3	N/A	N/A
GTL	Note 1	Note 1	0.8	1.2
GTL P	Note 1	Note 1	1.0	1.5
HSTL_I	1.5	N/A	0.75	0.75
HSTL_II	1.5	N/A	0.75	0.75
HSTL_III	1.5	N/A	0.9	1.5
HSTL_IV	1.5	N/A	0.9	1.5
HSTL_I_18	1.8	N/A	0.9	0.9

I/O Standard	Output V _{CCO}	Input V _{CCO}	Input V _{REF}	Board Termination Voltage(V _{TT})
HSTL_II_18	1.8	N/A	0.9	0.9
HSTL_III_18	1.8	N/A	1.1	1.8
HSTL_IV_18	1.8	N/A	1.1	1.8
SSTL2_I	2.5	N/A	1.25	1.25
SSTL2_II	2.5	N/A	1.25	1.25
SSTL3_I	3.3	N/A	1.5	1.5
SSTL3_II	3.3	N/A	1.5	1.5
AGP-2X/AGP	3.3	N/A	1.32	N/A

Notes:

1. V_{CCO} of GTL or GTLP should not be lower than the termination voltage or the voltage seen at the I/O pad.

Table 2 Supported Differential Signal I/O Standards

I/O Standard	Output V _{CCO}	Input V _{CCO}	Input V _{REF}	Output V _{OD}
LVPECL_33	3.3	N/A	N/A	490mV to 1.22V
LDT_25	2.5	N/A	N/A	0.430-0.670
LVDS_33	3.3	N/A	N/A	0.250-0.400
LVDS_25	2.5	N/A	N/A	0.250-0.400
LVDSEXT_33	3.3	N/A	N/A	0.330-0.700
LVDSEXT_25	2.5	N/A	N/A	0.330-0.700
BLVDS_25	2.5	N/A	N/A	0.250-0.450
ULVDS_25	2.5	N/A	N/A	0.430-0.670

All of the user IOBs have fixed-clamp diodes to V_{CCO} and to ground. These IOBs are not 5V tolerant.

Logic Resources

IOB blocks include six storage elements, as shown in Figure 3. Each storage element can be configured either as an edge-triggered D-type flip-flop or as a level-sensitive latch. On the input, output, and 3-state path, one or two DDR registers can be used.

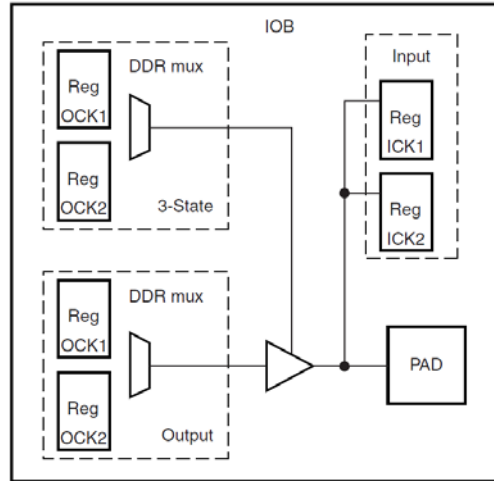

Figure 3 BQR2V6000 IOB Block

Double data rate is directly accomplished by the two registers on each path, clocked by the rising edges (or falling edges) from two different clock nets. The two clock signals are generated by the DCM and must be 180 degrees out of phase, as shown in Figure 4. There are two input, output, and 3-state data signals, each being alternately clocked out.

The DDR mechanism shown in Figure 4 can be used to mirror a copy of the clock on the output. This is useful for propagating a clock along the data that has an identical delay. It is also useful for multiple clock generation, where there is a unique clock driver for every clock load. BQR2V6000 can produce many copies of a clock with very little skew.

Each group of two registers has a clock enable signal (ICE for the input registers, OCE for the output registers, and TCE for the 3-state registers). The clock enable signals are active High by default. If left unconnected, the clock enable for that storage element defaults to the active state.

Each IOB block has common synchronous or asynchronous set and reset (SR and REV signals). SR forces the storage element into the state specified by the SRHIGH or SRLOW attribute. SRHIGH forces a logic "1". SRLOW forces a logic "0". When SR is used, a second input (REV) forces the storage element into the opposite state. The reset condition predominates over the set condition. The initial state after configuration or global initialization state is defined by a separate INIT0 and INIT1 attribute. By default, the SRLOW attribute forces INIT0, and the SRHIGH attribute forces INIT1.

For each storage element, the SRHIGH, SRLOW, INIT0, and INIT1 attributes are independent. Synchronous or asynchronous set/reset is consistent in an IOB block. All

the control signals have independent polarities. Any inverter placed on a control input is automatically absorbed.

Each register or latch (independent of all other registers or latches) (see Figure 5) can be configured as follows:

- No set or reset
- Synchronous set
- Synchronous reset
- Synchronous set and reset
- Asynchronous set (preset)
- Asynchronous reset (clear)
- Asynchronous set and reset (preset and clear)

The synchronous reset overrides a set, and an asynchronous clear overrides a preset.

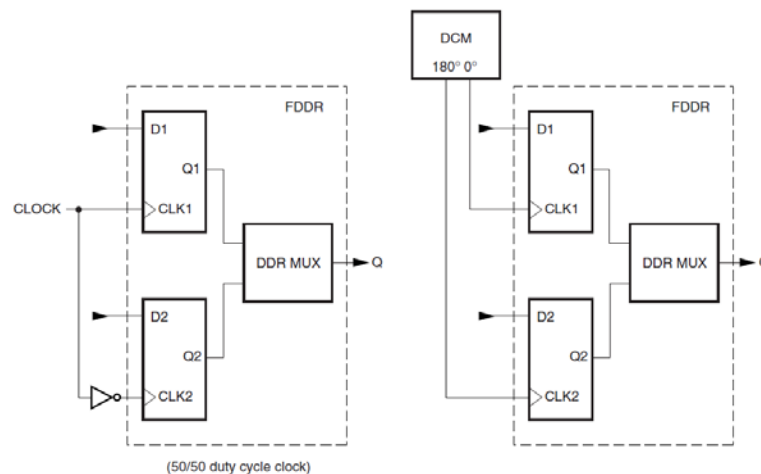

Figure 4 Double Data Rate Registers

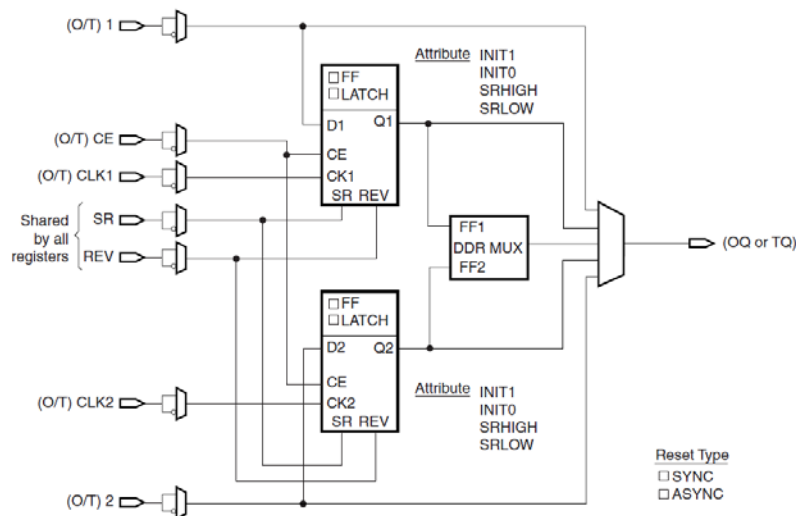

Figure 5 Register/Latch Configuration in an IOB Block

Input Path

The BQR2V6000 IOB input path routes input signals directly to internal logic and/or through an optional input flip-flop or latch, or through the DDR input registers. An optional delay element at the D-input of the storage element eliminates pad-to-pad hold time. The delay is matched to the internal clock-distribution delay of the BQR2V6000 and when used, ensures that the pad-to-pad hold time is zero. Each input buffer can be configured to conform to any of the low-voltage signaling standards supported. In some of these standards the input buffer utilizes a user-supplied threshold voltage, V_{REF} . The need to supply V_{REF} imposes constraints on which standards can be used in the same bank.

Output Path

The output path includes a 3-state output buffer that drives the output signal onto the pad. The output and/or the 3-state signal can be routed to the buffer directly from the internal logic or through an output/3-state flip-flop or latch, or through the DDR output/3-state registers. Each output driver can be individually programmed for a wide range of low-voltage signaling standards. In most signaling standards, the output High voltage depends on an externally supplied V_{CCO} voltage. The need to supply V_{CCO} imposes constraints on which standards can be used in the same bank.

I/O Banking

Some of the I/O standards described above require V_{CCO} and V_{REF} voltages. These voltages are externally supplied and connected to device pins that serve groups of IOB blocks, called banks. Consequently, restrictions exist about which I/O standards can be combined within a given bank. Eight I/O banks result from dividing each edge of the FPGA into two banks, as shown in Figure 6. Each bank has multiple V_{CCO} pins, all of which must be connected to the same voltage. This voltage is determined by the output standards in use.

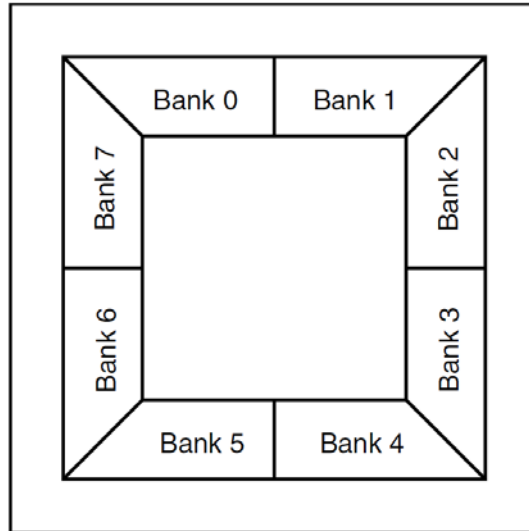

Figure 6 BQR2V6000 I/O Banks:Top View for Wire-Bond Package

Some input standards require a user-supplied threshold voltage (V_{REF}), and certain user-I/O pins are automatically configured as V_{REF} inputs. Approximately one in six of the I/O pins in the bank assume this role.

V_{REF} pins within a bank are interconnected internally, and consequently only one V_{REF} voltage can be used within each bank. However, for correct operation, all V_{REF} pins in the bank must be connected to the external reference voltage source.

Rules for Combining I/O Standards in the Same Bank

The following rules must be obeyed to combine different input, output, and bidirectional standards in the same bank:

1. Combining output standards only.

Output standards with the same output VCCO requirement can be combined in the same bank.

Compatible example:

SSTL2_I and LVDS_25_DCI outputs

Incompatible example:

SSTL2_I (output VCCO = 2.5V) and LVCMOS33 (output VCCO = 3.3V) outputs

2. Combining input standards only.

Input standards with the same input VCCO and input VREF requirements can be combined in the same bank.

Compatible example:

LVCMOS15 and HSTL_IV inputs

Incompatible example:

LVCMOS15 (input VCCO = 1.5V) and

LVCMOS18 (input VCCO = 1.8V) inputs

Incompatible example:

HSTL_I_DCI_18 (VREF = 0.9V) and

HSTL_IV_DCI_18 (VREF = 1.1V) inputs

3. Combining input standards and output standards.

Input standards and output standards with the same input VCCO and output VCCO requirement can be combined in the same bank.

Compatible example:

LVDS_25 output and HSTL_I input

Incompatible example:

LVDS_25 output (output VCCO = 2.5V) and

HSTL_I_DCI_18 input (input VCCO = 1.8V)

4. Combining bidirectional standards with input or output standards.

When combining bidirectional I/O with other standards, make sure the bidirectional standard can meet rules 1 through 3 above.

5. Additional rules for combining DCI I/O standards.

a. No more than one Single Termination type (input or output) is allowed in the same bank.

Incompatible example:

HSTL_IV_DCI input and HSTL_III_DCI input

b. No more than one Split Termination type (input or output) is allowed in the same bank.

Incompatible example:

HSTL_I_DCI input and HSTL_II_DCI input

Table 4 summarizes all standards and voltage supplies.

Table 3 Summary of Voltage Supply Requirements to All Input and Output Standards

I/O Standard	V _{CCO}		V _{REF}	Termination Type	
	Output	Input	Input	Output	Input
LVDS_33	3.3	N/R	N/R ⁽¹⁾	N/R	N/R

I/O Standard	V _{CCO}		V _{REF}	Termination Type	
	Output	Input	Input	Output	Input
LVDSEXT_33			N/R	N/R	N/R
LVPECL_33			N/R	N/R	N/R
SSTL3_I			1.5	N/R	N/R
SSTL3_II			1.5	N/R	N/R
AGP			1.32	N/R	N/R
LVTTTL			N/R	N/R	N/R
LVC MOS33			N/R	N/R	N/R
LVDCI_33			N/R	Series	N/R
LVDCI_DV2_33			N/R	Series	N/R
PCI33_3			N/R	N/R	N/R
PCI66_3			N/R	N/R	N/R
PCIX			N/R	N/R	N/R
LVDS_33_DCI			N/R	N/R	Split
LVDSEXT_33_DCI			N/R	N/R	Split
SSTL3_I_DCI			1.5	N/R	Split
SSTL3_II_DCI			1.5	Split	Split
LVDS_25	2.5	N/R	N/R	N/R	N/R
LVDSEXT_25			N/R	N/R	N/R
LDT_25			N/R	N/R	N/R
ULVDS_25			N/R	N/R	N/R
BLVDS_25			N/R	N/R	N/R
SSTL2_I			1.25	N/R	N/R
SSTL2_II			1.25	N/R	N/R
LVC MOS25			N/R	N/R	N/R
LVDCI_25			N/R	Series	N/R
LVDCI_DV2_25			N/R	Series	N/R
LVDS_25_DCI			N/R	N/R	Split
LVDSEXT_25_DCI			N/R	N/R	Split
SSTL2_I_DCI			1.25	N/R	Split
SSTL2_II_DCI			1.25	Split	Split
HSTL_III_18	1.8	N/R	1.1	N/R	N/R
HSTL_IV_18			1.1	N/R	N/R

I/O Standard	V _{CCO}		V _{REF}	Termination Type				
	Output	Input	Input	Output	Input			
HSTL_I_18			0.9	N/R	N/R			
HSTL_II_18			0.9	N/R	N/R			
SSTL18_I			0.9	N/R	N/R			
SSTL18_II			0.9	N/R	N/R			
LVC MOS18		1.8		N/R	N/R	N/R		
LVDCI_18				N/R	Series	N/R		
LVDCI_DV2_18				N/R	Series	N/R		
HSTL_III_DCI_18				1.1	N/R	Single		
HSTL_IV_DCI_18				1.1	Single	Single		
HSTL_I_DCI_18				0.9	N/R	Split		
HSTL_II_DCI_18				0.9	Split	Split		
SSTL18_I_DCI				0.9	N/R	Split		
SSTL18_II_DCI				0.9	Split	Split		
HSTL_III				1.5	N/R	0.9	N/R	N/R
HSTL_IV	0.9	N/R	N/R					
HSTL_I	0.75	N/R	N/R					
HSTL_II	0.75	N/R	N/R					
LVC MOS15	1.5		N/R		N/R	N/R		
LVDCI_15			N/R		Series	N/R		
LVDCI_DV2_15			N/R		Series	N/R		
GTLP_DCI			1		Single	Single		
HSTL_III_DCI			0.9		N/R	Single		
HSTL_IV_DCI			0.9		Single	Single		
HSTL_I_DCI			0.75		N/R	Split		
HSTL_II_DCI			0.75		Split	Split		
GTLP_DCI			1.2		1.2	0.8	Single	Single
GTLP			N/R		N/R	1	N/R	N/R
GTL	0.8	N/R		N/R				

Notes: 1. N/R = no requirement.

Digitally Controlled Impedance (DCI)

Today's chip output signals with fast edge rates require termination to prevent

reflections and maintain signal integrity. High pin count packages (especially ball gridarrays) can not accommodate external termination resistors.

DCI provides controlled impedance drivers and on-chip termination for single-ended and differential I/Os. This eliminates the need for external resistors, and improves signal integrity. The DCI feature can be used on any IOB by selecting one of the DCI I/O standards. When applied to inputs, DCI provides input parallel termination. When applied to outputs, DCI provides controlled impedance drivers (series termination) or output parallel termination. DCI operates independently on each I/O bank. When a DCI I/O standard is used in a particular I/O bank, external reference resistors must be connected to two dual-function pins on the bank. These resistors, the voltage reference of the N transistor (VRN), and the voltage reference of the P transistor (VRP) are shown in Figure 7.

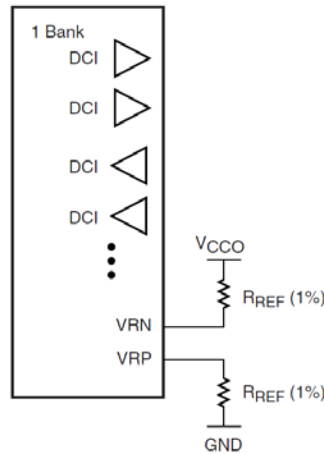

Figure 7 DCI in a BQR2V6000 Bank

When used with a terminated I/O standard, the value of resistors are specified by the standard (typically 50 Ω). When used with a controlled impedance driver, the resistors set the output impedance of the driver within the specified range (25 Ω to 100 Ω). For all series and parallel terminations listed in Table 5 and Table 6, the reference resistors must have the same value for any given bank. One percent resistors are recommended. The DCI system adjusts the I/O impedance to match the two external reference resistors or half of the reference resistors, and compensates for impedance changes due to voltage and/or temperature fluctuations. The adjustment is done by turning parallel transistors in the IOB on or off.

Table 4 Select I/O-Ultra Controlled Impedance Buffers

V_{CC0}	DCI	DCI Half Impedance
3.3V	LVDCI_33	LVDCI_DV2_33
2.5V	LVDCI_25	LVDCI_DV2_25

1.8V	LVDCI_18	LVDCI_DV2_18
1.5V	LVDCI_15	LVDCI_DV2_15

Controlled Impedance Drives(Series Termination)

DCI can be used to provide a buffer with a controlled output impedance. It is desirable for this output impedance to match the transmission line impedance (Z). BQR2V6000 input buffers also support LVDCI and LVDCI_DV2 I/O standards.

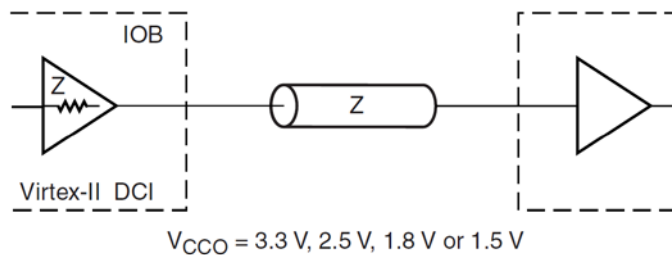

Figure 8 Internal Series Termination

Controlled Impedance Drives(Parallel Termination)

DCI also provides on-chip termination for SSTL3, SSTL2, HSTL (Class I, II, III, or IV), and GTL/GTLP receivers or transmitters on bidirectional lines.

Table 6 lists the on-chip parallel terminations available in BQR2V6000. V_{CCO} must be set according to Table 7. Note that there is a V_{CCO} requirement for GTL_DCI and GTLP_DCI, due to the on-chip termination resistor.

Table 5 Select I/O-Ultra Controlled Impedance Buffers

I/O Standard	External Termination	On-Chip Termination
SSTL3 Class I	SSTL3_I	SSTL3_I_DCI ⁽¹⁾
SSTL3 Class II	SSTL3_II	SSTL3_II_DCI ⁽¹⁾
SSTL2 Class I	SSTL2_I	SSTL2_I_DCI ⁽¹⁾
SSTL2 Class II	SSTL2_II	SSTL2_II_DCI ⁽¹⁾
HSTL Class I	HSTL_I	HSTL_I_DC
HSTL Class II	HSTL_II	HSTL_II_DC
HSTL Class III	HSTL_III	HSTL_III_DC
HSTL Class IV	HSTL_IV	HSTL_IV_DC
GTL	GTL	GTL_DC
GTLP	GTLP	GTLP_DC

Table 6 Supported DCI I/O Standards

I/O Standard	Output VCCO	Input VCCO	Input VREF	Termination Type
LVDCI_33 ⁽¹⁾	3.3	3.3	N/A	Series
LVDCI_DV2_33 ⁽¹⁾	3.3	3.3	N/A	Series
LVDCI_25 ⁽¹⁾	2.5	2.5	N/A	Series
LVDCI_DV2_25 ⁽¹⁾	2.5	2.5	N/A	Series
LVDCI_18 ⁽¹⁾	1.8	1.8	N/A	Series
LVDCI_DV2_18 ⁽¹⁾	1.8	1.8	N/A	Series
LVDCI_15 ⁽¹⁾	1.5	1.5	N/A	Series
LVDCI_DV2_15 ⁽¹⁾	1.5	1.5	N/A	Series
GTL_DCI	1.2	1.2	0.8	Single
GTL_P_DCI	1.5	1.5	1.0	Single
HSTL_I_DCI	1.5	1.5	0.75	Split
HSTL_II_DCI	1.5	1.5	0.75	Split
HSTL_III_DCI	1.5	1.5	0.9	Single
HSTL_IV_DCI	1.5	1.5	0.9	Single
HSTL_I_DCI	1.8	N/A	0.9	Split
HSTL_II_DCI	1.8	N/A	0.9	Split
HSTL_III_DCI	1.8	N/A	1.1	Single
HSTL_IV_DCI	1.8	N/A	1.1	Single
SSTL2_I_DCI ⁽²⁾	2.5	2.5	1.25	Split
SSTL2_II_DCI ⁽²⁾	2.5	2.5	1.25	Split
SSTL3_I_DCI ⁽²⁾	3.3	3.3	1.5	Split
SSTL3_II_DCI ⁽²⁾	3.3	3.3	1.5	Split

Notes:

1. LVDCI_XX and LVDCI_DV2_XX are LVCMOS controlled impedance buffers, matching the reference resistors or half of the reference resistors.
2. These are SSTL compatible.

3.2.2 Configurable Logic Blocks (CLBs)

BQR2V6000 configurable logic blocks (CLB) are organized in an array and are used to build combinatorial and synchronous logic designs. Each CLB element is tied

to a switch matrix to access the general routing matrix, as shown Figure 9. A CLB element comprises four similar slices with fast local feedback within the CLB. The four slices are split into two columns of two slices with two independent carry logic chains and one common shift chain.

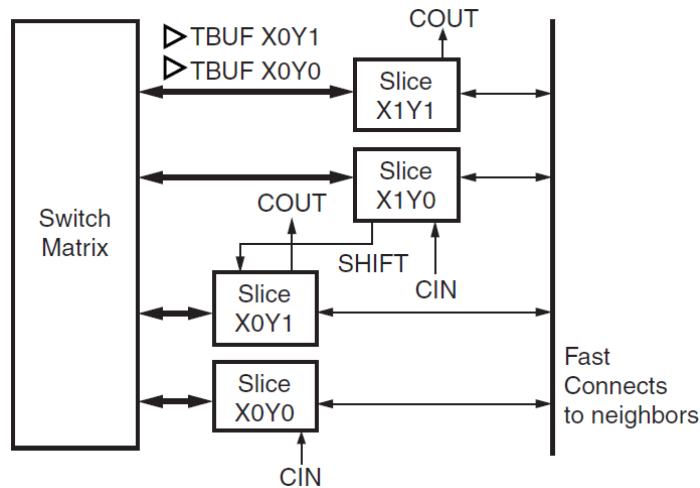

Figure 9 BQR2V6000 CLB Element

Slice Description

Each slice includes two 4-input function generators, carry logic, arithmetic logic gates, wide function multiplexers and two storage elements. As shown in Figure 10, each 4-input function generator is programmable as a 4-input LUT, 16 bits of distributed SelectRAM memory, or a 16-bit variable-tap shift register element.

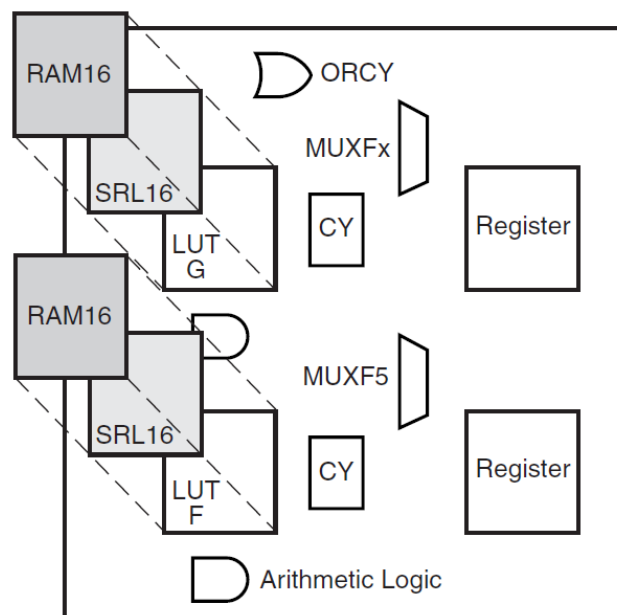

Figure 10 BQR2V6000 Slice Configuration

The output from the function generator in each slice drives both the slice output

and the D input of the storage element. Figure 11 shows a more detailed view of a single slice.

Look-Up Table

BQR2V6000 function generators are implemented as 4-input look-up tables (LUTs). Four independent inputs are provided to each of the two function generators in a slice (F and G). These function generators are each capable of implementing any arbitrarily defined Boolean function of four inputs. The propagation delay is therefore independent of the function implemented. Signals from the function generators can exit the slice (X or Y output), can input the XOR dedicated gate (see arithmetic logic), or input the carry-logic multiplexer (see fast look-ahead carry logic), or feed the D input of the storage element, or go to the MUXF5 (not shown in Figure 11). In addition to the basic LUTs, the BQR2V6000 slice contains logic (MUXF5 and MUXFX multiplexers) that combines function generators to provide any function of five, six, seven, or eight inputs. The MUXFXs are either MUXF6, MUXF7, or MUXF8 according to the slice considered in the CLB. Selected functions up to nine inputs (MUXF5 multiplexer) can be implemented in one slice. The MUXFX can also be a MUXF6, MUXF7, or MUXF8 multiplexer to map any functions of six, seven, or eight inputs and selected wide logic functions.

Register/Latch

The storage elements in a BQR2V6000 slice can be configured as either edge-triggered D-type flip-flops or level-sensitive latches. The D input can be directly driven by the X or Y output via the DX or DY input, or by the slice inputs bypassing the function generators via the BX or BY input. The clock enable signal (CE) is active High by default. If left unconnected, the clock enable for that storage element defaults to the active state. In addition to clock (CK) and clock enable (CE) signals, each slice has set and reset signals (SR and BY slice inputs). SR forces the storage element into the state specified by the attribute SRHIGH or SRLOW. SRHIGH forces a logic “1” when SR is asserted. SRLOW forces a logic “0”. When SR is used, a second input (BY) forces the storage element into the opposite state. The reset condition is predominant over the set condition (Figure 12). The initial state after configuration or global initial state is defined by a separate INIT0 and INIT1 attribute. By default, setting the SRLOW attribute sets INIT0, and setting the SRHIGH attribute sets INIT1.

For each slice, set and reset can be set to be synchronous or asynchronous. BQR2V6000 also have the ability to set INIT0 and INIT1 independent of SRHIGH and SRL0W. Control signals CLK, CE, and SR are common to both storage elements in one slice. All control signals have independent polarities. Any inverter placed on a control input is automatically absorbed. The set and reset functionality of a register or a latch can be configured as follows:

- No set or reset
- Synchronous set
- Synchronous reset
- Synchronous set and reset
- Asynchronous set (preset)
- Asynchronous reset (clear)
- Asynchronous set and reset (preset and clear)

The synchronous reset has precedence over a set, and an asynchronous clear has precedence over a preset.

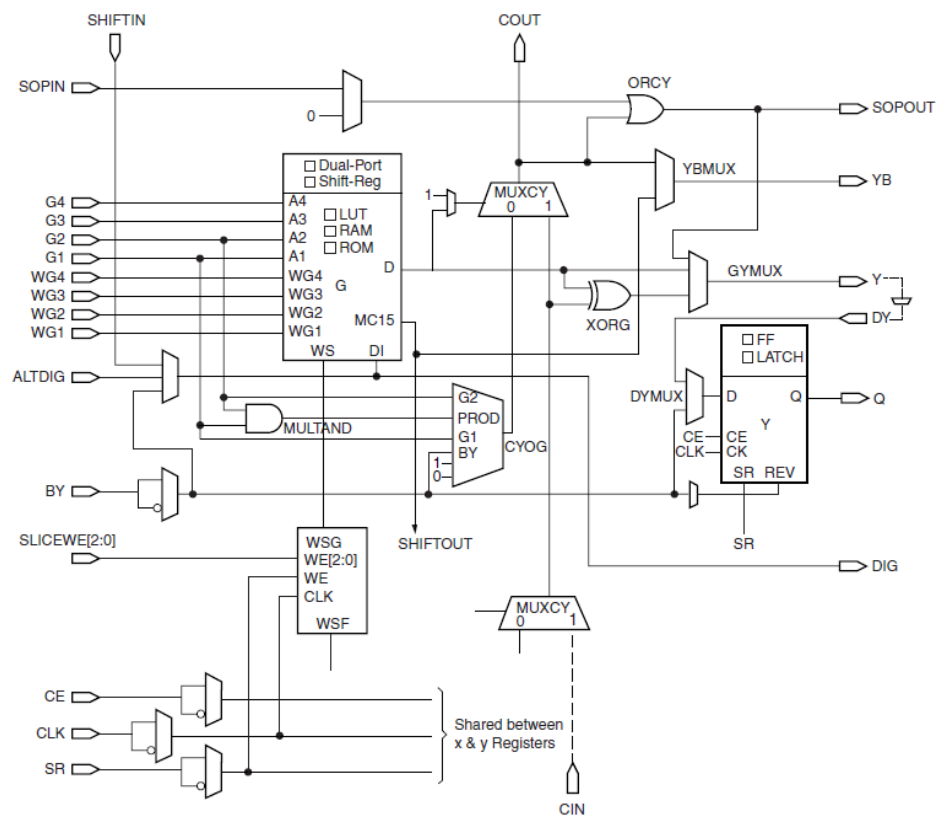

Figure 11 BQR2V6000 Slice(Top Half)

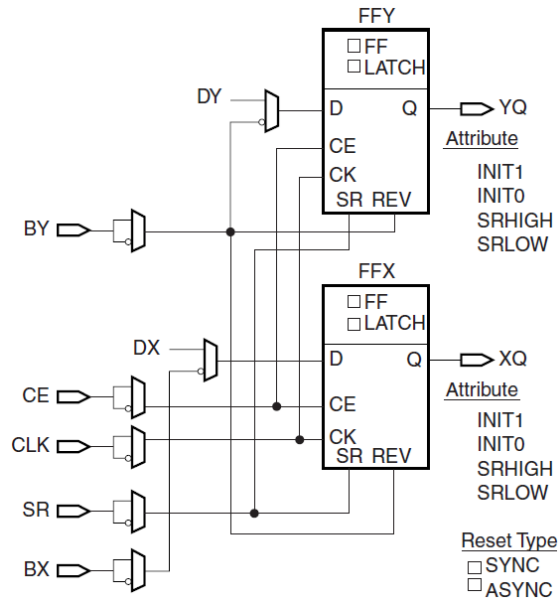

Figure 12 Register/Latch Configuration in a Slice

Distributed SelectRAM Memory

Each function generator (LUT) can implement a 16 x 1-bit synchronous RAM resource called a distributed SelectRAM element. The SelectRAM elements are configurable within a CLB to implement the following:

- Single-Port 16 x 8 bit RAM
- Single-Port 32 x 4 bit RAM
- Single-Port 64 x 2 bit RAM
- Single-Port 128 x 1 bit RAM
- Dual-Port 16 x 4 bit RAM
- Dual-Port 32 x 2 bit RAM
- Dual-Port 64 x 1 bit RAM

Distributed SelectRAM memory modules are synchronous(write) resources. The combinatorial read access time is extremely fast, while the synchronous write simplifies high-speed designs. A synchronous read can be implemented with a storage element in the same slice. The distributed SelectRAM memory and the storage element share the same clock input. A Write Enable (WE) input is active High, and is driven by the SR input. Table 8 shows the number of LUTs (2 per slice) occupied by each distributed SelectRAM configuration.

Table 7 Distributed SelectRAM Configurations

RAM	Number
16 x1S	1
16 x1D	2
32x1S	2
32x1D	4
64x1S	4
64x1D	8
128x1S	8

Notes:

1. S = single-port configuration, and D = dual-port configuration.

For single-port configurations, distributed SelectRAM memory has one address port for synchronous writes and asynchronous reads. For dual-port configurations, distributed SelectRAM memory has one port for synchronous writes and asynchronous reads and another port for asynchronous reads. The function generator (LUT) has separated read address inputs (A1, A2, A3, A4) and write address inputs (WG1/WF1, WG2/WF2, WG3/WF3, WG4/WF4). In single-port mode, read and write addresses share the same address bus. In dual-port mode, one function generator (R/W port) is connected with shared read and write addresses. The second function generator has the A inputs (read) connected to the second read-only port address and the W inputs (write) shared with the first read/write port address. Figure 13, Figure 14, and Figure 15 illustrate various example configurations

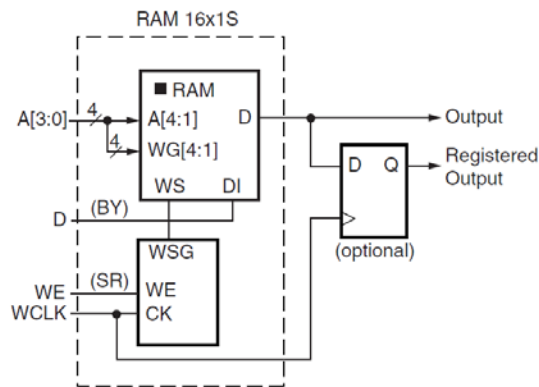

Figure 13 Distributed SelectRAM (RAM16x1S)

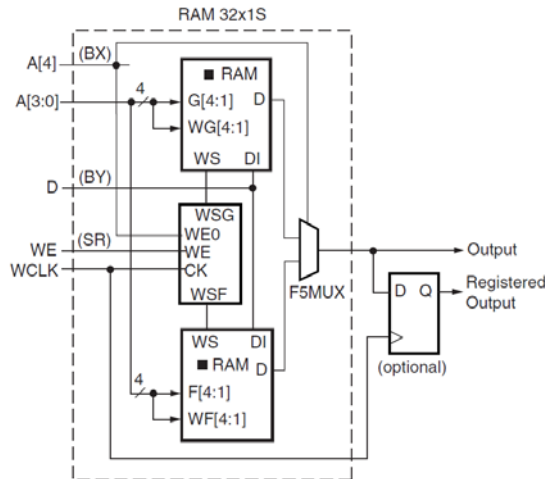

Figure 14 Single-Port Distributed SelectRAM(RAM32x1S)

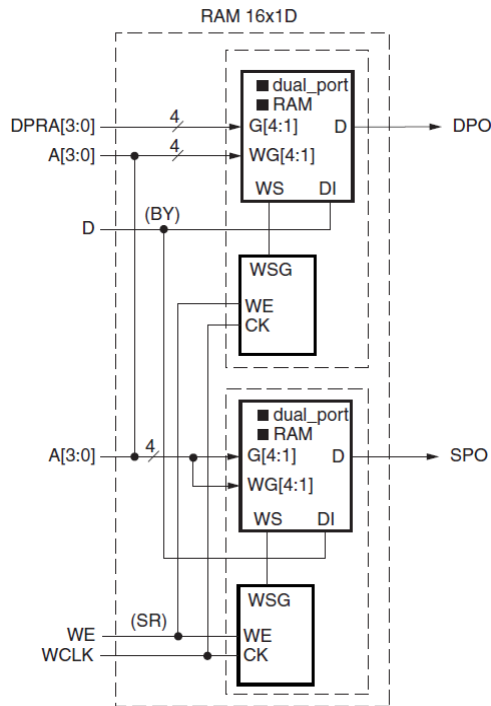

Figure 15 Dual-Port Distributed SelectRAM(RAM16x1D)

Similar to the RAM configuration, each function generator(LUT) can implement a 16 x 1-bit ROM. Five configurations are available: ROM16x1, ROM32x1, ROM64x1,ROM128x1, and ROM256x1. The ROM elements are cascadable to implement wider or/and deeper ROM.ROM contents are loaded at configuration. Table 9 shows the number of LUTs occupied by each configuration.

Table 8 ROM Configuration

ROM	Number of LUTs
16 x1	1

32x1	2
64x1	4
128x1	8(1CLB)
256 x1	16(2CLB)

Shift Registers

Each function generator can also be configured as a 16-bit shift register. The write operation is synchronous with a clock input (CLK) and an optional clock enable, as shown in Figure 16. A dynamic read access is performed through the 4-bit address bus, A[3:0]. The configurable 16-bit shift register cannot be set or reset. The read is asynchronous, however, the storage element or flip-flop is available to implement a synchronous read. The storage element should always be used with a constant address. For example, when building an 8-bit shift register and configuring the addresses to point to the seventh bit, the eighth bit can be the flip-flop. The overall system performance is improved by using the superior clock-to-out of the flip-flops.

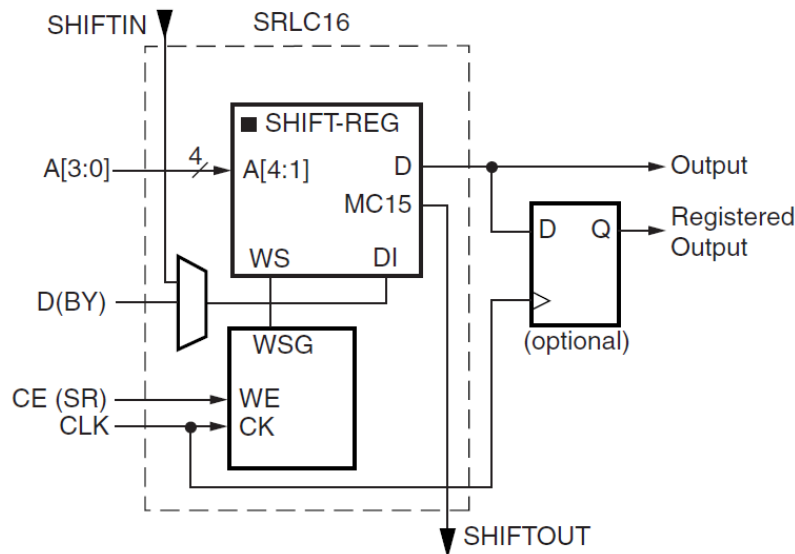

Figure 16 Shift Register Configurations

An additional dedicated connection between shift registers allows connecting the last bit of one shift register to the first bit of the next, without using the ordinary LUT output. Longer shift registers can be built with dynamic access to any bit in the chain. The shift register chaining and the MUXF5, MUXF6, and MUXF7 multiplexers allow up to a 128-bit shift register with addressable access to be implemented in one CLB.

Multiplexers

BQR2V6000 function generators and associated multiplexers can implement the following:

- 4:1 multiplexer in one slice
- 8:1 multiplexer in two slices
- 16:1 multiplexer in one CLB element (4 slices)
- 32:1 multiplexer in two CLB elements (8 slices)

Each slice has one MUXF5 multiplexer and one MUXFX multiplexer. The MUXFX multiplexer implements the MUXF6, MUXF7, or MUXF8, as shown in Figure 17. Each CLB element has two MUXF6 multiplexers, one MUXF7 multiplexer and one MUXF8 multiplexer. Any LUT can implement a 2:1 multiplexer.

Fast Lookahead Carry Logic

Dedicated carry logic provides fast arithmetic addition and subtraction. The BQR2V6000 CLB has two separate carry chains. The height of the carry chains is two bits per slice. The carry chain in the BQR2V6000 is running upward. The dedicated carry path and carry multiplexer (MUXCY) can also be used to cascade function generators for implementing wide logic functions.

Arithmetic Logic

The arithmetic logic includes an XOR gate that allows a 2-bit full adder to be implemented within a slice. In addition, a dedicated AND (MULT_AND) gate (shown in Figure 11) improves the efficiency of multiplier implementation.

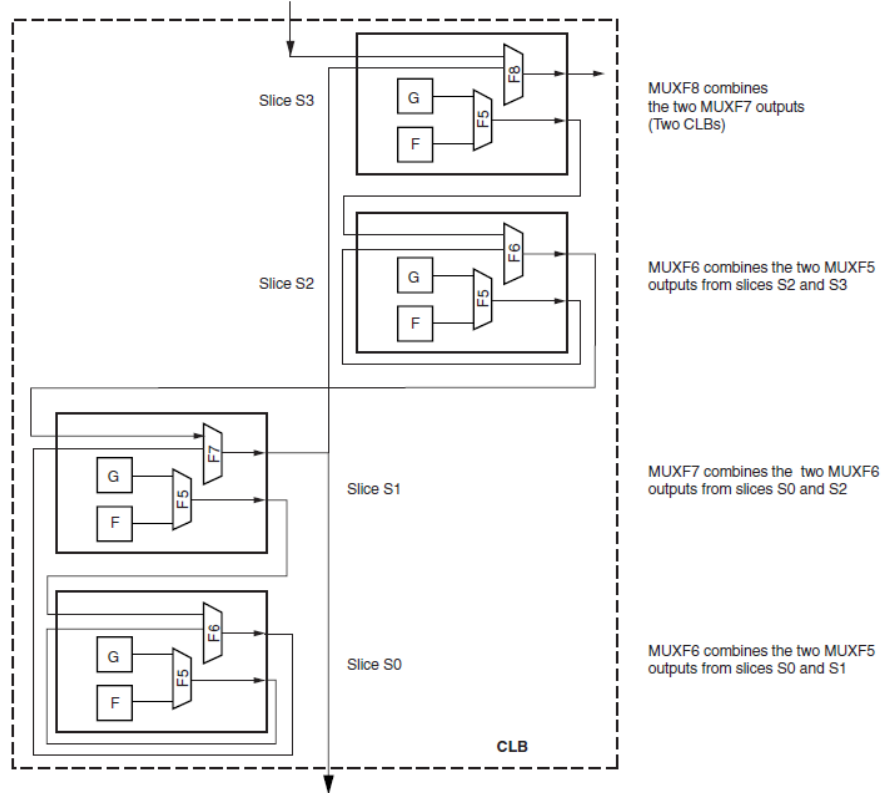

Figure 17 MUXF5 and MUXFX multiplexers

Sum of Products

Each slice has a dedicated OR gate named ORCY, ORing together outputs from the slices carryout and the ORCY from an adjacent slice. The ORCY gate with the dedicated Sum of Products (SOP) chain are designed for implementing large, flexible SOP chains. One input of each ORCY is connected through the fast SOP chain to the output of the previous ORCY in the same slice row. The second input is connected to the output of the top MUXCY in the same slice, as shown in Figure 18. LUTs and MUXCYs can implement large AND gates or other combinatorial logic functions. Figure 19 illustrates LUT and MUXCY resources configured as a 16-input AND gate.

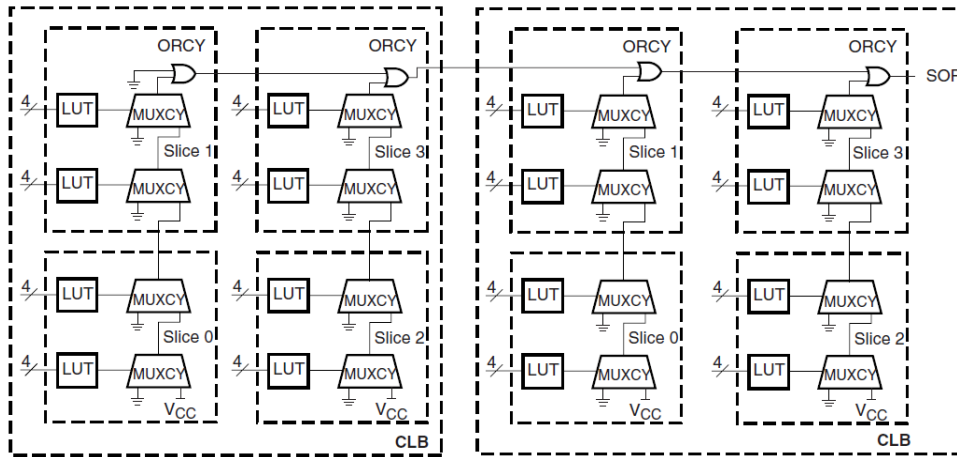

Figure 18 Horizontal Cascade Chain

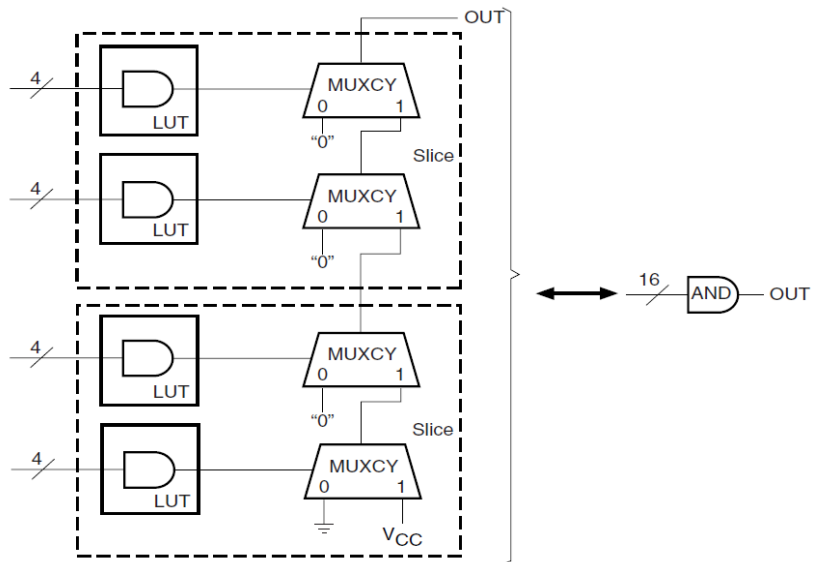

Figure 19 Wide-Input AND Gate(16Inputs)

3-State Buffers

Each CLB contains two 3-state drivers (TBUFs) that can drive on-chip buses. Each 3-state buffer has its own 3-state control pin and its own input pin. Each of the four slices have access to the two 3-state buffers through the switch matrix, as shown in Figure 20. TBUFs in neighboring CLBs can access slice outputs by direct connects. The outputs of the 3-state buffers drive horizontal routing resources used to implement 3-state buses.

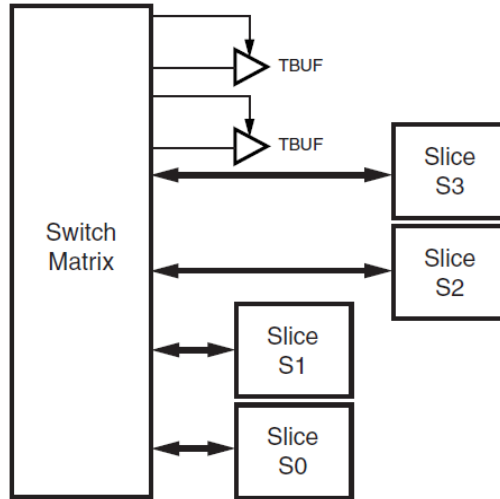

Figure 20 BQR2V6000 3-State Buffers

Four horizontal routing resources per CLB are provided for on-chip 3-state buses. Each 3-state buffer has access alternately to two horizontal lines, which can be partitioned as shown in Figure 21. The switch matrices corresponding to SelectRAM memory and multiplier or I/O blocks are skipped. Table 10 shows the number of 3-state buffers available in BQR2V6000.

Table 9 BQR2V6000 3-State Buffers

Device	3-State Buffers per Row	Total Number of 3-State Buffers
BQR2V6000	176	16,896

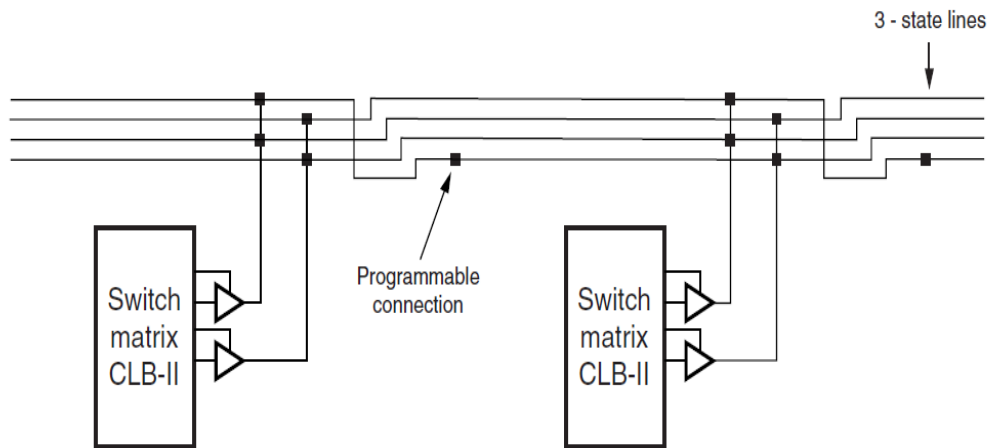

Figure 21 3-State Buffer Connection to Horizontal Lines

Table 11 summarizes the logic resources in one CLB. All of the CLBs are identical and each CLB or slice can be implemented in one of the configurations listed. Table 12 shows the available resources in all CLBs.

Table 10 Logic Resources in One CLB

Slices	LUTs	Flip-Flops	MULT_ANDs	Arithmetic & Carry Chains	SOP Chains	Distributed SelectRAM	Shift Registers	TBUF
4	8	8	8	2	2	128bits	128bits	2

Table 11 BQR2V6000 Logic Resource Available In All CLBs

Device	CLB Array: Row x Column	Number of Slices	Number of LUTs	Max Distributed SelectRAM or Shift Register (bits)	Number of Flip-Flops	Number of Carry Chains ⁽¹⁾	Number of SOP Chains ⁽¹⁾
BQR2V6000	96 x 88	33,792	67,584	1,081,344	67,584	176	192

Notes:

1. The carry chains and SOP chains can be split or cascaded.

3.2.3 Block SelectRAM Memory

BQR2V6000 incorporate large amounts of 18 Kbit block SelectRAM. These complement the distributed SelectRAM resources that provide shallow RAM structures implemented in CLBs. Each BQR2V6000 block SelectRAM is an 18 Kbit true dual-port RAM with two independently clocked and independently controlled synchronous ports that access a common storage area. Both ports are functionally identical. CLK, EN, WE, and SSR polarities are defined through configuration. Each port has the following types of inputs: Clock and Clock Enable, Write Enable, Set/Reset, and Address, as well as separate Data/parity data inputs (for writes) and Data/parity data outputs (for reads). Operation is synchronous. The block SelectRAM behaves like a register. Control, address, and data inputs must (and need only) be valid during the set-up time window prior to a rising (or falling, a configuration option) clock edge. Data outputs change as a result of the same clock edge.

The BQR2V6000 block SelectRAM supports various configurations, including single- and dual-port RAM and various data/address aspect ratios. Supported memory configurations for single- and dual-port modes are shown in Table 13

Table 12 Dual- and Single-Port Configurations

16Kx1 bit	2Kx9bits
8Kx2bits	1Kx18bits

Single-Port Configuration

As a single-port RAM, the block SelectRAM has access to the 18 Kbit memory locations in any of the 2K x 9-bit, 1K x 18-bit, or 512 x 36-bit configurations and to 16 Kbit memory locations in any of the 16K x 1-bit, 8K x 2-bit, or 4K x 4-bit configurations. The advantage of 9-bit, 18-bit, and 36-bit widths is the ability to store a parity bit for every eight bits. Parity bits must be generated or checked externally in user logic. In such cases, the width is viewed as 8 + 1, 16 + 2, or 32 + 4. These extra parity bits are stored and behave exactly as the other bits, including the timing parameters. Video applications can use the 9-bit ratio of BQR2V6000 block SelectRAM memory to advantage.

Each block SelectRAM cell is a fully synchronous memory, as illustrated in Figure 22. Input data bus and output data bus widths are identical.

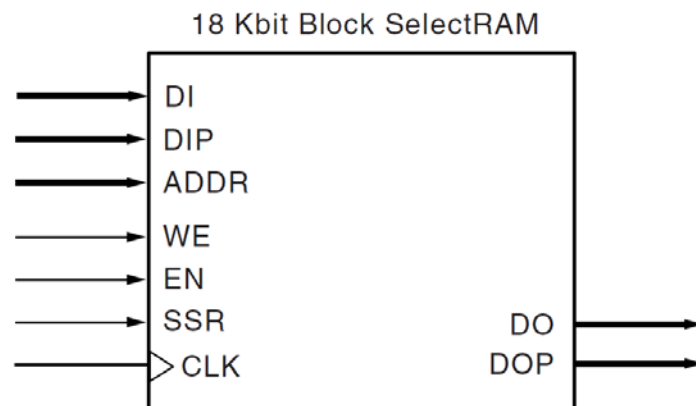

Figure 22 18 Kbit Block SelectRAM Memory in Single-Port Mode

Dual-Port Configuration

As a dual-port RAM, each port of block SelectRAM has access to a common 18 Kbit memory resource. These are fully synchronous ports with independent control signals for each port. The data widths of the two ports can be configured independently, providing built-in bus-width conversion. If both ports are configured in either 2K x 9-bit, 1K x 18-bit, or 512 x 36-bit configurations, the 18 Kbit block is accessible from Port A or B. If both ports are configured in either 16K x 1-bit, 8K x 2-bit, or 4K x 4-bit configurations, the 16 Kbit block is accessible from Port A or Port B. All other configurations result in one port having access to an 18 Kbit memory block and the other port having access to a 16 Kbit subset of the memory block equal

to 16 Kbits. Each block SelectRAM cell is a fully synchronous memory, as illustrated in Figure 23. The two ports have independent inputs and outputs and are independently clocked.

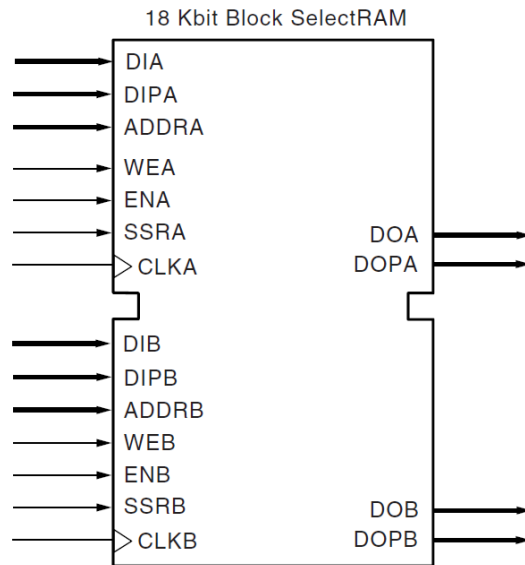

Figure 23 18 Kbit Block SelectRAM in Dual-Port Mode

Port Aspect Ratios

Table 14 shows the depth and the width aspect ratios for the 18 Kbit block SelectRAM. BQR2V6000 block SelectRAM also includes dedicated routing resources to provide an efficient interface with CLBs, block SelectRAM, and multipliers.

Table 13 18Kbit Block SelectRAM Port Aspect Ratio

Width	Depth	Address Bus	Data Bus	Parity Bus
1	16,384	ADDR[13:0]	DATA[0]	N/A
2	8,192	ADDR[12:0]	DATA[1:0]	N/A
4	4,096	ADDR[11:0]	DATA[3:0]	N/A
9	2,048	ADDR[10:0]	DATA[7:0]	Parity[0]
18	1,024	ADDR[9:0]	DATA[15:0]	Parity[1:0]
36	512	ADDR[8:0]	DATA[31:0]	Parity[3:0]

Read/Write Operations

The BQR2V6000 block SelectRAM read operation is fully synchronous. An address is presented, and the read operation is enabled by control signals WEA and WEB in addition to ENA or ENB. Then, depending on clock polarity, a rising or

falling clock edge causes the stored data to be loaded into output registers. The write operation is also fully synchronous. Data and address are presented, and the write operation is enabled by control signals WEA or WEB in addition to ENA or ENB. Then, again depending on the clock input mode, a rising or falling clock edge causes the data to be loaded into the memory cell addressed. A write operation performs a simultaneous read operation. Three different options are available, selected by configuration:

1. WRITE_FIRST

The WRITE_FIRST option is a transparent mode. The same clock edge that writes the data input (DI) into the memory also transfers DI into the output registers DO as shown in Figure 24.

2. READ_FIRST

The READ_FIRST option is a read-before-write mode. The same clock edge that writes data input (DI) into the memory also transfers the prior content of the memory cell addressed into the data output registers DO, as shown in Figure 25

3. NO_CHANGE

The NO_CHANGE option maintains the content of the output registers, regardless of the write operation. The clock edge during the write mode has no effect on the content of the data output register DO. When the port is configured as NO_CHANGE, only a read operation loads a new value in the output register DO, as shown in Figure 26.

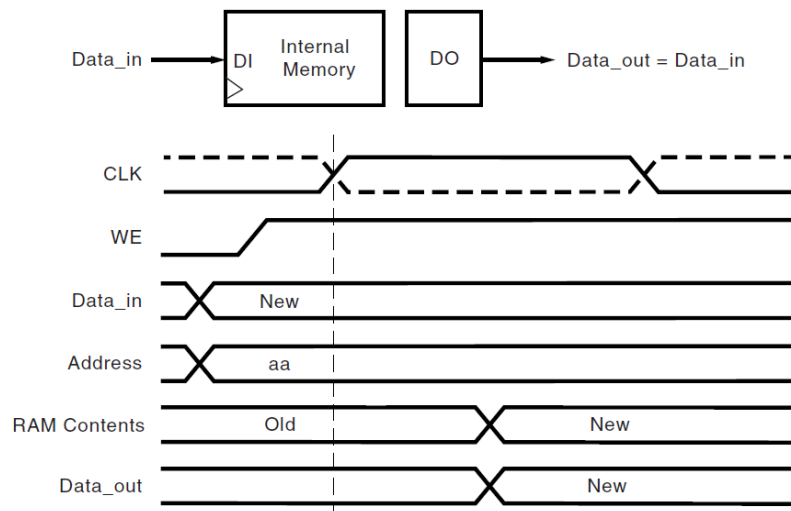

Figure 24 WRITE_FIRST Mode

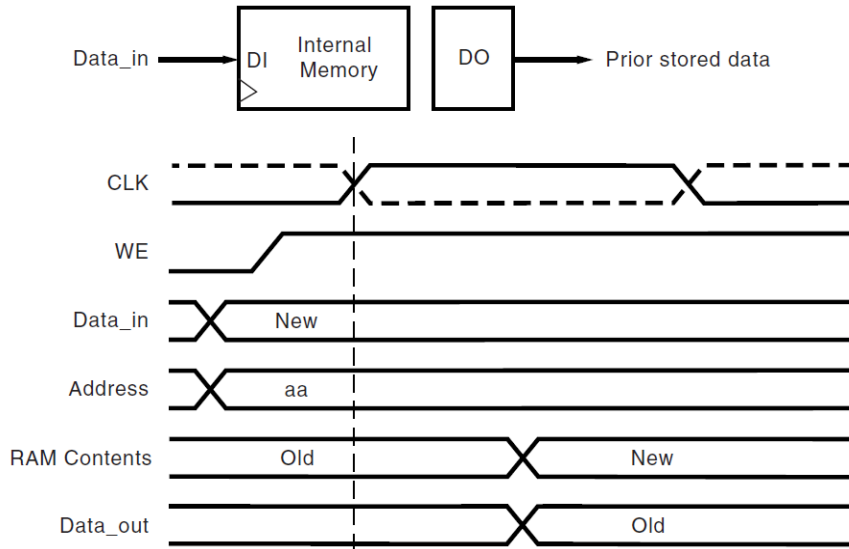

Figure 25 READ_FIRST Mode

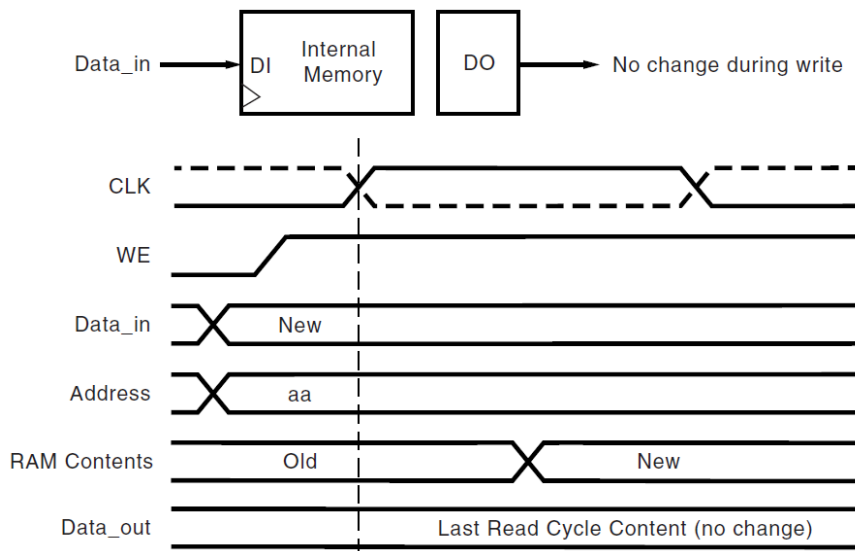

Figure 26 NO_CHANGE Mode

Control Pins and Attributes

BQR2V6000 SelectRAM memory has two independent ports with the control signals described in Table 15. All control inputs including the clock have an optional inversion.

Table 14 Control Functions

Control Signal	Function
CLK	Read and Write Clock
EN	Enable affects Read, Write, Set, Reset
WE	Write Enable

SSR	Set DO register to SRVAL (attribute)
-----	--------------------------------------

Initial memory content is determined by the INIT_xx attributes. Separate attributes determine the output register value after device configuration (INIT) and SSR is asserted(SRVAL). Both attributes (INIT_B and SRVAL) are available for each port when a block SelectRAM resource is configured as dual-port RAM.

BQR2V6000 SelectRAM memory blocks are located in six columns. Column locations are shown in Table 16.

Table 15 SelectRAM Memory Floor Plan

Device	Columns	SelectRAM Blocks	
		Per Column	Total
BQR2V6000	6	24	144

Table 17 shows the amount of block SelectRAM memory available for BQR2V6000. The 18 Kbit SelectRAM blocks are cascadable to implement deeper or wider single- or dual-port memory resources.

Table 16 BQR2V6000 SelectRAM Memory Available

Device	Total SelectRAM Memory		
	Blocks	in Kbits	in Bits
BQR2V6000	144	2,592	2,654,208

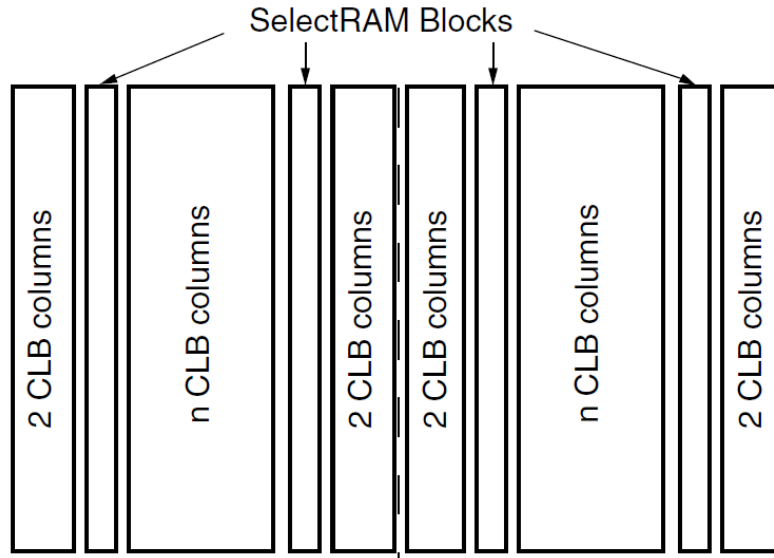

Figure 27 Block SelectRAM(4-column)

3.2.4 18-Bit×18-Bit Multipliers

A BQR2V6000 multiplier block is an 18-bit by 18-bit 2's complement signed multiplier. BQR2V6000 incorporate many embedded multiplier blocks. These multipliers can be associated with an 18 Kbit block SelectRAM resource or can be used independently. They are optimized for high-speed operations and have a lower power consumption compared to an 18-bit×18-bit multiplier in slices. Each SelectRAM memory and multiplier block is tied to four switch matrices, as shown in Figure 28.

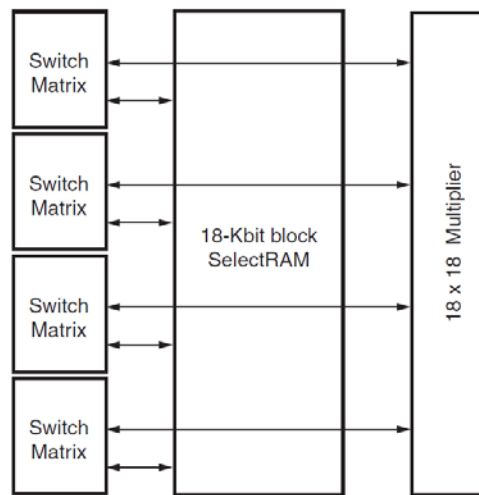

Figure 28 18-Bit×18-Bit Multipliers

The interconnect is designed to allow SelectRAM memory and multiplier blocks to be used at the same time, but some interconnect is shared between the SelectRAM and the multiplier. Thus, SelectRAM memory can be used only up to 18 bits wide when the multiplier is used, because the multiplier shares inputs with the upper data bits of the SelectRAM memory.

This sharing of the interconnect is optimized for an 18-bit-wide block SelectRAM resource feeding the multiplier. The use of SelectRAM memory and the multiplier with an accumulator in LUTs allows for implementation of a digital signal processor (DSP) multiplier-accumulator (MAC) function, which is commonly used in finite and infinite impulse response (FIR and IIR) digital filters.

The multiplier block is an 18-bit by 18-bit signed multiplier (2's complement). Both A and B are 18-bit-wide inputs, and the output is 36 bits. Figure 29 shows a multiplier block.

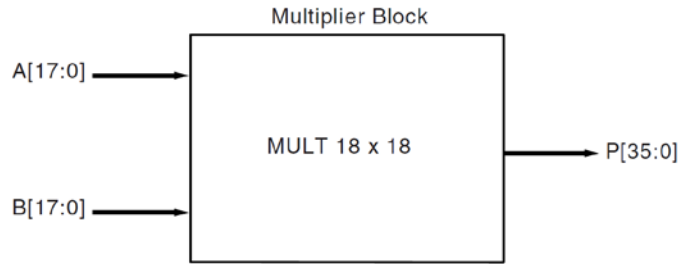

Figure 29 Multiplier Block

Multiplier organization is identical to the 18 Kbit SelectRAM organization, because each multiplier is associated with an 18 Kbit block SelectRAM resource.

In addition to the built-in multiplier blocks, the CLB elements have dedicated logic to implement efficient multipliers in logic.

Table 17 Multiplier Floor Plan

Device	Columns	Multipliers	
		Per Column	Total
BQR2V6000	6	24	144

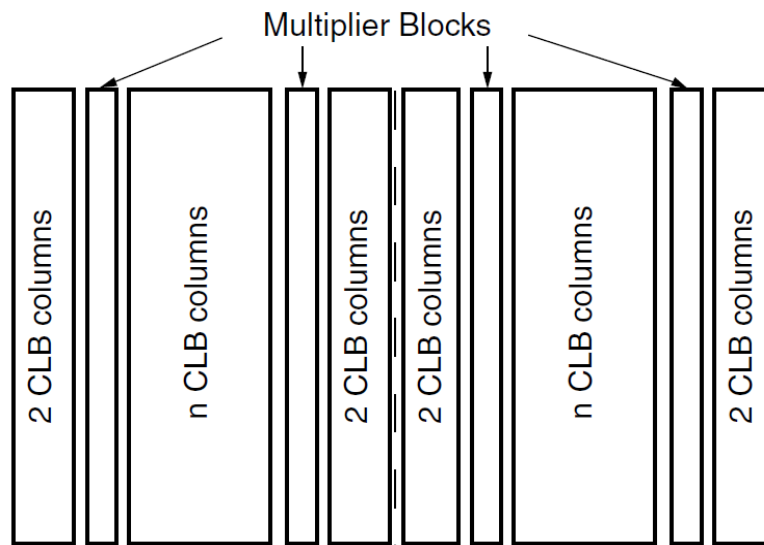

Figure 30 Multipliers(4-column)

3.2.5 Digital Clock Manager (DCM)

The BQR2V6000 DCM offers a wide range of powerful clock management features:

- **Clock De-skew:** The DCM generates new system clocks (either internally or externally to the FPGA), which are phase-aligned to the input clock, thus eliminating clock distribution delays.

- **Frequency Synthesis:** The DCM generates a wide range of output clock frequencies, performing very flexible clock multiplication and division.
- **Phase Shifting:** The DCM provides both coarse phase shifting and fine-grained phase shifting with dynamic phase shift control.

The DCM utilizes fully digital delay lines allowing robust high-precision control of clock phase and frequency. It also utilizes fully digital feedback systems, operating dynamically to compensate for temperature and voltage variations during operation.

Up to four of the nine DCM clock outputs can drive inputs to global clock buffers or global clock multiplexer buffers simultaneously (see Figure 31). All DCM clock outputs can simultaneously drive general routing resources, including routes to output buffers.

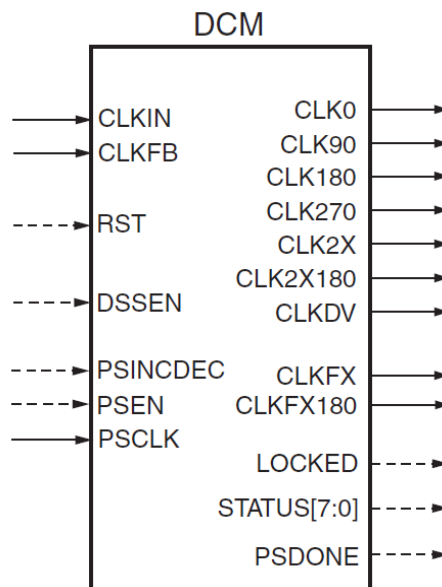

Figure 31 Digital Clock Manager

The DCM can be configured to delay the completion of the BQR2V6000 configuration process until after the DCM has achieved lock. This guarantees that the chip does not begin operating until after the system clocks generated by the DCM have stabilized.

The DCM has the following general control signals:

- RST input pin: resets the entire DCM.
- LOCKED output pin: asserted High when all enabled DCM circuits have locked.
- STATUS output pins (active High): shown in Table 19.

Table 18 DCM Statue Pins

Status Pin	Function
0	Phase Shift Overflow

1	CLKIN Stopped
2	CLKFX Stopped
3	N/A
4	N/A
5	N/A
6	N/A
7	N/A

Clock De-Skew

The DCM de-skews the output clocks relative to the input clock by automatically adjusting a digital delay line. Additional delay is introduced so that clock edges arrive at internal registers and block RAMs simultaneously with the clock edges arriving at the input clock pad. Alternatively, external clocks, which are also de-skewed relative to the input clock, can be generated for board-level routing. All DCM output clocks are phase-aligned to CLK0 and, therefore, are also phase-aligned to the input clock.

To achieve clock de-skew, the CLKFB input must be connected, and its source must be either CLK0 or CLK2X. CLKFB must always be connected, unless only the CLKFX or CLKFX180 outputs are used and de-skew is not required.

Frequency Synthesis

The DCM provides flexible methods for generating new clock frequencies. Each method has a different operating frequency range and different AC characteristics. The CLK2X and CLK2X180 outputs double the clock frequency. The CLKDV output creates divided output clocks with division options of 1.5, 2, 2.5, 3, 3.5, 4, 4.5, 5, 5.5, 6, 6.5, 7, 7.5, 8, 9, 10, 11, 12, 13, 14, 15, and 16. The CLKFX and CLKFX180 outputs can be used to produce clocks at the following frequency:

$$FREQ_{CLKFX} = (M/D) * FREQ_{CLKIN}$$

where M and D are two integers. By default, M=4 and D=1, which results in a clock output frequency four times faster than the clock input frequency (CLKIN).

CLK2X180 is phase shifted 180 degrees relative to CLK2X. CLKFX180 is phase shifted 180 degrees relative to CLKFX. All frequency synthesis outputs automatically have 50/50 duty cycles (with the exception of the CLKDV output when performing a non-integer divide in high-frequency mode).

Note: CLK2X and CLK2X180 are not available in high-frequency mode.

Phase Shifting

The DCM provides additional control over clock skew through either coarse- or fine-grained phase shifting. The CLK0, CLK90, CLK180, and CLK270 outputs are each phase shifted by 1/4 of the input clock period relative to each other, providing coarse phase control. Note that CLK90 and CLK270 are not available in high-frequency mode.

Fine-phase adjustment affects all nine DCM output clocks. When activated, the phase shift between the rising edges of CLKIN and CLKFB is a specified fraction of the input clock period.

In variable mode, the PHASE SHIFT value can also be dynamically incremented or decremented as determined by PSINCDEC synchronously to PSCLK, when the PSEN input is active. Figure 32 illustrates the effects of fine-phase shifting.

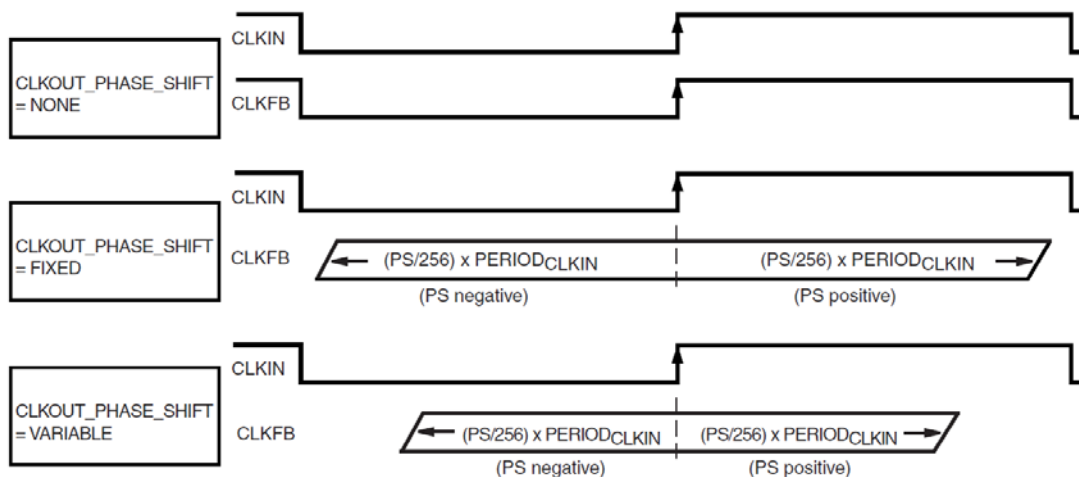

Figure 32 Fine-Phase Shifting Effects

Table 20 lists fine-phase shifting control pins, when used in variable mode.

Table 19 Fine-Phase Shifting Control Pins

Control Pin	Direction	Function
PSINCDEC	In	Increment or decrement
PSEN	In	Enable±phase shift
PSCLK	In	Clock for phase shift
PSDONE	Out	Active when completed

Two separate components of the phase shift range must be understood:

- PHASE_SHIFT attribute range
- FINE_SHIFT_RANGE DCM timing parameter range

The PHASE_SHIFT attribute is the numerator in the following equation:

$$\text{Phase Shift (ns)} = (\text{PHASE_SHIFT}/256) * \text{PERIODCLKIN}$$

The full range of this attribute is always -255 to +255, but its practical range varies with CLKIN frequency, as constrained by the FINE_SHIFT_RANGE component, which represents the total delay achievable by the phase shift delay line. Total delay is a function of the number of delay taps used in the circuit.

$$\text{Absolute range (fixed mode)} = \pm \text{FINE_SHIFT_RANGE}$$

$$\text{Absolute range (variable mode)} = \pm \text{FINE_SHIFT_RANGE}/2$$

The reason for the difference between fixed and variable modes is as follows. For variable mode to allow symmetric, dynamic sweeps from -255/256 to +255/256, the DCM sets the "zero phase skew" point as the middle of the delay line, thus dividing the total delay line range in half. In fixed mode, since the PHASE_SHIFT value never changes after configuration, the entire delay line is available for insertion into either the CLKIN or CLKFB path (to create either positive or negative skew).

Taking both of these components into consideration, the following are some usage examples:

- If $\text{PERIODCLKIN} = 2 * \text{FINE_SHIFT_RANGE}$, then PHASE_SHIFT in fixed mode is limited to ± 128 , and in variable mode it is limited to ± 64 .
- If $\text{PERIODCLKIN} = \text{FINE_SHIFT_RANGE}$, then PHASE_SHIFT in fixed mode is limited to ± 255 , and in variable mode it is limited to ± 128 .
- If $\text{PERIODCLKIN} \leq 0.5 * \text{FINE_SHIFT_RANGE}$, then PHASE_SHIFT is limited to ± 255 in either mode.

Operating Modes

The frequency ranges of DCM input and output clocks depend on the operating mode specified, either low-frequency mode or high-frequency mode, according to Table 21. The CLK2X, CLK2X180, CLK90, and CLK270 outputs are not available in high-frequency mode. High or low-frequency mode is selected by an attribute.

Table 20 DCM Frequency Ranges

Output Clock	Low-Frequency Mode		High-Frequency Mode	
	CLKIN Input	CLK Output	CLKIN Input	CLK Output
CLK0,CLK180	CLKIN_FREQ_DLL_LF	CLKOUT_FREQ_1X_LF	CLKIN_FREQ_DLL_HF	CLKOUT_FREQ_1X_HF
CLK90,CLK270	CLKIN_FREQ_DLL_LF	CLKOUT_FREQ_1X_LF	NA	NA
CLK2X,CLK2X180	CLKIN_FREQ_DLL_LF	CLKOUT_FREQ_2X_LF	NA	NA

Output Clock	Low-Frequency Mode		High-Frequency Mode	
	CLKIN Input	CLK Output	CLKIN Input	CLK Output
CLKDV	CLKIN_FREQ_DLL_LF	CLKOUT_FREQ_DV_LF	CLKIN_FREQ_DLL_HF	CLKOUT_FREQ_DV_HF
CLKFX,CLKFX180	CLKIN_FREQ_FX_LF	CLKOUT_FREQ_FX_LF	CLKIN_FREQ_FX_HF	CLKOUT_FREQ_FX_HF

BQR2V6000 DCMs are placed on the top and the bottom of each block RAM and multiplier column. The number of DCMs as shown in Table 22.

Table 21 DCM Organization

Device	Columns	DCMs
BQR2V6000	6	12

3.2.6 .Global Clock Multiplexer Buffers

The DCM and global clock multiplexer buffers provide a complete solution for designing high-speed clocking schemes.

BQR2V6000 have 16 clock input pins that can also be used as regular user I/Os. Eight clock pads are on the top edge of the device, in the middle of the array, and eight are on the bottom edge, as illustrated in Figure 33.

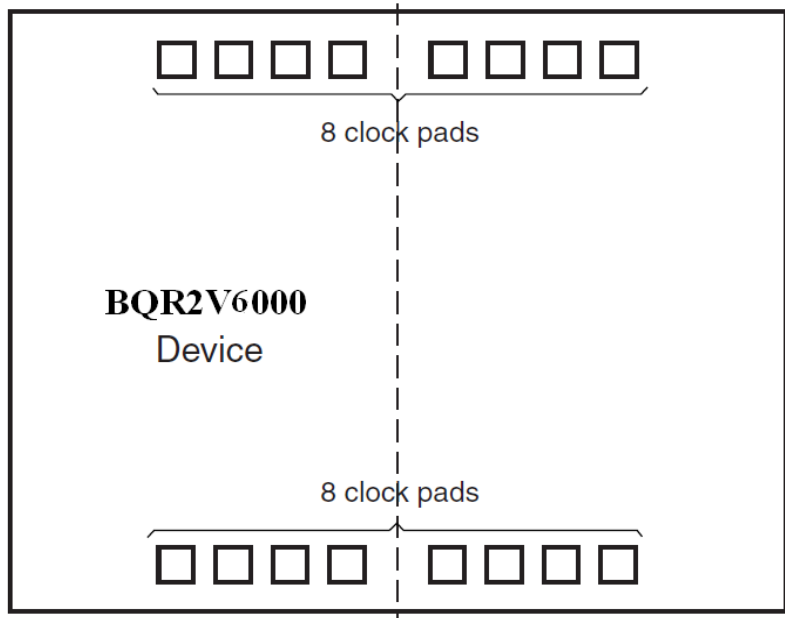

Figure 33 BQR2V6000 Clock Pads

Each global clock buffer can be driven by either the clock pad to distribute a clock directly to the device, or the Digital Clock Manager (DCM). Each global clock buffer can also be driven by local interconnects. The DCM has clock output(s) that can be connected to global clock buffer inputs, as shown in Figure 34.

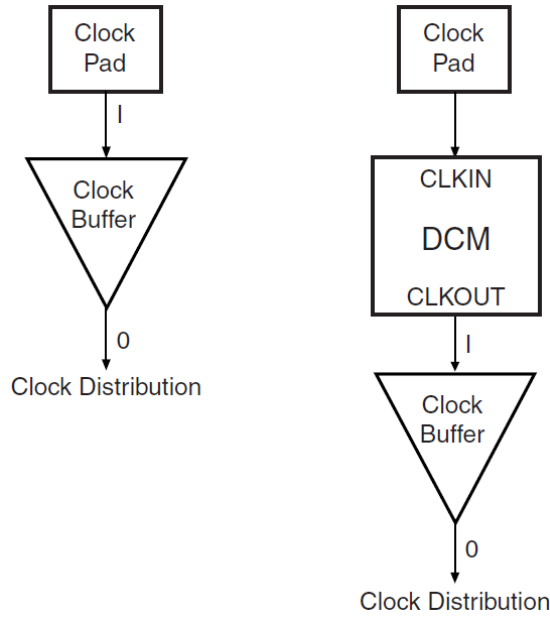

Figure 34 BQR2V6000 Clock Distribution Configurations

Global clock buffers are used to distribute the clock to some or all synchronous logic elements (such as registers in CLBs and IOBs, and SelectRAM blocks). Eight global clocks can be used in each quadrant of the BQR2V6000 device. Designers should consider the clock distribution detail of the device prior to pin-locking and floorplanning. Figure 35 shows clock distribution in BQR2V6000.

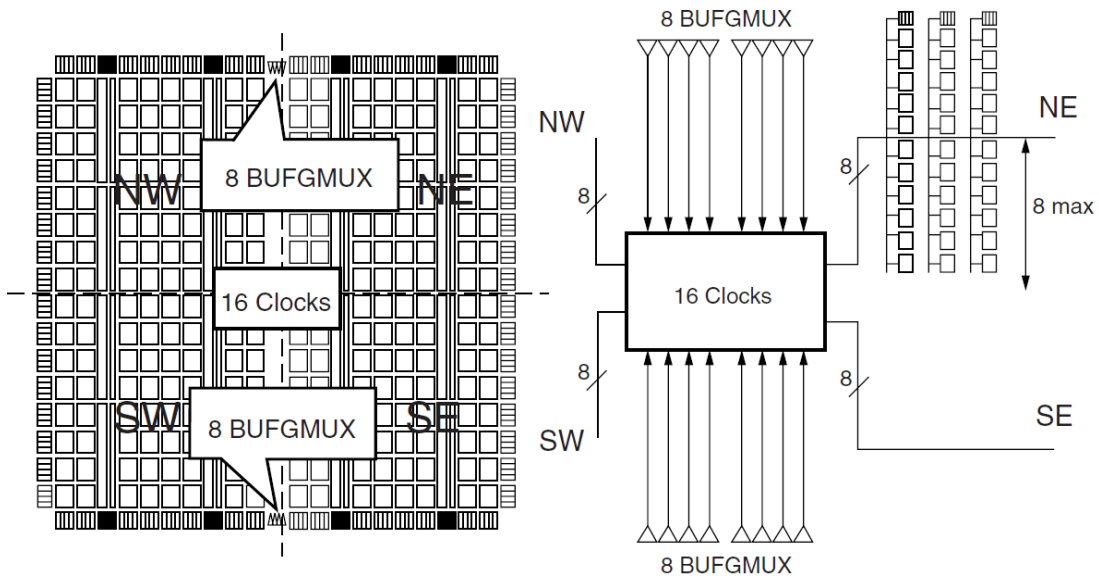

Figure 35 BQR2V6000 Clock Distribution

In each quadrant, up to eight clocks are organized in clock rows. A clock row supports up to 16 CLB rows (eight up and eight down). For the largest devices a new clock row is added, as necessary.

To reduce power consumption, any unused clock branches remain static.

Global clocks are driven by dedicated clock buffers (BUFG), which can also be used to gate the clock (BUFGCE) or to multiplex between two independent clock inputs (BUFGMUX).

The most common configuration option of this element is as a buffer. A BUFG function in this (global buffer) mode, is shown in Figure 36.

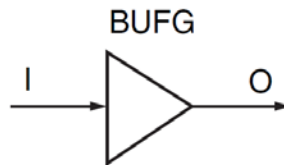

Figure 36 BQR2V6000 BUFG Function

The BQR2V6000 global clock buffer BUFG can also be configured as a clock enable/disable circuit (Figure 37), as well as a two-input clock multiplexer (Figure 38). A functional description of these two options is provided below. Each of them can be used in either of two modes, selected by configuration: rising clock edge or falling clock edge.

This section describes the rising clock edge option. For the opposite option, falling clock edge, just change all "rising" references to "falling" and all "High" references to "Low", except for the description of the CE or S levels. The rising clock edge option uses the BUFGCE and BUFGMUX primitives. The falling clock edge option uses the BUFGCE_1 and BUFGMUX_1 primitives.

BUFGCE

If the CE input is active (High) prior to the incoming rising clock edge, this Low-to-High-to-Low clock pulse passes through the clock buffer. Any level change of CE during the incoming clock High time has no effect.

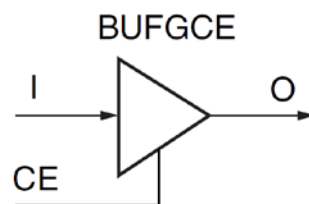

Figure 37 BQR2V6000 BUFGCE Function

If the CE input is inactive (Low) prior to the incoming rising clock edge, the following clock pulse does not pass through the clock buffer, and the output stays Low. Any level change of CE during the incoming clock High time has no effect. CE must not change during a short setup window just prior to the rising clock edge on the

BUFGCE input I. Violating this setup time requirement can result in an undefined runt pulse output.

BUFGMUX

BUFGMUX can switch between two unrelated, even asynchronous clocks. Basically, a Low on S selects the I0 input, and a High on S selects the I1 input. Switching from one clock to the other is done in such a way that the output High and Low time is never shorter than the shortest High or Low time of either input clock. As long as the presently selected clock is High, any level change of S has no effect.

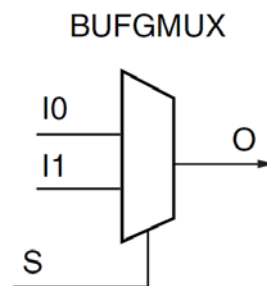

Figure 38 BQR2V6000 BUFGMUX Function

If the presently selected clock is Low while S changes, or if it goes Low after S has changed, the output is kept Low until the other ("to-be-selected") clock has made a transition from High to Low. At that instant, the new clock starts driving the output.

The two clock inputs can be asynchronous with regard to each other, and the S input can change at any time, except for a short setup time prior to the rising edge of the presently selected clock, that is, prior to the rising edge of the BUFGMUX output O. Violating this setup time requirement can result in an undefined runt pulse output.

BQR2V6000 have 16 global clock multiplexer buffers. Figure 39 shows a switchover from CLK0 to CLK1. In Figure 39:

- The current clock is CLK0.
- S is activated High.
- If CLK0 is currently High, the multiplexer waits for CLK0 to go Low.
- Once CLK0 is Low, the multiplexer output stays Low until CLK1 transitions High to Low.
- When CLK1 transitions from High to Low, the output switches to CLK1.

No glitches or short pulses can appear on the output.

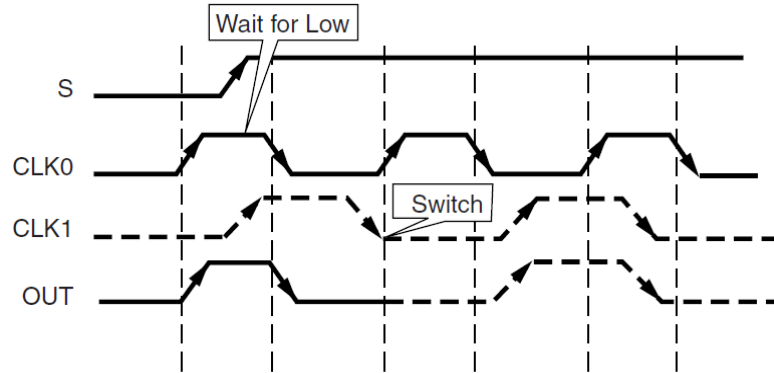

Figure 39 Clock Multiplexer Waveform Diagram

3.2.7 Routing Resources

Local and global BQR2V6000 routing resources are optimized for speed and timing predictability, as well as to facilitate cores implementation. BQR2V6000 Active Interconnect Technology is a fully buffered programmable routing matrix. All routing resources are segmented to offer the advantages of a hierarchical solution. BQR2V6000 logic features like CLBs, IOBs, block RAM, multipliers, and DCMs are all connected to an identical switch matrix for access to global routing resources, as shown in Figure 40.

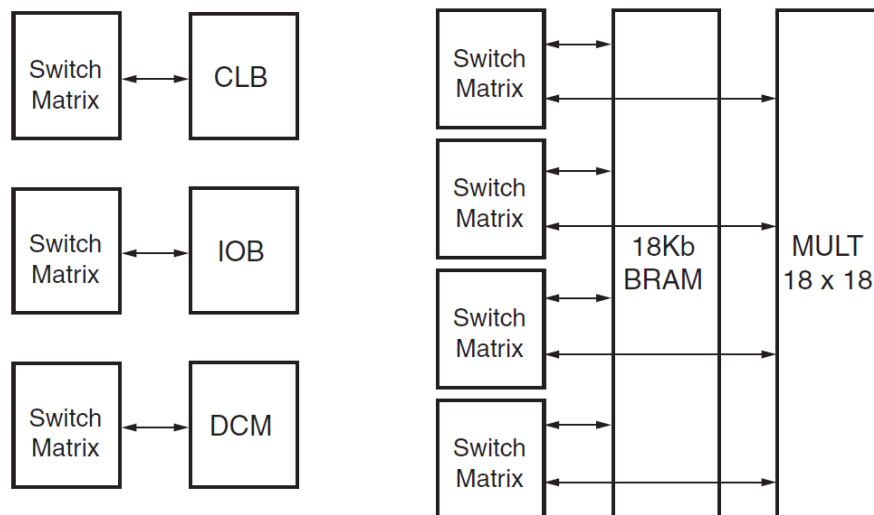

Figure 40 Active Interconnect Technology

Each BQR2V6000 device can be represented as an array of switch matrices with logic blocks attached, as illustrated in Figure 41.

Place-and-route software takes advantage of this regular array to deliver optimum system performance and fast compile times. The segmented routing resources are essential to guarantee IP cores portability and to efficiently handle an

incremental design flow that is based on modular implementations. Total design time is reduced due to fewer and shorter design iterations.

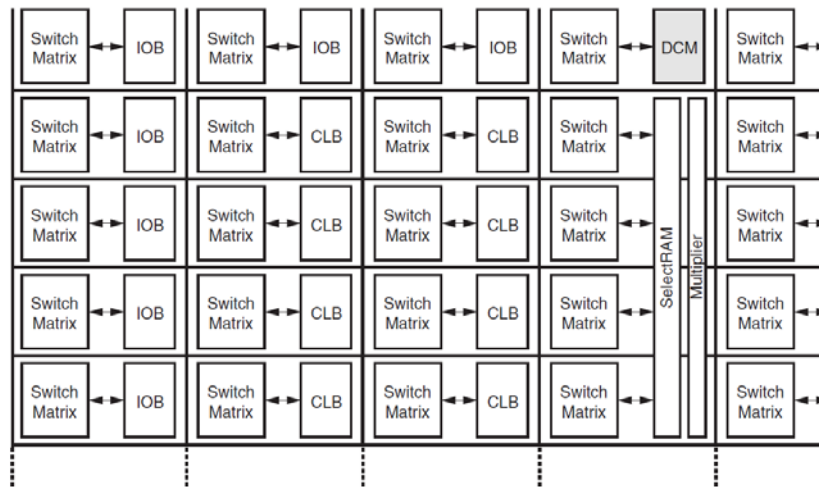

Figure 41 Routing Resource

Hierarchical Routing Resources

Most BQR2V6000 signals are routed using the global routing resources, which are located in horizontal and vertical routing channels between each switch matrix. As shown in Figure 42, BQR2V6000 device have fully buffered programmable interconnections, with a number of resources counted between any two adjacent switch matrix rows or columns. Fanout has minimal impact on the performance of each net. In Figure 42:

- Long lines are bidirectional wires that distribute signals across the device. Vertical and horizontal long lines span the full height and width of the device.
- Hex lines route signals to every third or sixth block away in all four directions. Organized in a staggered pattern, hex lines can only be driven from one end. Hex-line signals can be accessed either at the endpoints or at the midpoint (three blocks from the source).
- Double lines route signals to every first or second block away in all four directions. Organized in a staggered pattern, double lines can be driven only at their endpoints. Double-line signals can be accessed either at the endpoints or at the midpoint (one block from the source).
- Direct connect lines route signals to neighboring blocks: vertically, horizontally, and diagonally.
- Fast connect lines are the internal CLB local interconnections from LUT outputs to

LUT inputs.

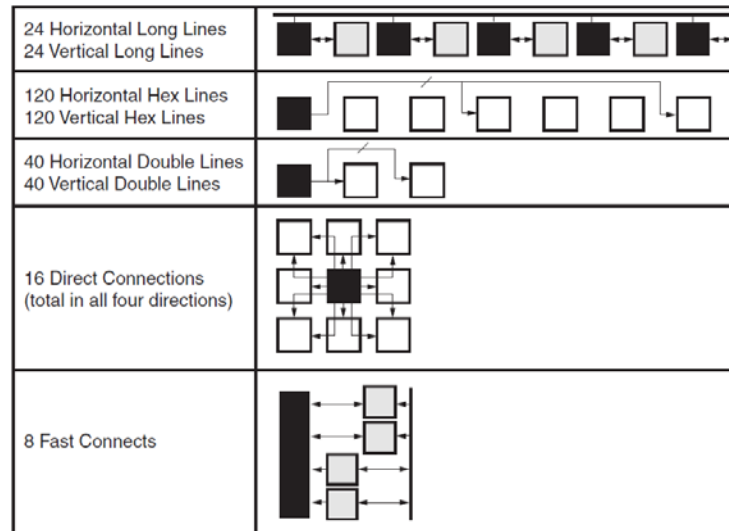

Figure 42 Hierarchical Routing Resources

Dedicated Routing

In addition to the global and local routing resources, dedicated signals are available:

- There are eight global clock nets per quadrant .
- Horizontal routing resources are provided for on-chip 3-state buses. Four partitionable bus lines are provided per CLB row, permitting multiple buses within a row.
- Two dedicated carry-chain resources per slice column (two per CLB column) propagate carry-chain MUXCY output signals vertically to the adjacent slice.
- One dedicated SOP chain per slice row (two per CLB row) propagates ORCY output logic signals horizontally to the adjacent slice.
- One dedicated shift chain per CLB connects the output of LUTs in shift-register mode to the input of the next LUT in shift-register mode (vertically) inside the CLB.

3.2.8 Boundary Scan

Boundary-scan instructions and associated data registers support a standard methodology for accessing and configuring BQR2V6000 device that complies with IEEE standards 1149.1-1993 and 1532. A system mode and a test mode are implemented. In system mode, a BQR2V6000 device performs its intended mission even while executing non-test boundary-scan instructions. In test mode,

boundary-scan test instructions control the I/O pins for testing purposes. The BQR2V6000 Test Access Port (TAP) supports BYPASS, PRELOAD, SAMPLE, IDCODE, and USERCODE non-test instructions. The EXTEST, INTEST, and HIGHZ test instructions are also supported.

3.3 Combinations and Maximum Number of Available I/Os

Table 22 Combinations and Maximum Number of Available I/Os

Package	Available I/Os
CCGA1144	824

4. Configuration

The BQR2V6000 device are configured by loading application-specific configuration data into the internal configuration memory. Configuration is carried out using a subset of the device pins, some of which are dedicated, while others can be re-used as general purpose inputs and outputs once configuration is complete.

Depending on the system design, several configuration modes are supported, selectable via mode pins. The mode pins M2, M1, and M0 are dedicated pins. An additional pin, HSWAP_EN, is used in conjunction with the mode pins to select whether user I/O pins have pull-ups during configuration. By default, HSWAP_EN is tied High (internal pull-up), which shuts off the pull-ups on the user I/O pins during configuration. When HSWAP_EN is tied Low, user I/Os have pull-ups during configuration. Other dedicated pins are CCLK (the configuration clock pin), DONE, PROG_B, and the boundary-scan pins: TDI, TDO, TMS, and TCK. Depending on the configuration mode chosen, CCLK can be an output generated by the FPGA, or an input accepting an externally generated clock. The configuration pins and boundary-scan pins are independent of the VCCO. The auxiliary power supply (VCCAUX) of 3.3V is used for these pins. All configuration pins are LVTTTL 12 mA.

A persist option is available which can be used to force the configuration pins to retain their configuration function even after device configuration is complete. If the persist option is not selected, then the configuration pins with the exception of CCLK, PROG_B, and DONE can be used as user I/O in normal operation. The persist option does not apply to the boundary-scan related pins. The persist feature is valuable in applications which employ partial reconfiguration or reconfiguration on the fly.

4.1 Configuration Modes

BQR2V6000 supports the following five configuration modes:

- Slave-serial mode
- Master-serial mode
- Slave SelectMAP mode
- Master SelectMAP mode
- Boundary-Scan mode (IEEE 1532/IEEE 1149)

4.2 Slave-Serial Mode

In slave-serial mode, the FPGA receives configuration data in bit-serial form from a serial PROM or other serial source of configuration data. The CCLK pin on the FPGA is an input in this mode. The serial bitstream must be setup at the DIN input pin a short time before each rising edge of the externally generated CCLK.

Multiple FPGAs can be daisy chained for configuration from a single source. After a particular FPGA has been configured, the data for the next device is routed internally to the DOUT pin. The data on the DOUT pin changes on the rising edge of CCLK.

Slave-serial mode is selected by applying <111> to the mode pins (M2, M1, M0). A weak pull-up on the mode pins makes slave serial the default mode if the pins are left unconnected.

4.3 Master-Serial Mode

In master-serial mode, the CCLK pin is an output pin. It is the BQR2V6000 device that drives the configuration clock on the CCLK pin to a BMTI or Xilinx Serial PROM, which in turn feeds bit-serial data to the DIN input. The FPGA accepts this data on each rising CCLK edge. After the FPGA has been loaded, the data for the next device in a daisy chain is presented on the DOUT pin after the rising CCLK edge.

The interface is identical to slave serial except that an internal oscillator is used to generate the configuration clock (CCLK). A wide range of frequencies can be selected for CCLK, which always starts at a slow default frequency. Configuration bits then switch CCLK to a higher frequency for the remainder of the configuration.

4.4 Slave SelectMAP Mode

The SelectMAP mode is the fastest configuration option. Byte-wide data is written into the BQR2V6000 device with a BUSY flag controlling the flow of data. An external data source provides a byte stream, CCLK, an active-Low Chip Select (CS_B) signal, and a Write signal (RDWR_B). If BUSY is asserted (High) by the FPGA, the data must be held until BUSY goes Low. Data can also be read using the SelectMAP mode. If RDWR_B is asserted, configuration data is read out of the FPGA as part of a readback operation.

After configuration, the pins of the SelectMAP port can be used as additional user I/O. Alternatively, the port can be retained to permit high-speed 8-bit readback using the persist option.

Multiple BQR2V6000 can be configured using the SelectMAP mode, and can be made to start-up simultaneously. To configure multiple device in this way, wire the individual CCLK, Data, RDWR_B, and BUSY pins of all the device in parallel. The individual device are loaded separately by deasserting the CS_B pin of each device in turn and writing the appropriate data.

4.5 Master SelectMAP Mode

This mode is a master version of the SelectMAP mode. The device is configured byte-wide on a CCLK supplied by the BQR2V6000. Timing is similar to the Slave SerialMAP mode except that CCLK is supplied by the BQR2V6000.

4.6 Boundary-Scan (JTAG, IEEE 1532) Mode

In boundary-scan mode, dedicated pins are used for configuring the BQR2V6000 device. The configuration is done entirely through the IEEE 1149.1 Test Access Port (TAP). BQR2V6000 device configuration using boundary scan is compliant with IEEE 1149.1-1993 standard and the new

IEEE 1532 standard for In-System Configurable (ISC) device. The IEEE 1532 standard is backward compliant with the IEEE 1149.1-1993 TAP and state machine. The IEEE Standard 1532 for In-System Configurable (ISC) device is intended to be programmed, reprogrammed, or tested on the board via a physical and logical protocol.

Configuration through the boundary-scan port is always available, independent of the mode selection. Selecting the boundary-scan mode simply turns off the other modes.

Table 23 BQR2V6000 Configuration Mode Pin Settings

Configuration Mode ⁽¹⁾	M2	M1	M0	CCLK Direction	Data Width	Serial Dout ⁽²⁾
Master Serial	0	0	0	Out	1	Yes
Slave Serial	1	1	1	In	1	Yes
Master SelectMAP	0	1	1	Out	8	No
Slave SelectMAP	1	1	0	In	8	No
Boundary Scan	1	0	1	N/A	1	No

Notes:

1. The HSWAP_EN pin controls the pullups. Setting M2, M1, and M0 selects the configuration mode, while the HSWAP_EN pin controls whether or not the pullups are used.
2. Daisy chaining is possible only in modes where Serial DOUT is used. For example, in SelectMAP modes, the first device does NOT support daisy chaining of downstream device.

4.7 Configuration Sequence

The configuration of BQR2V6000 device is a three-phase process after Power On Reset or POR. POR occurs when VCCINT is greater than 1.2V, VCCAUX is greater than 2.5V, and VCCO (bank 4) is greater than 1.5V. Once the POR voltages have been reached, the three-phase process begins.

First, the configuration memory is cleared. Next, configuration data is loaded into the memory, and finally, the logic is activated by a start-up process.

Configuration is automatically initiated on power-up unless it is delayed by the user. The INIT_B pin can be held Low using an open-drain driver. An open-drain is required since INIT_B is a bidirectional open-drain pin that is held Low by a BQR2V6000 device while the configuration memory is being cleared. Extending the time that the pin is Low causes the configuration sequencer to wait. Thus, configuration is delayed by preventing entry into the phase where data is loaded.

The configuration process can also be initiated by asserting the PROG_B pin. The end of the memory-clearing phase is signaled by the INIT_B pin going High, and the

completion of the entire process is signaled by the DONE pin going High. The Global Set/Reset (GSR) signal is pulsed after the last frame of configuration data is written but before the start-up sequence. The GSR signal resets all flip-flops on the device.

The default start-up sequence is that one CCLK cycle after DONE goes High, the global 3-state signal (GTS) is released. This permits device outputs to turn on as necessary. One CCLK cycle later, the Global Write Enable (GWE) signal is released. This permits the internal storage elements to begin changing state in response to the logic and the user clock.

The relative timing of these events can be changed via configuration options in software. In addition, the GTS and GWE events can be made dependent on the DONE pins of multiple device all going High, forcing the device to start synchronously. The sequence can also be paused at any stage, until lock has been achieved on any or all DCMs, as well as the DCI.

4.8 Readback

In this mode, configuration data from the BQR2V6000 device can be read back. Readback is supported only in the SelectMAP (master and slave) and Boundary Scan modes.

Along with the configuration data, it is possible to read back the contents of all registers, distributed SelectRAM, and block RAM resources. This capability is used for real-time debugging.

4.9 Bitstream Encryption

BQR2V6000 device have an on-chip decryptor using one or two sets of three keys for triple-key Data Encryption Standard (DES) operation. Xilinx software tools offer an optional encryption of the configuration data (bitstream) with a triple-key DES determined by the designer.

The keys are stored in the FPGA by JTAG instruction and retained by a battery connected to the VBATT pin, when the device is not powered. BQR2V6000 device can be configured with the corresponding encrypted bitstream, using any of the configuration modes described previously.

4.10 Partial Reconfiguration

Partial reconfiguration of BQR2V6000 device can be accomplished in either Slave SelectMAP mode or Boundary-Scan mode. Instead of resetting the chip and doing a full configuration, new data is loaded into a specified area of the chip, while the rest of the chip remains in operation. Data is loaded on a column basis, with the smallest load unit being a configuration “frame” of the bitstream (device size dependent).

Partial reconfiguration is useful for applications that require different designs to be loaded into the same area of a chip, or that require the ability to change portions of a design without having to reset or reconfigure the entire chip.

5. Electrical Characteristics

BQR2V6000 DC and AC characteristics are specified for military and space grade. All supply voltage and junction temperature specifications are representative of worst-case conditions. The parameters included are common to popular designs and typical applications.

5.1 DC Characteristics

Table 24 Absolute Maximum Ratings

Symbol	Description ⁽¹⁾		Units
V _{CCINT}	Internal supply voltage relative to GND	-0.5 to 1.65	V
V _{CCAUX}	Auxiliary supply voltage relative to GND	-0.5 to 4.0	V
V _{CCO}	Output drivers supply voltage relative to GND	-0.5 to 4.0	V
V _{BATT}	Key memory battery backup supply	-0.5 to 4.0	V
V _{REF}	Input reference voltage	-0.5 to V _{CCO} + 0.5	V
V _{IN} ⁽²⁾	Input voltage relative to GND (user and dedicated I/Os)	-0.5 to V _{CCO} + 0.5	V
V _{TS}	Voltage applied to 3-state output (user and dedicated I/Os)	-0.5 to 4.0	V
T _{STG}	Storage temperature (ambient)	-65 to +150	°C
T _{SOL}	Maximum soldering temperature	+220	°C
T _J	Operating junction temperature	+145	°C

Notes:

1. Stresses beyond those listed under Absolute Maximum Ratings might cause permanent damage to the device. These are stress ratings only, and functional operation of the device at these or any other conditions beyond those listed under Operating Conditions is not implied. Exposure to Absolute Maximum Ratings conditions for extended periods of time might affect device reliability.
2. Inputs configured as PCI are fully PCI compliant. This statement takes precedence over any specification that would imply that the device is not PCI compliant.

Table 25 Recommended Operating Conditions

Symbol	Description	Min	Max	Units
V_{CCINT}	Internal supply voltage relative to GND, $T_C = -55^\circ\text{C}$ to $+125^\circ\text{C}$	1.425	1.575	V
V_{CCAUX}	Auxiliary supply voltage relative to GND, $T_C = -55^\circ\text{C}$ to $+125^\circ\text{C}$	3.135	3.465	V
V_{CCO}	Supply voltage relative to GND, $T_C = -55^\circ\text{C}$ to $+125^\circ\text{C}$	1.2	3.6	V
V_{BATT}	Battery voltage relative to GND, $T_C = -55^\circ\text{C}$ to $+125^\circ\text{C}$	1.0	3.6	V

Notes:

1. If battery is not used, connect V_{BATT} to GND or V_{CCAUX} .
2. Recommended maximum voltage droop for V_{CCAUX} is 10 mV/ms.
3. The thresholds for Power On Reset are $V_{CCINT} > 1.2\text{V}$, $V_{CCAUX} > 2.5\text{V}$, and V_{CCO} (Bank 4) $> 1.5\text{V}$.
4. Limit the noise at the power supply to be within 200 mV peak-to-peak.

Table 26 DC Characteristics Over Recommended Operating Conditions

Symbol	Description	Device	Min	Max	Units
V_{DRINT}	Data Retention V_{CCINT} Voltage	All	1.2		V
V_{DRI}	Data Retention V_{CCAUX} Voltage	All	2.5		V
I_{REF}	V_{REF} current per bank	All	-10	+10	μA
I_L	Input leakage current	All	-10	+10	μA
C_{IN}	Input capacitance	All		20	pF
I_{RPU}	Pad pull-up (when selected) @ $V_{in} = 0\text{V}$, $V_{CCO} = 3.3\text{V}$ (sample tested)	All	Note 1	250	μA
I_{RPD}	Pad pull-down (when selected) @ $V_{in} = 3.6\text{V}$ (sample tested)	All	Note 1	250	μA
I_{BATT}	Battery supply current	All		100	nA

Notes:

1. Internal pull-up and pull-down resistors guarantee valid logic levels at unconnected input pins. These pull-up and pull-down resistors do not guarantee valid logic levels when input pins are connected to other circuits.

Table 27 Quiescent Supply Current

Symbol	Description	Min	Typical	Max	Units
I_{CCINTQ}	Quiescent V_{CCINT} supply current ⁽³⁾	–	100	0.50	A
I_{CCOQ}	Quiescent V_{CCO} supply current ^(1,2)	–	1.0	6.25	mA
I_{CCAUXQ}	Quiescent V_{CCAUX} supply current ^(1,2)	–	10	95	mA

Notes:

1. With no output current loads and no active input pull-up resistors. All I/O pins are 3-stated and floating.
2. If DCI or differential signaling is used, more accurate values can be obtained by using the Power Estimator or XPOWER.
3. Quiescent V_{CCINT} supply current may attain hundreds milliamperes at high temperature, which should be considered when supply system is designing.

5.2 Power-On Power Supply Requirements

BQR2V6000 requires a certain amount of supply current during power-on to ensure proper device operation. The actual current consumed depends on the power-on ramp rate of the power supply.

The V_{CCINT} , V_{CCAUX} , and V_{CCO} power supplies shall each ramp on no faster than 200 μ s and no slower than 50 ms. Ramp on is defined as: 0 V_{DC} to minimum supply voltages.

Table 29 shows the minimum current required by BQR2V6000 device for proper power on and configuration.

Power supplies can be turned on in any sequence. If any V_{CCO} bank powers up before V_{CCAUX} , then each bank draws up to 300 mA, worst case, until the V_{CCAUX} powers on. This does not harm the device. If the current is limited to the minimum value above, or larger, the device powers on properly after all three supplies have passed through their power on reset threshold voltages.

Note: The 300 mA is transient current (peak). It eventually disappears even if V_{CCAUX}

does not power up.

Once initialized and configured, use the power calculator to estimate current drain on these supplies.

Table 28 Maximum Power On Current Required for BQR2V6000 Device

Current	Device (mA)
	BQR2V6000
$I_{CCINTMAX}$	1300
$I_{CCAUXMAX}$	95
I_{CCOMAX}	6.25

Notes:

1. Values specified for power on current parameters are Military Grade.
2. I_{CCOMAX} values listed here apply to the entire device (all banks).

5.3 General Power Supply Requirements

Proper decoupling of all FPGA power supplies is essential. Consult Power Distribution System (PDS) Design: Using Bypass/Decoupling Capacitors, for detailed information on power distribution system design.

Quiescent V_{CCINT} supply current may attain hundreds milliamperes at high temperature, which should be considered when supply system is designing.

V_{CCAUX} powers critical resources in the FPGA. Thus, V_{CCAUX} is especially susceptible to power supply noise.

Changes in V_{CCAUX} voltage outside of 200 mV peak to peak should take place at a rate no faster than 10 mV per millisecond.

V_{CCAUX} can share a power plane with 3.3V V_{CCO} , but only if V_{CCO} does not have excessive noise. Using simultaneously switching output (SSO) limits are essential for keeping power supply noise to a minimum.

5.4 DC Input and Output Levels

Values for V_{IL} and V_{IH} are recommended input voltages. Values for I_{OL} and I_{OH} are guaranteed over the recommended operating conditions at the V_{OL} and V_{OH} test points. Only selected standards are tested. These are chosen to ensure that all standards meet their specifications. The selected standards are tested at minimum V_{CCO} with the respective V_{OL} and V_{OH} voltage levels shown. Other standards are

sample tested.

5.5 LDT Differential Signal DC Specifications (LDT_25)

Table 29 LDT DC Specifications

DC Parameter	Symbol	Conditions	Min	Typ	Max	Units
Differential Output Voltage	V_{OD}	$R_T = 100\Omega$ across Q and $\sim Q$ signals	500	600	700	mV
Change in V_{OD} Magnitude	ΔV_{OD}		-15		15	mV
Output Common Mode Voltage	V_{OCM}	$R_T = 100\Omega$ across Q and $\sim Q$ signals	560	600	640	mV
Change in V_{OS} Magnitude	ΔV_{OCM}		-15		15	mV
Input Differential Voltage	V_{ID}		200	600	1000	mV
Change in V_{ID} Magnitude	ΔV_{ID}		-15		15	mV
Input Common Mode Voltage	V_{ICM}		500	600	700	mV
Change in V_{ICM} Magnitude	ΔV_{ICM}		-15		15	mV

5.6 LVDS DC Specifications (LVDS_33 and LVDS_25)

Table 30 LVDS DC Specifications

DC Parameter	Symbol	Conditions	Min	Typ	Max	Units
Supply Voltage	V_{CCO}			3.3 or 2.5		V
Output High Voltage for Q and \bar{Q}	V_{OH}	$R_T = 100\Omega$ across Q and $\sim Q$ signals			1.575	V
Output Low Voltage for Q and \bar{Q}	V_{OL}	$R_T = 100\Omega$ across Q and $\sim Q$ signals	0.925			V
Differential Output Voltage (Q – \bar{Q}), Q = High (Q – \bar{Q}), Q = High	V_{ODIFF}	$R_T = 100\Omega$ across Q and $\sim Q$ signals	250	350	400	mV
Output Common-Mode Voltage	V_{OCM}	$R_T = 100\Omega$ across Q and $\sim Q$ signals	1.125	1.2	1.375	V
Differential Input Voltage (Q – \bar{Q}),	V_{IDIFF}	Common-mode input voltage = 1.25 V	100	350	N/A	mV

DC Parameter	Symbol	Conditions	Min	Typ	Max	Units
Q = High (Q – Q), Q = High						
Input Common-Mode Voltage	V_{ICM}	Differential input voltage = ± 350 mV	0.2	1.25	$V_{CCO} - 0.5$	V

5.7 Extended LVDS DC Specifications (LVDSEXT_33 and LVDSEXT_25)

Table 31 Extended LVDS DC Specifications

DC Parameter	Symbol	Conditions	Min	Typ	Max	Units
Supply Voltage	V_{CCO}			3.3 or 2.5		V
Output High Voltage for Q and Q	V_{OH}	$R_T = 100 \Omega$ across Q and $\sim Q$ signals			1.785	V
Output Low Voltage for Q and Q	V_{OL}	$R_T = 100 \Omega$ across Q and $\sim Q$ signals	0.705			V
Differential Output Voltage (Q – Q), Q = High (Q – Q), Q = High	V_{ODIFF}	$R_T = 100 \Omega$ across Q and $\sim Q$ signals	440		820	mV
Output Common-Mode Voltage	V_{OCM}	$R_T = 100 \Omega$ across Q and $\sim Q$ signals	1.125	1.2	1.375	V
Differential Input Voltage (Q – Q), Q = High (Q – Q), Q = High	V_{IDIFF}	Common-mode input voltage = 1.25 V	100	350	N/A	mV
Input Common-Mode Voltage	V_{ICM}	Differential input voltage = ± 350 mV	0.2	1.25	$V_{CCO} - 0.5$	V

5.8 LVPECL DC Specifications

These values are valid when driving a 100 Ω differential load only, i.e., a 100 Ω resistor between the two receiver pins. The V_{OH} levels are 200mV below standard LVPECL levels and are compatible with device tolerant of lower common-mode ranges. Table 33 summarizes the DC output specifications of LVPECL.

Table 32 LVPECL DC Specifications

DC Parameter	Min	Max	Min	Max	Min	Max	Units
V _{CCO}	3.0		3.3		3.6		V
V _{OH}	1.8	2.11	1.92	2.28	2.13	2.41	V
V _{OL}	0.96	1.27	1.06	1.43	1.30	1.57	V
V _{IH}	1.49	2.72	1.49	2.72	1.49	2.72	V
V _{IL}	0.86	2.125	0.86	2.125	0.86	2.125	V
Differential Input Voltage	0.3	–	0.3	–	0.3	–	V

6. Pin Definitions

Table 34 provides a description of each pin type listed in BQR2V6000 pinout tables.

Table 33 BQR2V6000 Pin Definitions

Pin Name	Direction	Description
User I/O Pins		
IO_LXXY_#	Input/Output	<p>All user I/O pins are capable of differential signalling and can implement LVDS, ULVDS, BLVDS, LVPECL, or LDT pairs. Each user I/O is labeled IO_LXXY_#”, where:</p> <ul style="list-style-type: none"> • IO indicates a user I/O pin. • LXXY indicates a differential pair, with XX a unique pair in the bank and Y = P/N for the positive and negative sides of the differential pair. • # indicates the bank number (0 through 7).
Dual-Function Pins		
IO_LXXY_#/ZZZ		<ul style="list-style-type: none"> • The dual-function pins are labelled “IO_LXXY_#/ZZZ”, where ZZZ can be one of the following pins: • Per Bank - VRP, VRN, or VREF • Globally - GCLKX(S/P), BUSY/DOUT, INIT_B, DIN/D0 – D7, RDWR_B, or CS_B
With /ZZZ		
DIN/D0, D1, D2, D3, D4, D5, D6, D7	Input/Output	<ul style="list-style-type: none"> • In SelectMAP mode, D0 through D7 are configuration data pins. These pins become user I/Os after configuration, unless the SelectMAP port is retained.

Pin Name	Direction	Description
		<ul style="list-style-type: none"> In bit-serial modes, DIN (D0) is the single-data input. This pin becomes a user I/O after configuration.
CS_B	Input	In SelectMAP mode, this is the active-Low Chip Select signal. This pin becomes a user I/O after configuration, unless the SelectMAP port is retained.
RDWR_B	Input	In SelectMAP mode, this is the active-Low Write Enable signal. This pin becomes a user I/O after configuration, unless the SelectMAP port is retained.
BUSY/DOUT	Output	<ul style="list-style-type: none"> In SelectMAP mode, BUSY controls the rate at which configuration data is loaded. This pin becomes a user I/O after configuration, unless the SelectMAP port is retained. In bit-serial modes, DOUT provides preamble and configuration data to downstream device in a daisy chain. This pin becomes a user I/O after configuration.
INIT_B	Bidirectional (open-drain)	When Low, this pin indicates that the configuration memory is being cleared. When held Low, the start of configuration is delayed. During configuration, a Low on this output indicates that a configuration data error has occurred. This pin becomes a user I/O after configuration.
GCLK _x (S/P)	Input/Output	These are clock input pins that connect to Global Clock Buffers. These pins become regular user I/Os when not needed for clocks.
VRP	Input	This pin is for the DCI voltage reference resistor of the P transistor (per bank).
VRN	Input	This pin is for the DCI voltage reference resistor of the N transistor (per bank).
ALT_VRP	Input	This is the alternative pin for the DCI voltage reference resistor of the P transistor.
ALT_VRN	Input	This is the alternative pin for the DCI voltage reference resistor of the N transistor.
V _{REF}	Input	These are input threshold voltage pins. They become user I/Os when an external threshold voltage is not needed (per bank).
Dedicated Pins ⁽¹⁾		
CCLK	Input/Output	Configuration clock. Output in Master mode or Input in Slave mode.
PROG_B	Input	Active Low asynchronous reset to configuration logic. This pin has a

Pin Name	Direction	Description
		permanent weak pull-up resistor.
DONE	Input/Output	DONE is a bidirectional signal with an optional internal pull-up resistor. As an output, this pin indicates completion of the configuration process. As an input, a Low level on DONE can be configured to delay the start-up sequence.
M2, M1, M0	Input	Configuration mode selection.
HSWAP_EN	Input	Enable I/O pullups during configuration.
TCK	Input	Boundary Scan Clock.
TDI	Input	Boundary Scan Data Input.
TDO	Output	Boundary Scan Data Output.
TMS	Input	Boundary Scan Mode Select.
PWRDWN_B	Input (<i>unsupported</i>)	Active Low power-down pin (<i>unsupported</i>). <i>Driving this pin Low can adversely affect device operation and configuration.</i> PWRDWN_B is internally pulled High, which is its default state. It does not require an external pull-up.
Other Pins		
DXN, DXP	N/A	Temperature-sensing diode pins (Anode: DXP, Cathode: DXN).
V _{BATT}	Input	Decryptor key memory backup supply. (Do not connect if battery is not used.)
RSVD	N/A	Reserved pin - do not connect.
V _{CC0}	Input	Power-supply pins for the output drivers (per bank).
V _{CCAUX}	Input	Power-supply pins for auxiliary circuits.
V _{CCINT}	Input	Power-supply pins for the internal core logic.
GND	Input	Ground.

Notes:

1. All dedicated pins (JTAG and configuration) are powered by V_{CCAUX} (independent of the bank V_{CC0} voltage).

7. Pinout Information and Package

As shown in Table 35, BQR2V6000 device is available in the CCGA1144 packages.

Table 34 BQR2V6000 packages

PIN	NAME	PIN	NAME	PIN	NAME	PIN	NAME
D29	IO_L01N_0	J21	IO_L50P_0	B19	IO_L81N_0	B16	IO_L81P_1
C29	IO_L01P_0	A28	IO_L51N_0	A20	IO_L81P_0/VREF_0	L17	IO_L80N_1
H26	IO_L02N_0	A29	IO_L51P_0/VREF_0	A18	IO_L82N_0	L16	IO_L80P_1
G26	IO_L02P_0	A26	IO_L52N_0	B18	IO_L82P_0	A13	IO_L79N_1
E28	IO_L03N_0/VRP_0	B27	IO_L52P_0	H19	IO_L83N_0	A14	IO_L79P_1
E27	IO_L03P_0/VRN_0	C24	IO_L53N_0	H18	IO_L83P_0	C13	IO_L78N_1
F25	IO_L04N_0/VREF_0	D24	IO_L53P_0	C20	IO_L84N_0	C14	IO_L78P_1
F26	IO_L04P_0	D22	IO_L54N_0	C21	IO_L84P_0	K16	IO_L77N_1
H25	IO_L05N_0	D23	IO_L54P_0	D19	IO_L91N_0/VREF_0	K15	IO_L77P_1
H24	IO_L05P_0	B25	IO_L60N_0	D18	IO_L91P_0	B13	IO_L76N_1
E26	IO_L06N_0	B26	IO_L60P_0	G18	IO_L92N_0	B14	IO_L76P_1
F27	IO_L06P_0	B23	IO_L67N_0	G19	IO_L92P_0	F15	IO_L75N_1/VREF_1
B32	IO_L19N_0	B24	IO_L67P_0	F18	IO_L93N_0	G15	IO_L75P_1
C33	IO_L19P_0	G22	IO_L68N_0	F19	IO_L93P_0	H15	IO_L74N_1
J24	IO_L20N_0	G23	IO_L68P_0	C19	IO_L94N_0/VREF_0	H14	IO_L74P_1
J23	IO_L20P_0	F22	IO_L69N_0	C18	IO_L94P_0	A11	IO_L73N_1
C27	IO_L21N_0	F21	IO_L69P_0/VREF_0	K18	IO_L95N_0/GCLK7P	A12	IO_L73P_1
C28	IO_L21P_0/VREF_0	A23	IO_L70N_0	J18	IO_L95P_0/GCLK6S	E13	IO_L72N_1
B30	IO_L22N_0	A24	IO_L70P_0	E19	IO_L96N_0/GCLK5P	E14	IO_L72P_1
B31	IO_L22P_0	K21	IO_L71N_0	E18	IO_L96P_0/GCLK4S	J15	IO_L71N_1
K23	IO_L23N_0	K20	IO_L71P_0	E17	IO_L96N_1/GCLK3P	J14	IO_L71P_1
K22	IO_L23P_0	C22	IO_L72N_0	E16	IO_L96P_1/GCLK2S	D12	IO_L70N_1
C26	IO_L24N_0	C23	IO_L72P_0	H17	IO_L95N_1/GCLK1P	D13	IO_L70P_1
D27	IO_L24P_0	E21	IO_L73N_0	H16	IO_L95P_1/GCLK0S	F14	IO_L69N_1/VREF_1

PIN	NAME	PIN	NAME	PIN	NAME	PIN	NAME
A30	IO_L25N_0	E22	IO_L73P_0	D17	IO_L94N_1	F13	IO_L69P_1
A31	IO_L25P_0	H21	IO_L74N_0	D16	IO_L94P_1/VREF_1	C11	IO_L68N_1
G24	IO_L26N_0	H20	IO_L74P_0	F16	IO_L93N_1	C12	IO_L68P_1
G25	IO_L26P_0	G20	IO_L75N_0	F17	IO_L93P_1	B11	IO_L67N_1
E25	IO_L27N_0	F20	IO_L75P_0/VREF_0	G16	IO_L92N_1	B12	IO_L67P_1
E24	IO_L27P_0/VREF_0	B21	IO_L76N_0	G17	IO_L92P_1	F11	IO_L60N_1
D25	IO_L28N_0	B22	IO_L76P_0	C16	IO_L91N_1	F12	IO_L60P_1
D26	IO_L28P_0	J20	IO_L77N_0	C15	IO_L91P_1/VREF_1	D10	IO_L54N_1
H23	IO_L29N_0	K19	IO_L77P_0	D14	IO_L84N_1	D11	IO_L54P_1
H22	IO_L29P_0	D20	IO_L78N_0	D15	IO_L84P_1	G12	IO_L53N_1
F23	IO_L30N_0	D21	IO_L78P_0	J17	IO_L83N_1	G13	IO_L53P_1
F24	IO_L30P_0	A21	IO_L79N_0	K17	IO_L83P_1	B9	IO_L52N_1
B28	IO_L49N_0	A22	IO_L79P_0	B17	IO_L82N_1	B10	IO_L52P_1
B29	IO_L49P_0	L19	IO_L80N_0	A17	IO_L82P_1	B8	IO_L51N_1/VREF_1
J22	IO_L50N_0	L18	IO_L80P_0	A15	IO_L81N_1/VREF_1	A9	IO_L51P_1
K14	IO_L50N_1	B3	IO_L01P_1	L8	IO_L44N_2	N2	IO_L75P_2/VREF_2
K13	IO_L50P_1	E2	IO_L01N_2	M8	IO_L44P_2	R4	IO_L76N_2
A6	IO_L49N_1	D2	IO_L01P_2	J1	IO_L45N_2	P4	IO_L76P_2
A7	IO_L49P_1	K11	IO_L02N_2/VRP_2	H2	IO_L45P_2/VREF_2	R8	IO_L77N_2
D9	IO_L30N_1	K10	IO_L02P_2/VRN_2	J3	IO_L46N_2	T8	IO_L77P_2
C9	IO_L30P_1	F5	IO_L03N_2	H3	IO_L46P_2	T3	IO_L78N_2
H13	IO_L29N_1	G5	IO_L03P_2/VREF_2	M9	IO_L47N_2	R3	IO_L78P_2
H12	IO_L29P_1	E3	IO_L04N_2	N9	IO_L47P_2	P1	IO_L79N_2
C7	IO_L28N_1	D3	IO_L04P_2	L5	IO_L48N_2	N1	IO_L79P_2
C8	IO_L28P_1	J9	IO_L05N_2	K5	IO_L48P_2	T11	IO_L80N_2
E11	IO_L27N_1/VREF_1	K9	IO_L05P_2	K2	IO_L49N_2	U11	IO_L80P_2
E10	IO_L27P_1	F4	IO_L06N_2	J2	IO_L49P_2	R7	IO_L81N_2

PIN	NAME	PIN	NAME	PIN	NAME	PIN	NAME
J13	IO_L26N_1	E4	IO_L06P_2	N7	IO_L50N_2	R6	IO_L81P_2/VREF_2
K12	IO_L26P_1	E1	IO_L19N_2	M7	IO_L50P_2	U5	IO_L82N_2
B6	IO_L25N_1	D1	IO_L19P_2	L6	IO_L51N_2	T5	IO_L82P_2
B7	IO_L25P_1	J8	IO_L20N_2	M6	IO_L51P_2/VREF_2	T10	IO_L83N_2
E8	IO_L24N_1	K8	IO_L20P_2	M3	IO_L52N_2	U10	IO_L83P_2
E9	IO_L24P_1	H7	IO_L21N_2	L3	IO_L52P_2	U4	IO_L84N_2
G10	IO_L23N_1	J7	IO_L21P_2/VREF_2	L4	IO_L53N_2	T4	IO_L84P_2
G11	IO_L23P_1	H6	IO_L22N_2	K4	IO_L53P_2	T2	IO_L91N_2
A4	IO_L22N_1	G6	IO_L22P_2	N4	IO_L54N_2	R1	IO_L91P_2
A5	IO_L22P_1	L10	IO_L23N_2	M4	IO_L54P_2	U7	IO_L92N_2
F10	IO_L21N_1/VREF_1	L9	IO_L23P_2	M2	IO_L67N_2	T7	IO_L92P_2
G9	IO_L21P_1	G3	IO_L24N_2	L2	IO_L67P_2	T6	IO_L93N_2
J12	IO_L20N_1	F3	IO_L24P_2	N8	IO_L68N_2	U6	IO_L93P_2/VREF_2
J11	IO_L20P_1	G2	IO_L25N_2	P8	IO_L68P_2	U1	IO_L94N_2
B4	IO_L19N_1	F2	IO_L25P_2	N6	IO_L69N_2	U2	IO_L94P_2
B5	IO_L19P_1	M10	IO_L26N_2	P6	IO_L69P_2/VREF_2	U9	IO_L95N_2
D6	IO_L06N_1	N10	IO_L26P_2	P5	IO_L70N_2	U8	IO_L95P_2
C6	IO_L06P_1	J6	IO_L27N_2	N5	IO_L70P_2	U3	IO_L96N_2
H11	IO_L05N_1	K6	IO_L27P_2/VREF_2	P10	IO_L71N_2	V4	IO_L96P_2
J10	IO_L05P_1	J5	IO_L28N_2	R10	IO_L71P_2	V6	IO_L96N_3
D8	IO_L04N_1	H5	IO_L28P_2	P3	IO_L72N_2	W6	IO_L96P_3
E7	IO_L04P_1/VREF_1	L7	IO_L29N_2	N3	IO_L72P_2	V5	IO_L95N_3
F9	IO_L03N_1/VRP_1	K7	IO_L29P_2	M1	IO_L73N_2	W5	IO_L95P_3
F8	IO_L03P_1/VRN_1	J4	IO_L30N_2	L1	IO_L73P_2	V7	IO_L94N_3
H10	IO_L02N_1	H4	IO_L30P_2	P9	IO_L74N_2	W7	IO_L94P_3
H9	IO_L02P_1	G1	IO_L43N_2	R9	IO_L74P_2	V10	IO_L93N_3/VREF_3
C2	IO_L01N_1	F1	IO_L43P_2	P2	IO_L75N_2	W10	IO_L93P_3

PIN	NAME	PIN	NAME	PIN	NAME	PIN	NAME
K14	IO_L50N_1	B3	IO_L01P_1	L8	IO_L44N_2	N2	IO_L75P_2/VREF_2
K13	IO_L50P_1	E2	IO_L01N_2	M8	IO_L44P_2	R4	IO_L76N_2
A6	IO_L49N_1	D2	IO_L01P_2	J1	IO_L45N_2	P4	IO_L76P_2
V1	IO_L92N_3	AD4	IO_L67P_3	AH3	IO_L23N_3	AH10	IO_L21P_4/VREF_4
V2	IO_L92P_3	AB7	IO_L54N_3	AJ3	IO_L23P_3	AN5	IO_L22N_4
W3	IO_L91N_3	AC7	IO_L54P_3	AF7	IO_L22N_3	AN4	IO_L22P_4
Y3	IO_L91P_3	AC2	IO_L53N_3	AG7	IO_L22P_3	AE12	IO_L23N_4
V9	IO_L84N_3	AD2	IO_L53P_3	AL1	IO_L21N_3/VREF_3	AE13	IO_L23P_4
V8	IO_L84P_3	AC8	IO_L52N_3	AK1	IO_L21P_3	AM9	IO_L24N_4
W4	IO_L83N_3	AB8	IO_L52P_3	AH2	IO_L20N_3	AL8	IO_L24P_4
Y4	IO_L83P_3	AB10	IO_L51N_3/VREF_3	AJ2	IO_L20P_3	AP5	IO_L25N_4
W11	IO_L82N_3	AC10	IO_L51P_3	AJ4	IO_L19N_3	AP4	IO_L25P_4
V11	IO_L82P_3	AD5	IO_L50N_3	AK4	IO_L19P_3	AG11	IO_L26N_4
W8	IO_L81N_3/VREF_3	AE5	IO_L50P_3	AE10	IO_L06N_3	AG12	IO_L26P_4
Y8	IO_L81P_3	AE4	IO_L49N_3	AD10	IO_L06P_3	AN7	IO_L27N_4
W2	IO_L80N_3	AF4	IO_L49P_3	AK2	IO_L05N_3	AN6	IO_L27P_4/VREF_4
Y1	IO_L80P_3	AB9	IO_L48N_3	AL2	IO_L05P_3	AL10	IO_L28N_4
AA3	IO_L79N_3	AC9	IO_L48P_3	AH6	IO_L04N_3	AL9	IO_L28P_4
AB3	IO_L79P_3	AE2	IO_L47N_3	AJ5	IO_L04P_3	AF12	IO_L29N_4
Y6	IO_L78N_3	AF1	IO_L47P_3	AE11	IO_L03N_3/VREF_3	AF13	IO_L29P_4
AA6	IO_L78P_3	AD6	IO_L46N_3	AF11	IO_L03P_3	AK10	IO_L30N_4
AA4	IO_L77N_3	AE6	IO_L46P_3	AK3	IO_L02N_3/VRP_3	AK11	IO_L30P_4
AB4	IO_L77P_3	AD9	IO_L45N_3/VREF_3	AL3	IO_L02P_3/VRN_3	AP7	IO_L49N_4
Y7	IO_L76N_3	AE9	IO_L45P_3	AF10	IO_L01N_3	AP6	IO_L49P_4
AA8	IO_L76P_3	AF2	IO_L44N_3	AG9	IO_L01P_3	AH13	IO_L50N_4
Y10	IO_L75N_3/VREF_3	AG2	IO_L44P_3	AM4	IO_L01N_4/DOUT	AH12	IO_L50P_4

PIN	NAME	PIN	NAME	PIN	NAME	PIN	NAME
AA10	IO_L75P_3	AF3	IO_L43N_3	AL5	IO_L01P_4/INIT_B	AJ11	IO_L51N_4
AA1	IO_L74N_3	AG3	IO_L43P_3	AG10	IO_L02N_4/D0	AJ12	IO_L51P_4/VREF_4
AB1	IO_L74P_3	AD7	IO_L30N_3	AH11	IO_L02P_4/D1	AP9	IO_L52N_4
AA5	IO_L73N_3	AE7	IO_L30P_3	AK7	IO_L03N_4/D2/ALT_VRP_4	AN8	IO_L52P_4
AB5	IO_L73P_3	AF5	IO_L29N_3	AK8	IO_L03P_4/D3/ALT_VRN_4	AG13	IO_L53N_4
AA9	IO_L72N_3	AG5	IO_L29P_3	AL6	IO_L04N_4/VREF_4	AG14	IO_L53P_4
Y9	IO_L72P_3	AE8	IO_L28N_3	AM6	IO_L04P_4	AM11	IO_L54N_4
AA2	IO_L71N_3	AD8	IO_L28P_3	AK9	IO_L05N_4/VRP_4	AL11	IO_L54P_4
AB2	IO_L71P_3	AF8	IO_L27N_3/VREF_3	AJ8	IO_L05P_4/VRN_4	AN10	IO_L60N_4
AB6	IO_L70N_3	AF9	IO_L27P_3	AM8	IO_L06N_4	AN9	IO_L60P_4
AC6	IO_L70P_3	AH1	IO_L26N_3	AM7	IO_L06P_4	AN12	IO_L67N_4
AD1	IO_L69N_3/VREF_3	AJ1	IO_L26P_3	AN3	IO_L19N_4	AN11	IO_L67P_4
AC1	IO_L69P_3	AG4	IO_L25N_3	AM2	IO_L19P_4	AE14	IO_L68N_4
AC3	IO_L68N_3	AH5	IO_L25P_3	AJ10	IO_L20N_4	AE15	IO_L68P_4
AD3	IO_L68P_3	AF6	IO_L24N_3	AJ9	IO_L20P_4	AJ13	IO_L69N_4
AC4	IO_L67N_3	AG6	IO_L24P_3	AH9	IO_L21N_4	AJ14	IO_L69P_4/VREF_4
V1	IO_L92N_3	AD4	IO_L67P_3	AH3	IO_L23N_3	AH10	IO_L21P_4/VREF_4
V2	IO_L92P_3	AB7	IO_L54N_3	AJ3	IO_L23P_3	AN5	IO_L22N_4
W3	IO_L91N_3	AC7	IO_L54P_3	AF7	IO_L22N_3	AN4	IO_L22P_4
AL13	IO_L70N_4	AM17	IO_L94P_4	AG19	IO_L74N_5	AH25	IO_L27P_5
AL12	IO_L70P_4	AF17	IO_L95N_4/GCLK3S	AG20	IO_L74P_5	AF22	IO_L26N_5
AF14	IO_L71N_4	AG17	IO_L95P_4/GCLK2P	AP24	IO_L73N_5	AF23	IO_L26P_5
AF15	IO_L71P_4	AK16	IO_L96N_4/GCLK1S	AP23	IO_L73P_5	AM27	IO_L25N_5

PIN	NAME	PIN	NAME	PIN	NAME	PIN	NAME
AM13	IO_L72N_4	AK17	IO_L96P_4/GCLK0 P	AL23	IO_L72N_5	AM26	IO_L25P_5
AM12	IO_L72P_4	AK18	IO_L96N_5/GCLK 7S	AL22	IO_L72P_5	AL27	IO_L24N_5
AP12	IO_L73N_4	AK19	IO_L96P_5/GCLK6 P	AF20	IO_L71N_5	AL26	IO_L24P_5
AP11	IO_L73P_4	AG18	IO_L95N_5/GCLK 5S	AF21	IO_L71P_5	AH26	IO_L23N_5
AG15	IO_L74N_4	AF18	IO_L95P_5/GCLK4 P	AM24	IO_L70N_5	AJ25	IO_L23P_5
AG16	IO_L74P_4	AL18	IO_L94N_5	AM23	IO_L70P_5	AN31	IO_L22N_5
AN14	IO_L75N_4	AL19	IO_L94P_5/VREF_ 5	AJ21	IO_L69N_5/VREF_5	AN30	IO_L22P_5
AN13	IO_L75P_4/VREF_4	AJ19	IO_L93N_5	AJ22	IO_L69P_5	AK26	IO_L21N_5/VREF_ 5
AP14	IO_L76N_4	AJ18	IO_L93P_5	AJ24	IO_L68N_5	AK27	IO_L21P_5
AP13	IO_L76P_4	AH19	IO_L92N_5	AJ23	IO_L68P_5	AG23	IO_L20N_5
AD16	IO_L77N_4	AH18	IO_L92P_5	AN24	IO_L67N_5	AF24	IO_L20P_5
AD17	IO_L77P_4	AM19	IO_L91N_5	AN23	IO_L67P_5	AM33	IO_L19N_5
AK14	IO_L78N_4	AM20	IO_L91P_5/VREF_ 5	AN26	IO_L60N_5	AN32	IO_L19P_5
AK13	IO_L78P_4	AL21	IO_L84N_5	AN25	IO_L60P_5	AJ27	IO_L06N_5
AN16	IO_L79N_4	AL20	IO_L84P_5	AL25	IO_L54N_5	AJ26	IO_L06P_5
AP15	IO_L79P_4	AM22	IO_L83N_5	AL24	IO_L54P_5	AE22	IO_L05N_5/VRP_5
AE16	IO_L80N_4	AM21	IO_L83P_5	AE20	IO_L53N_5	AE23	IO_L05P_5/VRN_5
AE17	IO_L80P_4	AN18	IO_L82N_5	AE21	IO_L53P_5	AM28	IO_L04N_5
AH15	IO_L81N_4	AP18	IO_L82P_5	AN27	IO_L52N_5	AM29	IO_L04P_5/VREF_ 5
AJ15	IO_L81P_4/VREF_4	AP20	IO_L81N_5/VREF_ 5	AP26	IO_L52P_5	AK28	IO_L03N_5/D4/AL T_VRP_5
AP17	IO_L82N_4	AN19	IO_L81P_5	AP29	IO_L51N_5/VREF_5	AL29	IO_L03P_5/D5/ALT _VRN_5
AN17	IO_L82P_4	AE18	IO_L80N_5	AP28	IO_L51P_5	AG24	IO_L02N_5/D6

PIN	NAME	PIN	NAME	PIN	NAME	PIN	NAME
AH17	IO_L83N_4	AE19	IO_L80P_5	AG21	IO_L50N_5	AG25	IO_L02P_5/D7
AH16	IO_L83P_4	AP22	IO_L79N_5	AG22	IO_L50P_5	AL30	IO_L01N_5/RDWR _B
AL15	IO_L84N_4	AP21	IO_L79P_5	AN29	IO_L49N_5	AM31	IO_L01P_5/CS_B
AL14	IO_L84P_4	AK22	IO_L78N_5	AN28	IO_L49P_5	AE24	IO_L01P_6
AL16	IO_L91N_4/VREF_ 4	AK21	IO_L78P_5	AK24	IO_L30N_5	AD25	IO_L01N_6
AL17	IO_L91P_4	AD18	IO_L77N_5	AK25	IO_L30P_5	AJ30	IO_L02P_6/VRN_6
AJ17	IO_L92N_4	AD19	IO_L77P_5	AH23	IO_L29N_5	AH30	IO_L02N_6/VRP_6
AJ16	IO_L92P_4	AN22	IO_L76N_5	AH22	IO_L29P_5	AL32	IO_L03P_6
AM15	IO_L93N_4	AN21	IO_L76P_5	AP31	IO_L28N_5	AK32	IO_L03N_6/VREF_ 6
AM14	IO_L93P_4	AJ20	IO_L75N_5/VREF_ 5	AP30	IO_L28P_5	AF25	IO_L04P_6
AM16	IO_L94N_4/VREF_ 4	AH20	IO_L75P_5	AH24	IO_L27N_5/VREF_5	AE25	IO_L04N_6
AL13	IO_L70N_4	AM17	IO_L94P_4	AG19	IO_L74N_5	AH25	IO_L27P_5
AL12	IO_L70P_4	AF17	IO_L95N_4/GCLK 3S	AG20	IO_L74P_5	AF22	IO_L26N_5
AF14	IO_L71N_4	AG17	IO_L95P_4/GCLK2 P	AP24	IO_L73N_5	AF23	IO_L26P_5
AJ31	IO_L05P_6	AH34	IO_L47N_6	AA30	IO_L78P_6	U30	IO_L91N_7
AK31	IO_L05N_6	AE30	IO_L48P_6	AB30	IO_L78N_6	R32	IO_L84P_7
AH29	IO_L06P_6	AD30	IO_L48N_6	W24	IO_L79P_6	T32	IO_L84N_7
AG29	IO_L06N_6	AC26	IO_L49P_6	V24	IO_L79N_6	U25	IO_L83P_7
AG26	IO_L19P_6	AB26	IO_L49N_6	AB34	IO_L80P_6	T25	IO_L83N_7
AF26	IO_L19N_6	AD29	IO_L50P_6	AA34	IO_L80N_6	R34	IO_L82P_7
AL33	IO_L20P_6	AC29	IO_L50N_6	W33	IO_L81P_6	T33	IO_L82N_7
AK33	IO_L20N_6	AF33	IO_L51P_6	Y34	IO_L81N_6/VREF_6	N34	IO_L81P_7/VREF_ 7
AJ32	IO_L21P_6	AG33	IO_L51N_6/VREF_ 6	W25	IO_L82P_6	P34	IO_L81N_7

PIN	NAME	PIN	NAME	PIN	NAME	PIN	NAME
AH32	IO_L21N_6/VREF_6	AC28	IO_L52P_6	V25	IO_L82N_6	U24	IO_L80P_7
AG28	IO_L22P_6	AB28	IO_L52N_6	Y32	IO_L83P_6	T24	IO_L80N_7
AF28	IO_L22N_6	AF34	IO_L53P_6	AA32	IO_L83N_6	R31	IO_L79P_7
AG30	IO_L23P_6	AE33	IO_L53N_6	W29	IO_L84P_6	T31	IO_L79N_7
AF30	IO_L23N_6	AB27	IO_L54P_6	V29	IO_L84N_6	N32	IO_L78P_7
AF29	IO_L24P_6	AA27	IO_L54N_6	W28	IO_L91P_6	P32	IO_L78N_7
AE29	IO_L24N_6	AA25	IO_L67P_6	V28	IO_L91N_6	T27	IO_L77P_7
AF27	IO_L25P_6	Y25	IO_L67N_6	V33	IO_L92P_6	R27	IO_L77N_7
AE27	IO_L25N_6	AD33	IO_L68P_6	V34	IO_L92N_6	N33	IO_L76P_7
AL34	IO_L26P_6	AC33	IO_L68N_6	Y31	IO_L93P_6	P33	IO_L76N_7
AK34	IO_L26N_6	AC32	IO_L69P_6	W31	IO_L93N_6/VREF_6	R29	IO_L75P_7/VREF_7
AE28	IO_L27P_6	AB32	IO_L69N_6/VREF_6	V26	IO_L94P_6	R28	IO_L75N_7
AD28	IO_L27N_6/VREF_6	AA26	IO_L70P_6	V27	IO_L94N_6	R26	IO_L74P_7
AE26	IO_L28P_6	Y26	IO_L70N_6	W30	IO_L95P_6	P26	IO_L74N_7
AD26	IO_L28N_6	AD34	IO_L71P_6	V30	IO_L95N_6	N31	IO_L73P_7
AF31	IO_L29P_6	AC34	IO_L71N_6	V32	IO_L96P_6	P31	IO_L73N_7
AG31	IO_L29N_6	AC31	IO_L72P_6	W32	IO_L96N_6	N30	IO_L72P_7
AF32	IO_L30P_6	AD31	IO_L72N_6	U31	IO_L96P_7	P30	IO_L72N_7
AG32	IO_L30N_6	Y27	IO_L73P_6	V31	IO_L96N_7	R25	IO_L71P_7
AC25	IO_L43P_6	W27	IO_L73N_6	T28	IO_L95P_7	P25	IO_L71N_7
AB25	IO_L43N_6	AB29	IO_L74P_6	U28	IO_L95N_7	L34	IO_L70P_7
AJ33	IO_L44P_6	AA29	IO_L74N_6	U33	IO_L94P_7	M34	IO_L70N_7
AH33	IO_L44N_6	AB31	IO_L75P_6	U34	IO_L94N_7	P29	IO_L69P_7/VREF_7
AE31	IO_L45P_6	AA31	IO_L75N_6/VREF_6	U29	IO_L93P_7/VREF_7	N29	IO_L69N_7
AD32	IO_L45N_6/VREF_6	Y28	IO_L76P_6	T29	IO_L93N_7	P27	IO_L68P_7
AD27	IO_L46P_6	Y29	IO_L76N_6	U27	IO_L92P_7	N27	IO_L68N_7

PIN	NAME	PIN	NAME	PIN	NAME	PIN	NAME
AC27	IO_L46N_6	AB33	IO_L77P_6	U26	IO_L92N_7	L32	IO_L67P_7
AJ34	IO_L47P_6	AA33	IO_L77N_6	T30	IO_L91P_7	M32	IO_L67N_7
AJ31	IO_L05P_6	AH34	IO_L47N_6	AA30	IO_L78P_6	U30	IO_L91N_7
AK31	IO_L05N_6	AE30	IO_L48P_6	AB30	IO_L78N_6	R32	IO_L84P_7
AH29	IO_L06P_6	AD30	IO_L48N_6	W24	IO_L79P_6	T32	IO_L84N_7
L31	IO_L54P_7	K26	IO_L23N_7	L15	VCCO_1	AD14	VCCO_4
M31	IO_L54N_7	F33	IO_L22P_7	L14	VCCO_1	AD13	VCCO_4
K29	IO_L53P_7	G33	IO_L22N_7	L13	VCCO_1	AD12	VCCO_4
L30	IO_L53N_7	J28	IO_L21P_7/VREF_7	L12	VCCO_1	AC17	VCCO_4
L33	IO_L52P_7	J27	IO_L21N_7	E15	VCCO_1	AC16	VCCO_4
M33	IO_L52N_7	K27	IO_L20P_7	D7	VCCO_1	AC15	VCCO_4
M29	IO_L51P_7/VREF_7	J26	IO_L20N_7	A16	VCCO_1	AC14	VCCO_4
L29	IO_L51N_7	E31	IO_L19P_7	A10	VCCO_1	AC13	VCCO_4
M28	IO_L50P_7	F31	IO_L19N_7	U12	VCCO_2	AP25	VCCO_5
N28	IO_L50N_7	D32	IO_L06P_7	T12	VCCO_2	AP19	VCCO_5
K30	IO_L49P_7	E32	IO_L06N_7	T1	VCCO_2	AL28	VCCO_5
K31	IO_L49N_7	L25	IO_L05P_7	R12	VCCO_2	AK20	VCCO_5
H32	IO_L48P_7	K24	IO_L05N_7	R11	VCCO_2	AD23	VCCO_5
J32	IO_L48N_7	D34	IO_L04P_7	R5	VCCO_2	AD22	VCCO_5
N26	IO_L47P_7	E34	IO_L04N_7	P12	VCCO_2	AD21	VCCO_5
M26	IO_L47N_7	G30	IO_L03P_7/VREF_7	P11	VCCO_2	AD20	VCCO_5
J33	IO_L46P_7	F30	IO_L03N_7	N12	VCCO_2	AC22	VCCO_5
K33	IO_L46N_7	K25	IO_L02P_7/VRN_7	N11	VCCO_2	AC21	VCCO_5
H33	IO_L45P_7/VREF_7	J25	IO_L02N_7/VRP_7	M11	VCCO_2	AC20	VCCO_5
J34	IO_L45N_7	D33	IO_L01P_7	K1	VCCO_2	AC19	VCCO_5
M27	IO_L44P_7	E33	IO_L01N_7	G4	VCCO_2	AC18	VCCO_5
L27	IO_L44N_7	M22	VCCO_0	AH4	VCCO_3	AH31	VCCO_6
H31	IO_L43P_7	M21	VCCO_0	AE1	VCCO_3	AE34	VCCO_6
J31	IO_L43N_7	M20	VCCO_0	AC11	VCCO_3	AC24	VCCO_6
F32	IO_L30P_7	M19	VCCO_0	AB12	VCCO_3	AB24	VCCO_6
G32	IO_L30N_7	M18	VCCO_0	AB11	VCCO_3	AB23	VCCO_6

PIN	NAME	PIN	NAME	PIN	NAME	PIN	NAME
N25	IO_L29P_7	L23	VCCO_0	AA12	VCCO_3	AA24	VCCO_6
M25	IO_L29N_7	L22	VCCO_0	AA11	VCCO_3	AA23	VCCO_6
F34	IO_L28P_7	L21	VCCO_0	Y12	VCCO_3	Y30	VCCO_6
G34	IO_L28N_7	L20	VCCO_0	Y11	VCCO_3	Y24	VCCO_6
J30	IO_L27P_7/VREF_7	E20	VCCO_0	Y5	VCCO_3	Y23	VCCO_6
H30	IO_L27N_7	D28	VCCO_0	W12	VCCO_3	W34	VCCO_6
K28	IO_L26P_7	A25	VCCO_0	W1	VCCO_3	W23	VCCO_6
L28	IO_L26N_7	A19	VCCO_0	V12	VCCO_3	V23	VCCO_6
H28	IO_L25P_7	M17	VCCO_1	AP16	VCCO_4	U23	VCCO_7
J29	IO_L25N_7	M16	VCCO_1	AP10	VCCO_4	T34	VCCO_7
G29	IO_L24P_7	M15	VCCO_1	AL7	VCCO_4	T23	VCCO_7
H29	IO_L24N_7	M14	VCCO_1	AK15	VCCO_4	R30	VCCO_7
L26	IO_L23P_7	M13	VCCO_1	AD15	VCCO_4	R24	VCCO_7
L31	IO_L54P_7	K26	IO_L23N_7	L15	VCCO_1	AD14	VCCO_4
M31	IO_L54N_7	F33	IO_L22P_7	L14	VCCO_1	AD13	VCCO_4
K29	IO_L53P_7	G33	IO_L22N_7	L13	VCCO_1	AD12	VCCO_4
R23	VCCO_7	AB19	VCCINT	AP8	GND	AA17	GND
P24	VCCO_7	AB18	VCCINT	AP3	GND	AA16	GND
P23	VCCO_7	AB17	VCCINT	AN33	GND	AA15	GND
N24	VCCO_7	AB16	VCCINT	AN20	GND	AA14	GND
N23	VCCO_7	AB15	VCCINT	AN15	GND	AA7	GND
M24	VCCO_7	AB14	VCCINT	AN2	GND	Y33	GND
K34	VCCO_7	AB13	VCCINT	AM34	GND	Y21	GND
G31	VCCO_7	AA22	VCCINT	AM32	GND	Y20	GND
AH8	CCLK	AA13	VCCINT	AM25	GND	Y19	GND
D30	PROG_B	Y22	VCCINT	AM10	GND	Y18	GND
AJ7	DONE	Y13	VCCINT	AM3	GND	Y17	GND
AH27	M0	W22	VCCINT	AM1	GND	Y16	GND
AJ28	M1	W13	VCCINT	AL31	GND	Y15	GND
AK29	M2	V22	VCCINT	AL4	GND	Y14	GND
E29	HSWAP_EN	V13	VCCINT	AK30	GND	Y2	GND
F7	TCK	U22	VCCINT	AK23	GND	W26	GND
C31	TDI	U13	VCCINT	AK12	GND	W21	GND

PIN	NAME	PIN	NAME	PIN	NAME	PIN	NAME
D5	TDO	T22	VCCINT	AK5	GND	W20	GND
E6	TMS	T13	VCCINT	AJ29	GND	W19	GND
AK6	PWRDWN_B	R22	VCCINT	AJ6	GND	W18	GND
F28	DXN	R13	VCCINT	AH28	GND	W17	GND
G27	DXP	P22	VCCINT	AH21	GND	W16	GND
C4	VBATT	P13	VCCINT	AH14	GND	W15	GND
G8	RSVD	N22	VCCINT	AH7	GND	W14	GND
AM30	VCCAUX	N21	VCCINT	AG34	GND	W9	GND
AM18	VCCAUX	N20	VCCINT	AG27	GND	V21	GND
AM5	VCCAUX	N19	VCCINT	AG8	GND	V20	GND
V3	VCCAUX	N18	VCCINT	AG1	GND	V19	GND
U32	VCCAUX	N17	VCCINT	AF19	GND	V18	GND
C30	VCCAUX	N16	VCCINT	AF16	GND	V17	GND
C17	VCCAUX	N15	VCCINT	AE32	GND	V16	GND
C5	VCCAUX	N14	VCCINT	AE3	GND	V15	GND
AD24	VCCINT	N13	VCCINT	AC30	GND	V14	GND
AD11	VCCINT	M23	VCCINT	AC5	GND	U21	GND
AC23	VCCINT	M12	VCCINT	AA28	GND	U20	GND
AC12	VCCINT	L24	VCCINT	AA21	GND	U19	GND
AB22	VCCINT	L11	VCCINT	AA20	GND	U18	GND
AB21	VCCINT	AP32	GND	AA19	GND	U17	GND
AB20	VCCINT	AP27	GND	AA18	GND	U16	GND
R23	VCCO_7	AB19	VCCINT	AP8	GND	AA17	GND
P24	VCCO_7	AB18	VCCINT	AP3	GND	AA16	GND
P23	VCCO_7	AB17	VCCINT	AN33	GND	AA15	GND
U15	GND	R17	GND	K32	GND	E5	GND
U14	GND	R16	GND	K3	GND	D31	GND
T26	GND	R15	GND	J19	GND	D4	GND
T21	GND	R14	GND	J16	GND	C34	GND
T20	GND	R2	GND	H34	GND	C32	GND
T19	GND	P28	GND	H27	GND	C25	GND
T18	GND	P21	GND	H8	GND	C10	GND
T17	GND	P20	GND	H1	GND	C3	GND

PIN	NAME	PIN	NAME	PIN	NAME	PIN	NAME
T16	GND	P19	GND	G28	GND	C1	GND
T15	GND	P18	GND	G21	GND	B33	GND
T14	GND	P17	GND	G14	GND	B20	GND
T9	GND	P16	GND	G7	GND	B15	GND
R33	GND	P15	GND	F29	GND	B2	GND
R21	GND	P14	GND	F6	GND	A32	GND
R20	GND	P7	GND	E30	GND	A27	GND
R19	GND	M30	GND	E23	GND	A8	GND
R18	GND	M5	GND	E12	GND	A3	GND

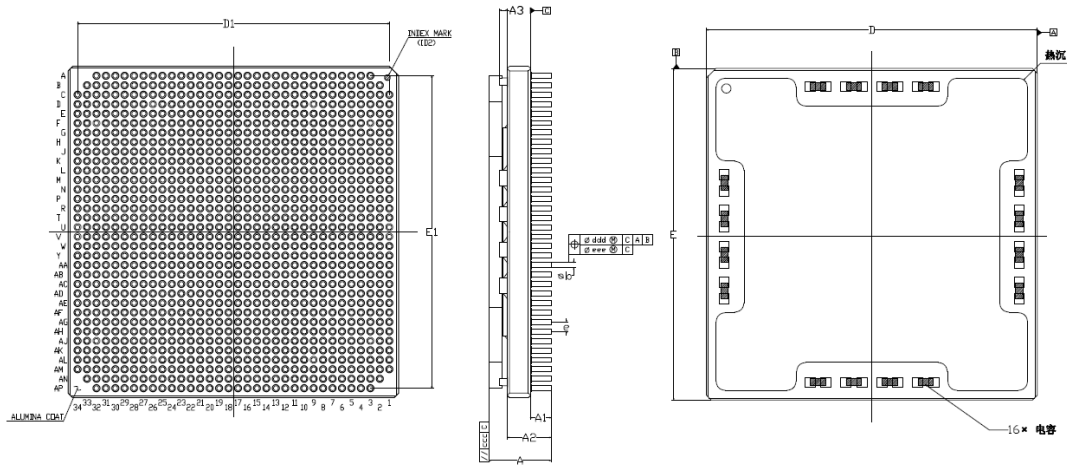

SYMBOL	MILLIMETERS (Unit:mm)		
	MIN	NOM	MAX
A	6.30	6.65	7.00
A1	2.05	2.20	2.35
A2	4.21	4.60	4.99
A3	0.55	—	0.9
D/E	34.00	35.00	36.00
D1/E1	32.00	33.00	34.00
e	—	1.00	—
Ø b	0.46	0.51	0.56
ccc	—	—	0.35
ddd	—	—	0.30

<i>Eee</i>	—	—	0.10
NOTE : Millimeters which is not mentioned above conform to Table 1 in GB/T1804-2000			

Appendix I Electrical performance characteristics

Table I-1: Electrical performance characteristics

Test	Symbol	Conditions Limits $1.425V \leq V_{CCINT} \leq 1.575V$, $3.0V \leq V_{CC0} \leq 3.6V$, $3.0V \leq V_{CCAUX} \leq 3.6V$, $-55^{\circ}C \leq T_A \leq 125^{\circ}C$	Group A Subgroups	Limits		units
				Min	Max	
Data retention VCCINT voltage below which, configuration may be lost	V_{DRINT}		A1, A2, A3	1.2	—	V
Data retention VCCAUX voltage below which configuration may be lost	V_{DRI}		A1, A2, A3	2.5	—	V
High-level input voltage	V_{IH}	lvttl	A1, A2, A3	2.0	—	V
High-level input voltage	V_{IH}	lvds	A1, A2, A3	1.425	—	V
High-level input voltage Low	V_{IH}	lvds	A1, A2, A3	0.25	—	V
High-level input voltage Med	V_{IH}	lvds	A1, A2, A3	1.625	—	V
High-level input voltage High	V_{IH}	lvds	A1, A2, A3	2.5	—	V
High-level input voltage	V_{IH}	ldt	A1, A2, A3	1.425	—	V
High-level input voltage Low	V_{IH}	sstl	A1, A2, A3	0.7	—	V
High-level input voltage Med	V_{IH}	sstl	A1, A2, A3	1.2	—	V



Test	Symbol	Conditions Limits 1.425V ≤ V _{CCINT} ≤ 1.575V, 3.0V ≤ V _{CCO} ≤ 3.6V, 3.0V ≤ V _{CCAUX} ≤ 3.6V, -55°C ≤ T _A ≤ 125°C	Group A Subgroups	Limits		units
				Min	Max	
High-level input voltage High	V _{IH}	sstl	A1, A2, A3	1.7	—	V
Low-level input voltage	V _{IL}	lvttl	A1, A2, A3	—	0.8	V
Low-level input voltage	V _{IL}	lvds	A1, A2, A3	—	1.025	V
Low-level input voltage Low	V _{IL}	lvds	A1, A2, A3	—	0.0	V
Low-level input voltage Med	V _{IL}	lvds	A1, A2, A3	—	1.375	V
Low-level input voltage High	V _{IL}	lvds	A1, A2, A3	—	2.25	V
Low-level input voltage	V _{IL}	ldt	A1, A2, A3	—	1.025	V
Low-level input voltage Low	V _{IL}	sstl	A1, A2, A3	—	0.5	V
Low-level input voltage Med	V _{IL}	sstl	A1, A2, A3	—	1.0	V
Low-level input voltage High	V _{IL}	sstl	A1, A2, A3	—	1.5	V
High-level output voltage	V _{OH}	I _{OH} = -1.75, -3.5, -4, -8 or -12mA (ttl2, ttl4,ttl8,ttl16,ttl24), V _{CCO} = 3.0V V _{CCINT} = 1.425V	A1, A2, A3	2.4	—	V
Low-level output voltage	V _{OL}	I _{OL} = 8, or 12 mA (ttl16, ttl24) V _{CCO} = 3.0V, V _{CCINT} = 1.425V	A1, A2, A3	—	0.45	V

Test	Symbol	Conditions Limits 1.425V ≤ V _{CCINT} ≤ 1.575V, 3.0V ≤ V _{CCO} ≤ 3.6V, 3.0V ≤ V _{CCAUX} ≤ 3.6V, -55°C ≤ T _A ≤ 125°C	Group A Subgroups	Limits		units
				Min	Max	
Quiescent VCCINT Supply current	I _{CCINTQ}		A1, A2, A3	—	500	mA
Quiescent VCCO Supply current	I _{CCOQ}		A1, A2, A3	—	6.25	mA
Quiescent VCCAUX Supply current	I _{CCAUXQ}		A1, A2, A3	—	95	mA
Input or output leakage current	I _L		A1, A2, A3	-10	10	μA
VREF current per bank	I _{REF}		A1, A2, A3	-10	10	μA
Pad pull-up (when selected)	I _{RPU}	V _{IN} = 0V V _{CCO} = 3.3 V	A1, A2, A3	—	0.25	mA
Pad pull-down (when selected)	I _{RPD}	V _{IN} = 3.6V V _{CCO} = 3.6 V	A1, A2, A3	—	0.25	mA
Battery supply current	I _{BATT}		A1, A2, A3		100	nA
Minimum required current supply	I _{CCINTMIN}		A1, A2, A3	1300		mA
Minimum required current supply	I _{CCAUXMIN}		A1, A2, A3	95		mA
Minimum required current supply	I _{CCOMIN}		A1, A2, A3	6.25		mA
Functional test	f		A7, A8A, A8B	—	—	—

Test	Symbol	Conditions Limits 1.425V≤V _{CCINT} ≤1.575V, 3.0V≤V _{CCO} ≤3.6V, 3.0V≤V _{CCAUX} ≤3.6V, -55℃≤T _A ≤125℃	Group A Subgroups	Limits		units
				Min	Max	
Input capacitance (sample tested)	C _{in} , C _{out}	f=1.0MHz, V _{OUT} =0V	A4	—	20	pF
CLK0, CLK90, CLK190, CLK270	CLKOUT_FREQ_1X_ LF_Min		A9, A10, A11	24	—	MHz
CLK0, CLK90, CLK190, CLK270	CLKOUT_FREQ_1X_ LF_Max		A9, A10, A11	—	180	MHz
CLK2X, CLK2X180	CLKOUT_FREQ_2X_ LF_Min		A9, A10, A11	48	—	MHz
CLK2X, CLK2X180	CLKOUT_FREQ_2X_ LF_Max		A9, A10, A11	—	360	MHz
CLKDV	CLKOUT_FREQ_DV_ LF_Min		A9, A10, A11	1.5	—	MHz
CLKDV	CLKOUT_FREQ_DV_ LF_Max		A9, A10, A11	—	120	MHz
CLKFX, CLKFX180	CLKOUT_FREQ_FX_ LF_Min		A9, A10, A11	24	—	MHz
CLKFX, CLKFX180	CLKOUT_FREQ_FX_ LF_Max		A9, A10, A11	—	210	MHz
CLKIN (using DLL outputs)	CLKIN_FREQ_DLL_ LF_Min		A9, A10, A11	24		MHz
CLKIN (using DLL outputs)	CLKIN_FREQ_DLL_ LF_Max		A9, A10, A11		180.0 0	MHz
CLKIN(using CLKFX outputs)	CLKIN_FREQ_FX_ LF_Min		A9, A10, A11	1.00		MHz

Test	Symbol	Conditions Limits 1.425V≤V _{CCINT} ≤1.575V, 3.0V≤V _{CCO} ≤3.6V, 3.0V≤V _{CCAUX} ≤3.6V, -55℃≤T _A ≤125℃	Group A Subgroups	Limits		units
				Min	Max	
CLKIN (using CLKFX outputs)	<i>CLKIN_FREQ_FX_LF_Max</i>		A9, A10, A11		210.0 0	MHz
CLKI0, CLK180	<i>CLKOUT_FREQ_IX_HF_Min</i>		A9, A10, A11	48	—	MHz
CLKI0, CLK180	<i>CLKOUT_FREQ_IX_HF_Max</i>		A9, A10, A11	—	360	MHz
CLKDV	<i>CLKOUT_FREQ_DV_HF_Min</i>		A9, A10, A11	3	—	MHz
CLKDV	<i>CLKOUT_FREQ_DV_HF_Max</i>		A9, A10, A11	—	240	MHz
CLKFX, CLKFX180	<i>CLKOUT_FREQ_FX_HF_Min</i>		A9, A10, A11	210	—	MHz
CLKFX, CLKFX180	<i>CLKOUT_FREQ_FX_HF_Max</i>		A9, A10, A11	—	270	MHz
CLKIN (using DLLoutputs)	<i>CLKIN_FREQ_DLL_HF_Min</i>		A9, A10, A11	48		MHz
CLKIN (using DLLoutputs)	<i>CLKIN_FREQ_DLL_HF_Max</i>		A9, A10, A11		360.0 0	MHz
CLKIN (using CLKFXoutputs)	<i>CLKIN_FREQ_FX_HF_Min</i>		A9, A10, A11	50.00		MHz
CLKIN (using CLKFXoutputs)	<i>CLKIN_FREQ_FX_HF_Max</i>		A9, A10, A11		270.0 0	MHz

Test	Symbol	Conditions Limits 1.425V≤V _{CCINT} ≤1.575V, 3.0V≤V _{CCO} ≤3.6V, 3.0V≤V _{CCAUX} ≤3.6V, -55℃≤T _A ≤125℃	Group A Subgroups	Limits		units
				Min	Max	
TMS and TDI Setup times before TCK	T_{TAPTK}		A9, A10, A11	5.5		ns
TMS and TDI Hold times after TCK	T_{TCKTAP}		A9, A10, A11	0		ns
Output delay from clock TCK to output TDO	T_{TCKTDO}		A9, A10, A11		10	ns
Maximum TCK clock frequency	F_{TCK}		A9, A10, A11		33	MHz
LVTTL Global Clock Input to Output Delay using Output Flipflop, 12 mA, Fast Slew Rate, with DCM. Global Clock and OFF with DCM	$T_{ICKOFDCM}$		A9, A10, A11		2.88	ns
LVTTL Global Clock Input to Output Delay using Output Flipflop, 12 mA, Fast Slew Rate, without DLL. Global Clock and OFF without DCM	T_{ICKOF}		A9, A10, A11		6.62	ns

Test	Symbol	Conditions Limits $1.425V \leq V_{CCINT} \leq 1.575V$, $3.0V \leq V_{CCO} \leq 3.6V$, $3.0V \leq V_{CCAUX} \leq 3.6V$, $-55^{\circ}C \leq T_A \leq 125^{\circ}C$	Group A Subgroups	Limits		units
				Min	Max	
Input Setup and Hold Time Relative to Global Clock Input Signal for LVTTL Standard. No Delay Global Clock and IFF with DCM	T_{PSDCM} / T_{PHDCM}		A9, A10, A11		1.96/ -0.76	ns
Input Setup and Hold Time Relative to Global Clock Input Signal for LVTTL Standard. Full Delay Global Clock and IFF without DCM	T_{PSFD} / T_{PHFD}		A9, A10, A11		2.21/ 0.0	ns

Appendix II Application Notes

- Master CCLK Frequency

In Master Serial configuration mode, the CCLK frequency driven by BQR2V6000 is correlated to the OSCFSEL-Specified Master CCLK Frequencies set by the ISE design suit. The actual Master CCLK Frequency is much smaller than the setting value. Because of the structures of the internal oscillators, master CCLK frequency is accurate to $\pm 45\%$. If the configuration time matters for designer, the master CCLK Frequency deviation should be considered.

- CS_B&RDWR_B

Even the configuration mode is not SelectMAP, Chip Select (CS_B) signal, and a Write signal (RDWR_B) should be kept in a stable state. The logic level changing in those two pins may cause a failure during configuration.

- Develop tools

Xilinx ISE10.1 and synthesis tool XST are recommended. Third-party synthesis tools may compress the utility of logic resources, according to XST report the actual resources usage could exceed 100%, which should be avoided.

- PROM program

XCF series、XC18 series and XQR17 series PROMs are supported. In-System Programmable PROMs such as XCF series and XC18 series can be programmed individually, or two or more can be chained together and programmed in-system via the standard 4-pin JTAG protocol. When programming, JTAG signals are vulnerable, a PCB design should consider the JTAG signal integrity. If the programming process is failed, please check the JTAG connections and make sure the cable and connections are not disturbed by any other signals.

Appendix III BitGen and PROMGen Switches and Options

Using BitGen

BitGen produces a bitstream for device configuration. After the design has been completely routed, it is necessary to configure the device so that it can execute the desired function. The bitstream necessary to configure the device is generated with BitGen. BitGen takes a fully routed NCD (Circuit Description) file as its input and produces a configuration bitstream—a binary file with a .bit extension. The BIT file contains all of the configuration information from the NCD file defining the internal logic and interconnections of the FPGA, plus device-specific information from other files associated with the target device. The binary data in the BIT file can then be downloaded into the FPGA memory cells, or it can be used to create a PROM file (see Figure III-1).

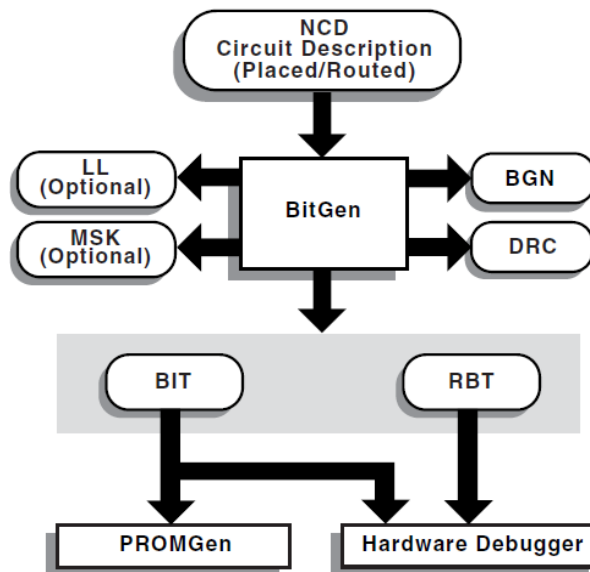

Figure III-1 BitGen

BitGen Syntax

The following syntax creates a bitstream from your NCD file.

bitgen [options] *infile* [.ncd] [*outfile*] [*pcf_file*]

options is one or more of the options listed in the "BitGen Options". *Infile* is the name of the NCD design for which you want to create the bitstream. You can specify only one design file, and it must be the first file specified on the command line. You do not have to use an extension. If you do not, **.ncd** is assumed. If you do use an extension, it must be **.ncd**. *Outfile* is the name of the output file. If you do not specify

an output file name, BitGen creates one in the same directory as the input file. If you specify `-l` on the command line, the extension is `.ll` (see `-l` command line option). If you specify `-m` (see `-m` command line option), the extension is `.msk`. If you specify `-b`, the extension is `.rbt`. Otherwise the extension is `.bit`. If you do not specify an extension, BitGen appends one according to the aforementioned rules. If you do include an extension, it must also conform to the rules. *Pcf_file* is the name of a physical constraints (PCF) file. BitGen uses this file to determine which nets in the design are critical for tiedown. BitGen automatically reads the `.pcf` file by default. If the physical constraints file is the second file specified on the command line, it must have a `.pcf` extension. If it is the third file specified, the extension is optional; `.pcf` is assumed. If a `.pcf` file name is specified, it must exist, otherwise the input design name with a `.pcf` extension is read if that file exists. A report file containing all BitGen's output is automatically created under the same directory as the output file. The report file has the same root name as the output file with a `.bgn` extension.

BitGen Files

This section describes input files that BitGen requires and output files that BitGen generates.

Input Files

Input to BitGen consists of the following files.

- NCD file—a physical description of the design mapped, placed and routed in the target device. The NCD file must be fully routed.
- PCF—an optional user-modifiable ASCII Physical Constraints File. If you specify a PCF file on the BitGen command line, BitGen uses this file to determine which nets in the design are critical for tiedown (not used for Virtex families).

Output Files

Output from BitGen consists of the following files.

- BIT file—a binary file with a `.bit` extension. The BIT file contains all of the configuration information from the NCD file defining the internal logic and interconnections of the FPGA, plus device-specific information from other files associated with the target device. The binary data in the BIT file can then be downloaded into the FPGA memory cells, or it can be used to create a PROM file.
- RBT file—an optional “rawbits” file with an `.rbt` extension. The rawbits file is ASCII ones and zeros representing the data in the bitstream file. If you enter a `-b` option on the BitGen command line, an RBT file is produced in addition to the binary BIT file.

- LL file—an optional ASCII logic allocation file with a .ll extension. The logic allocation file indicates the bitstream position of latches, flip-flops, and IOB inputs and outputs. A .ll file is produced if you enter a -l option on the BitGen command line.

- MSK file—an optional mask file with an .msk extension. This file is used to compare relevant bit locations for executing a readback of configuration data contained in an operating FPGA. A MSK file is produced if you enter a -m option on the BitGen command line.

- BGN file—a report file containing information about the BitGen run.

- DRC file—a Design Rule Check (DRC) file for the design. A DRC runs and the DRC file is produced unless you enter a -d option on the BitGen command line.

BitGen Options

Following is a description of command line options and how they affect BitGen behavior.

-b (Create Rawbits File)

Create a “rawbits” (*file_name.rbt*) file. The rawbits file consists of ASCII ones and zeros representing the data in the bitstream file. If you are using a microprocessor to configure a single FPGA, you can include the rawbits file in the source code as a text file to represent the configuration data. The sequence of characters in the rawbits file is the same as the sequence of bits written into the FPGA.

-d (Do Not Run DRC)

Do not run DRC (Design Rule Check). Without the -d option, BitGen runs a DRC and saves the DRC results in two output files: the BitGen report file (*file_name.bgn*) and the DRC file (*file_name.drc*). If you enter the -d option, no DRC information appears in the report file and no DRC file is produced. Running DRC before a bitstream is produced detects any errors that could cause the FPGA to malfunction. If DRC does not detect any errors, BitGen produces a bitstream file (unless you use the -j option).

-f (Execute Commands File)

-f *command_file*

The -f option executes the command line arguments in the specified *command_file*.

-g (Set Configuration)

-g option:setting

The -g option specifies the startup timing and other bitstream options for FPGAs. The settings for the -g option depend on the design’s architecture. These

options have the following syntax:

Binary

Creates a binary file with programming data only. Use this option to extract and view programming data. Any changes to the header will not affect the extraction process.

Settings: No, Yes

Default: No

Cclk Pin

Adds an internal pull-up to the Cclk pin. The Pullnone setting disables the pullup.

Settings: Pullnone, Pullup

Default: Pullup

Compress

This option uses the multiple frame write feature in the bitstream to reduce the size of the bitstream, not just the .bit file. Using the Compress option does not guarantee that the size of the bitstream will shrink.

Config Rate

An internal oscillator to generate the configuration clock, CCLK, when configuring in a master mode. Use the configuration rate option to select the rate for this clock.

Settings: 4, 5, 7, 8, 9, 10, 13, 15, 20, 26, 30, 34, 41, 45, 51, 55, 60

Default: 4

DCM Shutdown

When DCM Shutdown is enabled, the DCM (Digital Clock Manager) resets if the SHUTDOWN and AGHIGH commands are loaded into the configuration logic.

Settings: Disable, Enable

Default: Disable

Debug Bitstream

If the device does not configure correctly, you can debug the bitstream using the Debug Bitstream option. A debug bitstream is significantly larger than a standard bitstream. The values allowed for the Debug Bitstream option are No and Yes.

Note: You should use this option only if your device is configured to use slave or master serial mode.

Values: No, Yes

In addition to a standard bitstream, a debug bitstream offers the following features:

- Writes 32 0s to the LOUT register after the synchronization word
- Loads each frame individually
- Performs a cyclical redundancy check (CRC) after each frame
- Writes the frame address to the LOUT register after each frame

Disable Bandgap

Disables bandgap generator for DCMs to save power.

Settings: No, Yes

Default: No

DONE_cycle

Selects the Startup phase that activates the FPGA Done signal. Done is delayed when DonePipe=Yes.

Settings: 1, 2, 3, 4, 5, 6

Default: 4

Done Pin

Adds an internal pull-up to the DONE Pin pin. The Pullnone setting disables the pullup. Use this option only if you are planning to connect an external pull-up resistor to this pin. The internal pull-up resistor is automatically connected if you do not use this option.

Settings: Pullup, Pullnone

Default: Pullup

Done Pipe

This option is intended for use with FPGAs being set up in a high-speed daisy chain configuration. When set to Yes, the FPGA waits on the CFG_DONE (DONE) pin to go High and then waits for the first clock edge before moving to the Done state.

Settings: No, Yes

Default: No

Drive Done

This option actively drives the DONE Pin high as opposed to using a pullup.

Settings: No, Yes

Default: No

Encrypt

Encrypts the bitstream.

Settings: No, Yes

Default: No

GTS_cycle

Selects the Startup phase that releases the internal 3-state control to the I/O buffers. The Done setting releases GTS when the DoneIn signal is High. DoneIn is either the value of the Done pin or a delayed version if DonePipe=Yes

Settings: Done, 1, 2, 3, 4, 5, 6, Keep

Default: 5

GWE_cycle

Selects the Startup phase that asserts the internal write enable to flip-flops, LUT RAMs, and shift registers. It also enables the BRAMs. Before the Startup phase both BRAM writing and reading are disabled. The Done setting asserts GWE when the DoneIn signal is High. DoneIn is either the value of the Done pin or a delayed version if DonePipe=Yes. The Keep setting is used to keep the current value of the GWE signal

Settings: Done, 1, 2, 3, 4, 5, 6, Keep

Default: 6

Key0, Key1, Key2, Key3, Key4, Key5

Sets Key_x for bitstream encryption. The Pick option causes BitGen to select a random number for the value.

Settings: Pick, <hex_string>

Default: Pick

Key File

Specifies the name of the input encryption file.

Settings: <string>

Keyseq0, Keyseq1, Keyseq2, Keyseq3, Keyseq4, Keyseq5

Sets the key sequence for key_x. The settings are equal to the following:

- S = single
- F = first
- M = middle
- L = last

Settings: S, F, M, L

Default: S

LCK_cycle

Selects the Startup phase to wait until DLLs/DCMs lock. If NoWait is selected, the Startup sequence does not wait for DLLs/DCMs.

Settings: 0, 1, 2, 3, 4, 5, 6, NoWait

Default: NoWait

M0 Pin

The M0 pin is used to determine the configuration mode. Adds an internal pull-up, pulldown or neither to the M0 pin. The following settings are available. The default is PullUp. Select Pullnone to disable both the pull-up resistor and pull-down resistor on the M0 pin.

Settings: Pullup, Pulldown, Pullnone

Default: Pullup

M1 Pin

The M1 pin is used to determine the configuration mode. Adds an internal pull-up, pulldown or neither to the M1 pin. The following settings are available. The default is PullUp. Select Pullnone to disable both the pull-up resistor and pull-down resistor on the M1 pin.

Settings: Pullup, Pulldown, Pullnone

Default: Pullup

M2 Pin

The M2 pin is used to determine the configuration mode. Adds an internal pull-up, pulldown or neither to the M2 pin. The default is PullUp. Select Pullnone to disable both the pull-up resistor and pull-down resistor on the M2 pin.

Settings: Pullup, Pulldown, Pullnone

Default: Pullup

Match_cycle

Specifies a stall in this Startup cycle until DCI (Digitally Controlled Impedance) match signals are asserted.

Settings: NoWait, 0, 1, 2, 3, 4, 5, 6

Default: NoWait

Persist

This option is needed for Readback and Partial Reconfiguration using the SelectMAP configuration pins. If Persist is set to Yes, the pins used for SelectMAP mode are prohibited for use as user IO. Refer to the data sheet for a description of SelectMAP mode and the associated pins.

Settings: No, Yes

Default: No

ProgPin

Adds an internal pull-up to the ProgPin pin. The Pullnone setting disables the pull-up. The pull-up affects the pin after configuration.

Settings: Pullup, Pullnone

Default: Pullnone

ReadBack

This option allows you to perform Readback by the creating the necessary bitstream. When specifying the -g Readback option, the .rba, .rbb, .rbd, and .msd file are created.

Security

Selecting Level1 disables Readback. Selecting Level2 disables Readback and Partial Reconfiguration.

Settings: None, Level1, Level2

Default: None

StartCBC

Sets the starting CBC (Cipher Block Chaining) value. The pick option causes BitGen to select a random number for the value.

Settings: Pick, <hex_string>

Default: Pick

StartKey

Sets the starting key number.

Settings: 0, 3

Default: 0

StartupClk

The startup sequence following the configuration of a device can be synchronized to either Cclk, a User Clock, or the JTAG Clock. The default is Cclk.

Cclk

Enter Cclk to synchronize to an internal clock provided in the FPGA device.

JTAG Clock

Enter JtagClk to synchronize to the clock provided by JTAG. This clock sequences the TAP controller which provides the control logic for JTAG.

UserClk

Enter UserClk to synchronize to a user-defined signal connected to the CLK pin of the STARTUP symbol.

Settings: Cclk (pin—see Note), UserClk (user-supplied), JtagCLK

Default: Cclk

NOTE: In modes where Cclk is an output, the pin is driven by an internal oscillator.

Tck Pin

Adds a pull-up, a pull-down or neither to the TCK pin, the JTAG test clock. Selecting one setting enables it and disables the others. The Pullnone setting indicates there is no connection to either the pull-up or the pull-down.

Settings: Pullup, Pulldown, Pullnone

Default: Pullup

Tdi Pin

Adds a pull-up, a pull-down, or neither to the TDI pin, the serial data input to all JTAG instructions and JTAG registers. Selecting one setting enables it and disables the others. The Pullnone setting indicates there is no connection to either the pull-up or the pulldown.

Settings: Pullup, Pulldown, Pullnone

Default: Pullup

Tdo Pin

Adds a pull-up, a pull-down, or neither to the TdoPin pin, the serial data output for all JTAG instruction and data registers. Selecting one setting enables it and disables the others. The Pullnone setting indicates there is no connection to either the pull-up or the pulldown.

Settings: Pullup, Pulldown, Pullnone

Default: Pullup

Tms Pin

This option selects an internal pullup or pulldown on the TMS (JTAG Mode Select) pin.

Settings: Pullnone, Pullup, Pulldown

Default: Pullup

Unused Pin

Adds a pull-up, a pull-down, or neither to the Unused Pin, the serial data output for all JTAG instruction and data registers. Selecting one setting enables it and disables the others. The Pullnone setting indicates there is no connection to either the pull-up or the pulldown. The following settings are available. The default is PullDown.

Settings: Pullup, Pulldown, Pullnone

Default: Pulldown

User ID

You can enter up to an 8-digit hexadecimal code in the User ID register. You can use the register to identify implementation revisions.

-h or -help (Command Usage)

-h architecture

Displays a usage message for BitGen. The usage message displays all available options for BitGen operating on the specified *architecture*.

-j (No BIT File)

Do not create a bitstream file (.bit file). This option is generally used when you want to generate a report without producing a bitstream. For example, if you wanted to run DRC without producing a bitstream file, you would use the -j option.

Note: The .msk or .rbit files might still be created.

-l (Create a Logic Allocation File)

This option creates an ASCII logic allocation file (*design.ll*) for the selected design. The logic allocation file indicates the bitstream position of latches, flip-flops, and IOB inputs and outputs. In some applications, you may want to observe the contents of the FPGA internal registers at different times. The file created by the -l option helps you identify which bits in the current bitstream represent outputs of flip-flops and latches. Bits are referenced by frame and bit number within the frame. The Hardware Debugger uses the **design.ll** file to locate signal values inside a readback bitstream.

-m (Generate a Mask File)

Creates a mask file. This file is used to compare relevant bit locations for executing a readback of configuration data contained in an operating FPGA.

-w (Overwrite Existing Output File)

Enables you to overwrite an existing BIT, LL, MSK, or RBT output file.

Using PROMGen

PROMGen formats a BitGen-generated configuration bitstream (BIT) file into a PROM format file (Figure III-2).

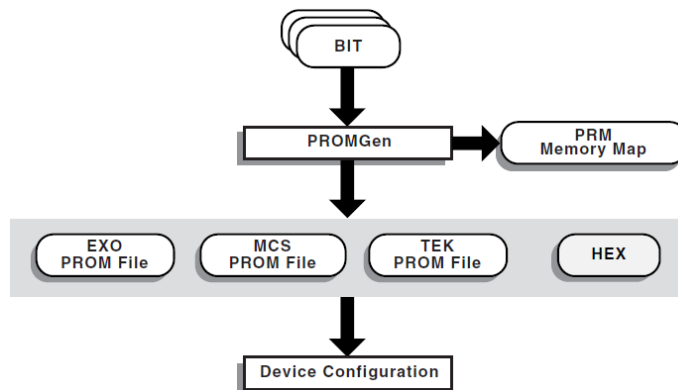

Figure III-2 PROMGen

The PROM file contains configuration data for the FPGA device. PROMGen

converts a BIT file into one of three PROM formats: MCS-86 (Intel), EXORMAX (Motorola), or TEKHEX (Tektronix). It can also generate a Hex file format. You can also use PROMGen to concatenate bitstream files to daisy-chain FPGAs.

Note: If the destination PROM is one of the Xilinx Serial PROMs, you are using a Xilinx PROM Programmer, and the FPGAs are not being daisy-chained, it is not necessary to make a PROM file.

PROMGen Syntax

Use the following syntax to start PROMGen from the operating system prompt:

promgen [*options*]

Options can be any number of the options listed in "PROMGen Options". Separate multiple options with spaces.

PROMGen Files

This section describes the PROMGen input and output files.

Input Files

The input to PROMGEN consists of BIT files— one or more bitstream files. BIT files contain configuration data for an FPGA design.

Output Files

Output from PROMGEN consists of the following files.

- PROM files—The file or files containing the PROM configuration information. Depending on the PROM file format used by the PROM programmer, you can output a TEK, MCS, or EXO file. If you are using a microprocessor to configure your devices, you can output a HEX file, containing a hexadecimal representation of the bitstream.

- PRM file—The PRM file is a PROM image file. It contains a memory map of the output PROM file. The file has a **.prm** extension.

Bit Swapping in PROM Files

PROMGen produces a PROM file in which the bits within a byte are swapped compared to the bits in the input BIT file. Bit swapping (also called “bit mirroring”) reverses the bits within each byte, as shown in Figure III-3.

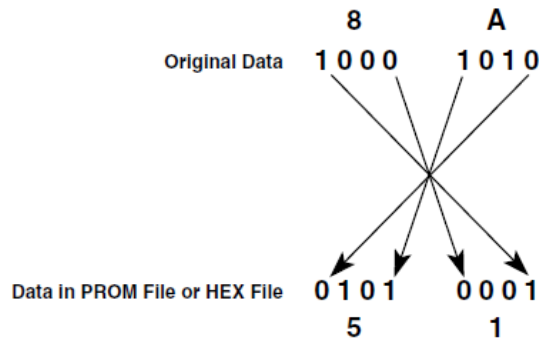

Figure III-3 Bit Swapping

In a bitstream contained in a BIT file, the Least Significant Bit (LSB) is always on the left side of a byte. But when a PROM programmer or a microprocessor reads a data byte, it identifies the LSB on the right side of the byte. In order for the PROM programmer or microprocessor to read the bitstream correctly, the bits in each byte must first be swapped so they are read in the correct order. In this release of the Xilinx Development System, the bits are swapped for all of the PROM formats: MCS, EXO, and TEK. For a HEX file output, bit swapping is on by default, but it can be turned off by entering a `-b PROMGen` option that is available only for HEX file format.

PROMGen Options

This section describes the options that are available for the PROMGen command.

`-b` (Disable Bit Swapping—HEX Format Only)

This option only applies if the `-p` option specifies a HEX file for the output of PROMGen. By default (no `-b` option), bits in the HEX file are swapped compared to bits in the input BIT files. If you enter a `-b` option, the bits are not swapped. Bit swapping is described in "Bit Swapping in PROM Files".

`-c` (Checksum)

promgen -c

The `-c` option generates a checksum value appearing in the `.prm` file. This value should match the checksum in the prom programmer. Use this option to verify that correct data was programmed into the prom.

`-d` (Load Downward)

promgen -d hexaddress0 filename filename...

This option loads one or more BIT files from the starting address in a downward direction. Specifying several files after this option causes the files to be concatenated in a daisy chain. You can specify multiple `-d` options to load files at different addresses. You must specify this option immediately before the input bitstream file. The multiple file syntax is as follows:

promgen -d *hexaddress0 filename filename...*

The multiple **-d** options syntax is as follows:

promgen -d *hexaddress1 filename -d hexaddress2 filename...*

-f (Execute Commands File)

-f *command_file*

The **-f** option executes the command line arguments in the specified *command_file*.

-help (Command Help)

This option displays help that describes the PROMGen options.

-n (Add BIT Files)

-n *file1[.bit] file2[.bit]...*

This option loads one or more BIT files up or down from the next available address following the previous load. The first **-n** option *must* follow a **-u** or **-d** option because **-n** does not establish a direction. Files specified with this option are not daisy-chained to previous files. Files are loaded in the direction established by the nearest prior **-u**, **-d**, or **-n** option. The following syntax shows how to specify multiple files. When you specify multiple files, PROMGen daisy-chains the files.

promgen -d *hexaddress file0 -n file1 file2...*

The following syntax when using multiple **-n** options prevents the files from being daisy-chained:

promgen -d *hexaddress file0 -n file1 -n file2...*

-o (Output File Name)

-o *file1[.ext] file2[.ext]...*

This option specifies the output file name of a PROM if it is different from the default. If you do not specify an output file name, the PROM file has the same name as the first BIT file loaded. *ext* is the extension for the applicable PROM format. Multiple file names may be specified to split the information into multiple files. If only one name is supplied for split PROM files (by you or by default), the output PROM files are named *file_#.ext*, where *file* is the base name, # is 0, 1, etc., and *ext* is the extension for the applicable PROM format.

promgen -d *hexaddress file0 -o filename*

-p (PROM Format)

-p { **mcs** | **exo** | **tek** | **hex** }

This option sets the PROM format to one of the following: MCS (Intel MCS86), EXO (Motorola EXORMAX), TEK (Tektronix TEKHEX). The option may also

produce a HEX file, which is a hexadecimal representation of the configuration bitstream used for microprocessor downloads. If specified, the -p option must precede any -u, -d, or -n options. The default format is MCS.

-r (Load PROM File)

-r *promfile*

This option reads an existing PROM file as input instead of a BIT file. All of the PROMGen output options may be used, so the -r option can be used for splitting an existing PROM file into multiple PROM files or for converting an existing PROM file to another format.

-s (PROM Size)

-s *promsize1 promsize2...*

This option sets the PROM size in kilobytes. The PROM size must be a power of 2. The default value is 64 kilobytes. The -s option must precede any -u, -d, or -n options. Multiple *promsize* entries for the -s option indicates the PROM will be split into multiple PROM files.

Note: PROMGen PROM sizes are specified in bytes. The Programmable Logic Data Book specifies PROM sizes in bits for Xilinx serial PROMs (see -x option).

-u (Load Upward)

-u *hexaddress0 filename1 filename2...*

This option loads one or more BIT files from the starting address in an upward direction. When you specify several files after this option, PROMGen concatenates the files in a daisy chain. You can load files at different addresses by specifying multiple -u options. This option must be specified immediately before the input bitstream file.

-x (Specify Xilinx PROM)

-x *xilinx_prom1 xilinx_prom2...*

The -x option specifies one or more Xilinx serial PROMs for which the PROM files are targeted. Use this option instead of the -s option if you know the Xilinx PROMs to use. Multiple *xilinx_prom* entries for the -x option indicates the PROM will be split into multiple PROM files.

Examples

To load the file test.bit up from address 0x0000 in MCS format, enter the following information at the command line.

promgen -u 0 test

To daisy-chain the files test1.bit and test2.bit up from address 0x0000 and the

files test3.bit and test4.bit from address 0x4000 while using a 32K PROM and the Motorola EXORmax format, enter the following information at the command line.

promgen -s 32 -p exo -u 00 test1 test2 -u 4000 test3 test4

To load the file test.bit into the PROM programmer in a downward direction starting at address 0x400, using a Xilinx XC1718D PROM, enter the following information at the command line.

promgen -x xc1718d -d 0x400 test

To specify a PROM file name that is different from the default file name enter the following information at the command line.

promgen options filename -o newfilename

Service and Support:

Address: No.2 Siyingmen N. Road. Donggaodi. Fengtai District. Beijing. China.

Department: Department of international cooperation

telephone: 010-67968115-8548

Fax: 010-68757706

Zip code: 100076