

### 描述 / Descriptions

TO-92 塑封封装精密可调基准电源。

Precision adjustable shunt regulator in a TO-92 Plastic Package.

### 特征 / Features

精确参照电压 2.500V;允许电压误差为 0.4%,0.8%;阴极电流能力为 1.0mA ~ 100mA;快速导通;可调节输出电压为  $V_O = V_{ref} \sim 37V$ ;阴极工作电流低(典型值:400 $\mu$ A);动态输出阻抗低(典型值:0.15 $\Omega$ )。

Precise reference voltage to 2.500V;guaranteed 0.4%,0.8% reference voltage Tolerance; sink current capability,1.0mA~100mA;quick turn-on; adjustable Output voltage,  $V_O = V_{ref} \sim 37V$ ;low operational cathode current,400 $\mu$ A typical; 0.15 $\Omega$  typical output impedance.

### 用途 / Applications

用于线性调整器,可调节电源和开关电源。

Linear regulators, adjustable power supply, switching power supply.

### 内部等效电路 / Equivalent Circuit

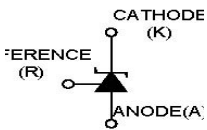

### 引脚排列 / Pinning



PIN 1 : K

PIN 2 : A

PIN 3 : R

### 印章代码 / Marking

见印章说明。 See Marking Instructions

**极限参数 / Absolute Maximum Ratings(Ta=25°C)**

参数 Parameter	符号 Symbol	数值 Rating	单位 Unit
Cathode to Anode Voltage	$V_{KA}$	37	V
Cathode Current Range, Continuous	$I_K$	-100~+150	mA
Reference Input Current Range, Continuous	$I_{REF}$	0.05~+10	mA
Power Dissipation	$P_D$	770	mW
Operating Ambient Temperature	$T_{amb}$	-40~125	°C
Junction Temperature	$T_j$	160	°C
Storage Temperature Range	$T_{stg}$	-65~150	°C

**电性能参数 / Electrical Characteristics(Ta=25°C)**

参数 Parameter	符号 Symbol	测试条件 Test Conditions	最小值 Min	典型值 Typ	最大值 Max	单位 Unit
Reference Input voltage	$V_{REF}$	$V_{KA}=V_{REF}$ $I_K=10mA(A=0.4\%)$	2.490	2.500	2.510	V
		$V_{KA}=V_{REF}$ $I_K=10mA(B=0.8\%)$	2.480	2.500	2.520	V
Deviation of Reference Input Voltage Over-Temperature	$\Delta V_{REF}/T$	$V_{KA}=V_{REF}$ $I_K=10mA$ $T_A=-25\sim 85^\circ C$		4.5	17	mV
Ratio of Change in Reference Input Voltage to the Change in Cathode Voltage	$\Delta V_{REF}/\Delta V_{KA}$	$I_K=10mA$ $\Delta V_{KA}=10V$ to $V_{REF}$		-1	-2.7	mV/V
		$I_K=10mA$ $\Delta V_{KA}=36V$ to $10V$		-0.45	-2.0	mV/V
Reference Input current	$I_{REF}$	$I_K=10mA$ $R_1=10K\Omega$ $R_2=open$		1.0	4.0	$\mu A$
Deviation of Reference Input Current Over Full Temperature Range	$\Delta I_{REF}/T$	$I_K=10mA$ $R_1=10K\Omega$ , $R_2=open$ $T_A=-40\sim 125^\circ C$		0.4	1.2	$\mu A$
Minimum Cathode Current for Regulation	$I_{K(min)}$	$V_{KA}=V_{REF}$		0.4	1.0	mA
Off-state cathode current	$I_{K(off)}$	$V_{KA}=36V$ $V_{REF}=0V$		0.05	1.0	$\mu A$
Dynamic impedance	$ Z_{KA} $	$V_{KA}=V_{REF}$ $f\leq 1.0KHz$ $I_K=1mA$ to $100mA$		0.15	0.5	$\Omega$

**测试电路图&典型应用图 Test circuits&Typical Application**

**BLOCK DIAGRAM:**

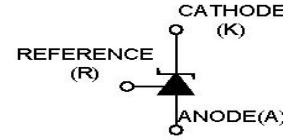
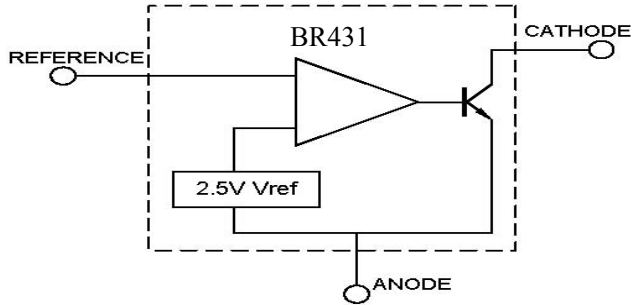

**TEST CIRCUITS:**

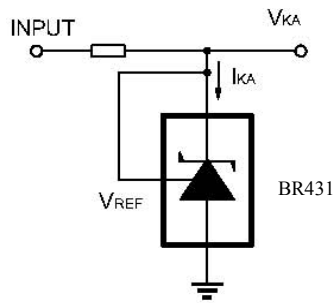

Test Circuit For  $V_{KA} = V_{REF}$

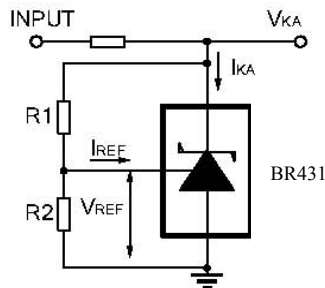

Test Circuit for  $V_{KA} \geq V_{REF}$   
 $V_{KA} = V_{REF} \cdot (1 + R1/R2) + I_{REF} \cdot R1$

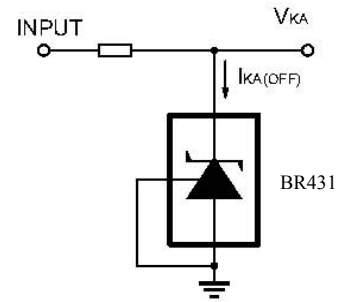

Test Circuit For  $I_{KA(OFF)}$

**TYPICAL APPLICATION:**

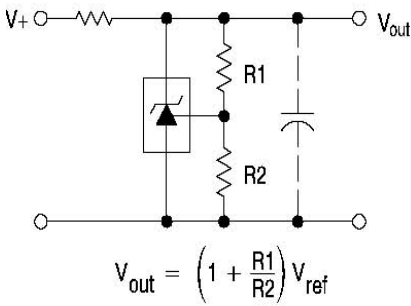

Shutdown Regulator  
 $V_{out} = \left(1 + \frac{R1}{R2}\right) V_{ref}$

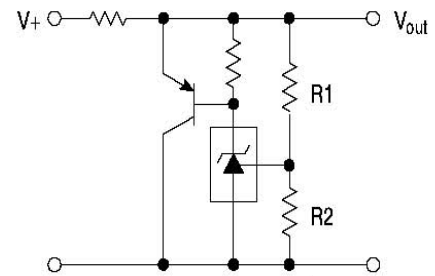

Higher-current Shunt  
 $V_{out} = \left(1 + \frac{R1}{R2}\right) V_{ref}$

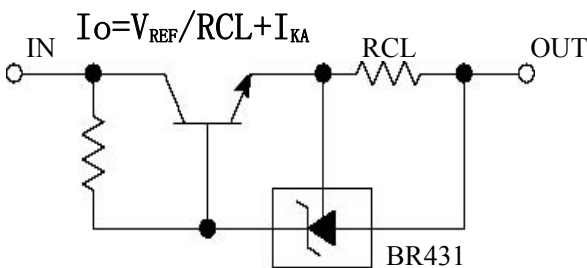

Constant Current Source  
 $I_o = V_{REF}/R_{CL} + I_{KA}$

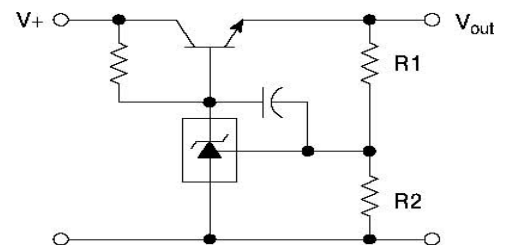

Series Pass Regulator  
 $V_{out} = \left(1 + \frac{R1}{R2}\right) V_{ref}$   
 $V_{out\ min} = V_{ref} + V_{be}$

电参数曲线图 / Electrical Characteristic Curve

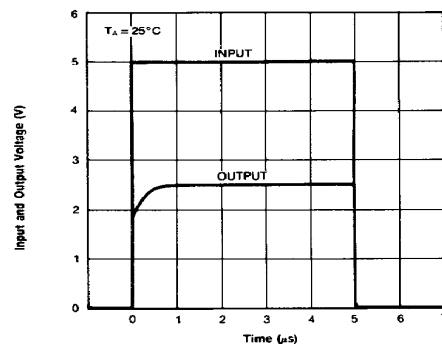
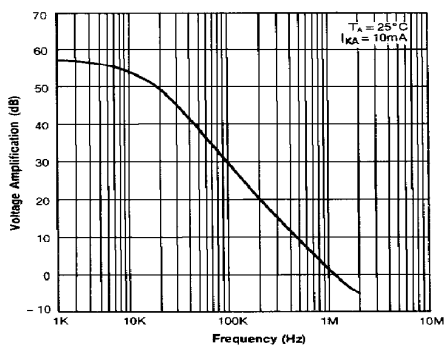
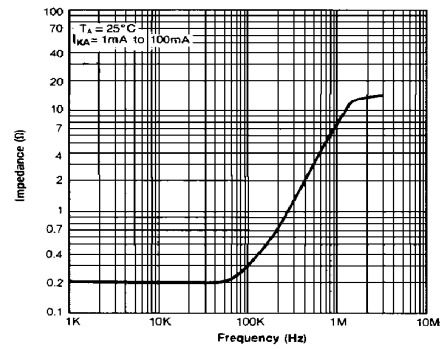
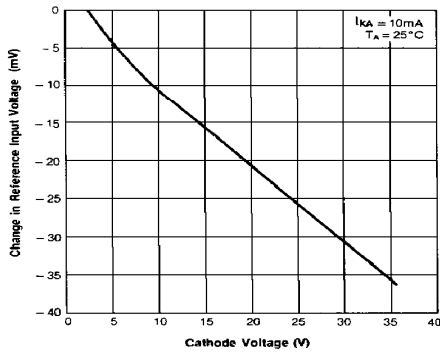
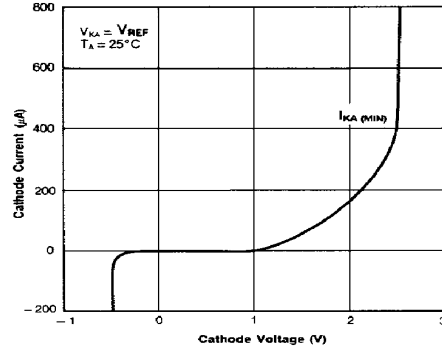
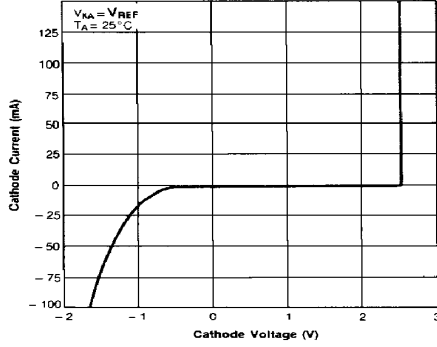

外形尺寸图 / Package Dimensions

TO-92

Unit: mm

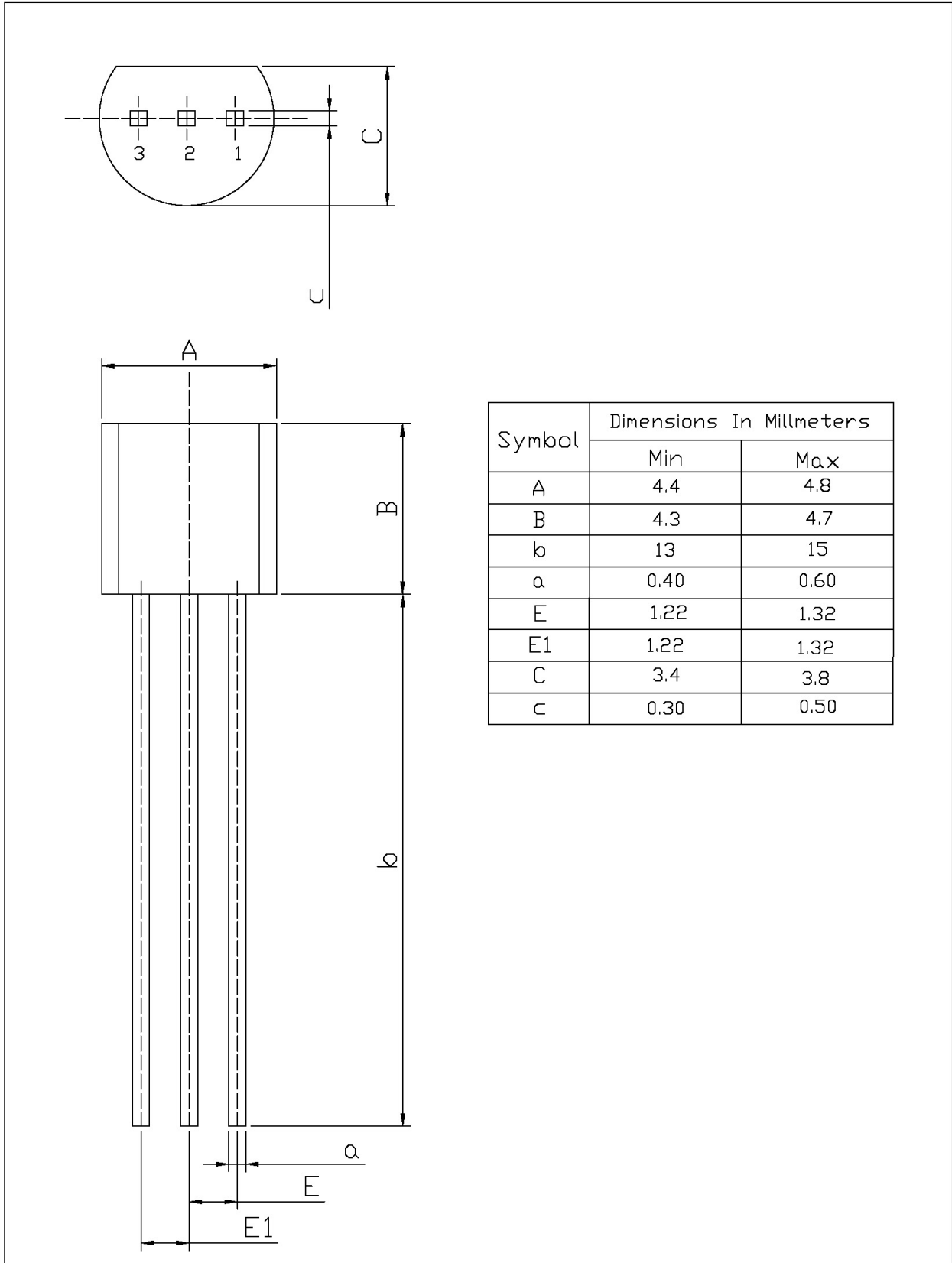

印章说明 / Marking Instructions

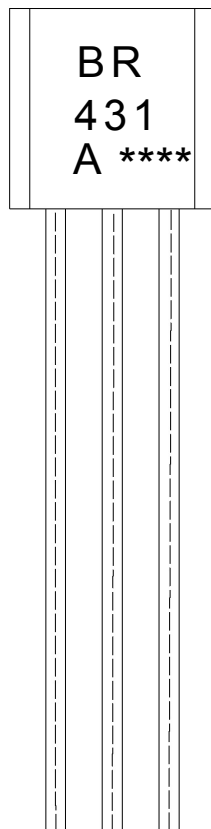

说明：

BR： 为公司代码

431： 为型号代码

A： 为  $h_{FE}$  分档代码

\*\*\*\*： 为生产批号代码，随生产批号变化。

Note:

BR: Company Code.

431: Product Type Code.

A:  $h_{FE}$  Classifications Symbol

\*\*\*\*: Lot No. Code, code change with Lot No.

**波峰焊温度曲线图(无铅) / Temperature Profile for Dip Soldering(Pb-Free)**

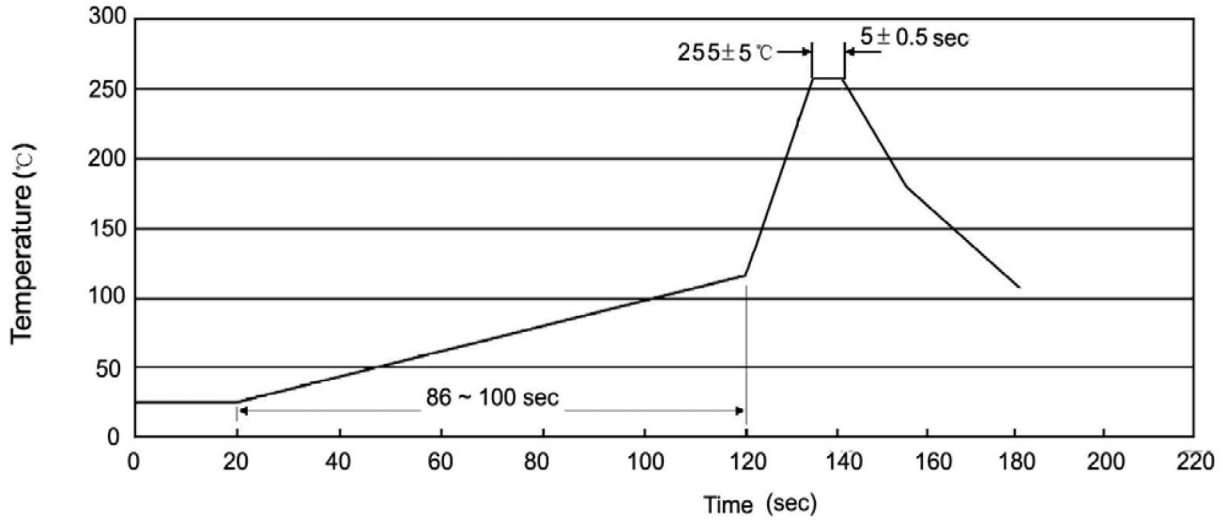

说明：

- 1、预热温度 25~150°C，时间 60~90sec;
- 2、峰值温度 255±5°C，时间持续为 5±0.5sec;
- 3、焊接制程冷却速度为 2~10°C/sec.

Note:

- 1.Preheating:25~150°C, Time:60~90sec.
- 2.Peak Temp.:255±5°C, Duration:5±0.5sec.
3. Cooling Speed: 2~10°C/sec.

**耐焊接热试验条件 / Resistance to Soldering Heat Test Conditions**

温度：270±5°C      时间：10±1 sec.      Temp:270±5°C      Time:10±1 sec

**包装规格 / Packaging SPEC.**

散件包装 / BULK

Package Type 封装形式	Units 包装数量					Dimension 包装尺寸 (unit: mm3)		
	Units/Bag 只/袋	Bags/Inner Box 袋/盒	Units/Inner Box 只/盒	Inner Boxes/Outer Box 盒/箱	Units/Outer Box 只/箱	Bag 袋	Inner Box 盒	Outer Box 箱
TO-92	1,000	10	10,000	5	50,000	135×190	237×172×102	560×245×195
	1,000	10	10,000	10	100,000	135×190	237×172×102	560×245×375

编带包装 / AMMO

Package Type 封装形式	Units 包装数量					Dimension 包装尺寸 (unit: mm3)	
	Units/tape 只/纸带	Tape/Inner Box 纸带/盒	Rows/Inner Box 纸带层/盒	Inner Boxes/Outer Box 盒/箱	Units/Outer Box 只/箱	Inner Box 盒	Outer Box 箱
TO-92	3,000	1	120	10	30,000	328×230×42	小箱 480×346×235, 大箱 547×407×268

**使用说明 / Notices**