



BR550D15(AU)

Product Specification

**SPECIFICATION
FOR
APPROVAL**

Title	55.0" WUXGA TFT LCD
-------	---------------------

BUYER	
MODEL	BR550D15
SUFFIX	AU



BR550D15(AU)

Product Specification

1. General Description

The BR550D15 is a Color Active Matrix Liquid Crystal Display with an integral Light Emitting Diode (LED) backlight system. The matrix employs a-Si Thin Film Transistor as the active element.

It is a transmissive type display operating in the normally black mode. This TFT-LCD has a 54.64 inch diagonal measured active display area with WUXGA resolution(1080 vertical by 1920 horizontal pixel array) Each pixel is divided into Red, Green and Blue sub-pixels or dots which are arranged in vertical stripes.

Gray scale or the brightness of the sub-pixel color is determined with a 10-bit gray scale signal for each dot, thus, presenting a palette of more than 1.06Billion colors.

It is intended to support Public Display where high brightness, super wide viewing angle, high color gamut, high color depth and fast response time are important.

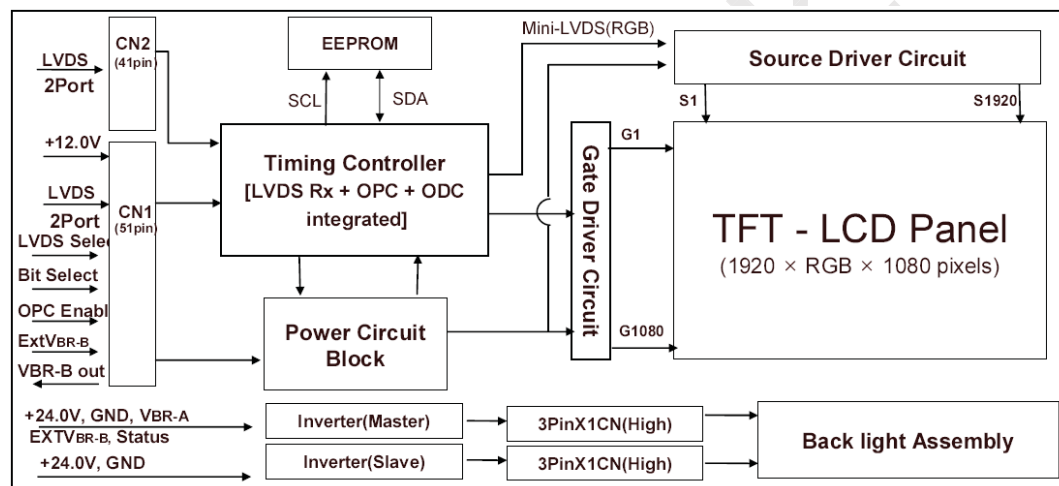

General Features

Active screen size	54.64 inch (1387.80mm) diagonal	
Outline Dimension	1286.0(H) x 745.0(V) x 60.0(D) mm(Typ.)	
Active Area	1209.6(H) x 680.4(V) mm	
Pixel Pitch	0.630 mm x 0.630 mm	
Pixel Format	1920 horiz. by 1080 vert. Pixels. RGB stripe arrangement	
Display Colors	10bit 1.06Billion colors	
Luminance, white	1500 cd/m ² (Typ. Center 1 point)	
Power Consumption	387.56 W	Watts(Typ.) (PDD=7.56W PBL=380W)
Weight	21Kg (Typ.)	
Display operating mode	Transmissive mode, normally black	
Surface treatments	Hard coating (3H), Anti-glare treatment of the front polarizer	



BR550D15(AU)

Product Specification

2. Absolute maximum ratings

The following are maximum values which, if exceeded, may cause faulty operation or damage to the unit.

Table 1. Absolute Maximum Ratings

Parameter	Symbol	Values		Units	Notes
		Min	Max		
Power Supply Input Voltage	V_{CC}	-0.3	+14.0	V_{dc}	At 25°C
Operating Temperature	T_{OP}	0	+50	°C	1
Storage Temperature	T_{ST}	-20	+60	°C	1
Operating Ambient Humidity	H_{OP}	10	+90	%RH	1
Storage Humidity	H_{ST}	10	+90	%RH	1

Note : 1. Temperature and relative humidity range are shown in the figure below. Wet bulb temperature should be 39 °C Max, and no condensation of water.

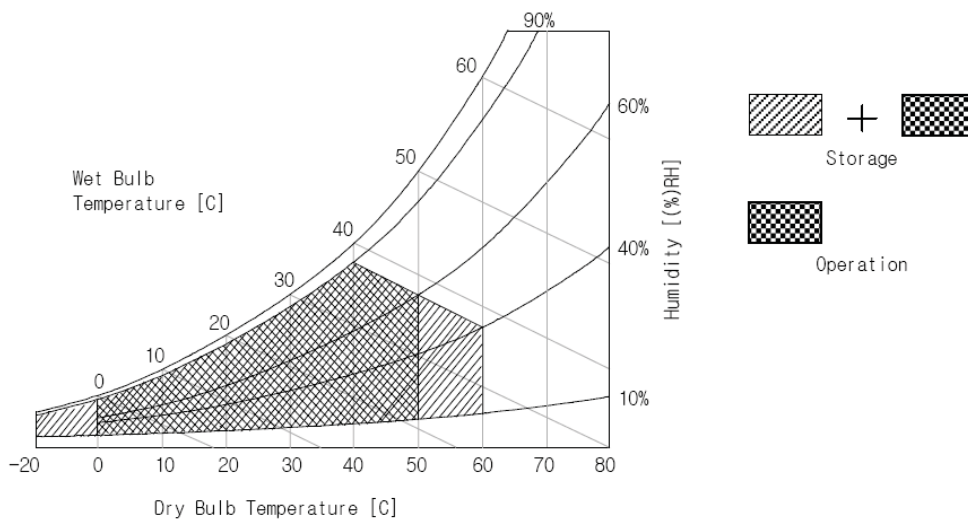

Figure 2. Temperature and relative humidity



BR550D15(AU)

Product Specification

3. Electrical specifications

3-1. Electrical characteristics

The BR550D15 requires two power inputs. One is employed to power the LCD electronics and to drive the TFT array and liquid crystal. Another which powers the LED Backlight .LED Driver is an internal unit to the LCD.

Table 2. Electrical Characteristics

Parameter	Symbol	Values			Units	Notes
		Min	Type	Max		
Power Supply Input Voltage	V _{CC}	10.8	12.0	13.2	V	
Permissive Power Input Ripple	V _{RF}	-	-	0.1	V	
Power Supply Input Current	I _{CC}	-	0.875	1.14	A	1
Power Consumption	P _C	-	7.56	10.8	Watts	
In Rush Current	I _{RUSH}	-	-	5	A	2
LED Power supply Voltage	V _{BL}	22.8	24	-	V	3
LED Power Supply current	I _{BL}	-	15.83	-	A	
LED BL Power Consumption	P _{BL}	-	380	-	Watts	4
Brightness Adjust	V _{BR-B}	10	-	100	%	On Duty
Linear Brightness Adjust	V _{BR-A}	0	-	3.3	V	
Life Time		50,000			Hrs	5

Note: Do not attach a conducting tape to lamp connecting wire. If the lamp wire attach to conducting tape TFT-LCD Module have a low luminance.

- 1.The specified current and power consumption are under the V_{CC}=12.0V, 25°C, f_v (frame frequency)=120Hz condition.
- 2.The duration of rush current is about 2ms. And V_{CC} rise time is 500us ± 20%.
- 3.Operating voltage is measured under 25°C.
- 4.The LED Backlight power consumption shown above include LED Diver Module under 25°C.
- 5.The life time is determined as the time at which brightness of lamp is 50% compared to that of initial value at the typical lamp current on condition of continuous operating at 25°C.



BR550D15(AU)

Product Specification

3-2. Interface Connections

LED BackLight Driver 14pin connectors is shown in the table 4.

Table 3. Module connector pin configuration

No	Symbol	Description	No	Symbol	Description
1	GND	Ground	27	Bit Select	'H' or NC= 10bit(D) , 'L' = 8bit
2	NC	No Connection	28	R2AN	SECOND LVDS Receiver Signal (A-)
3	NC	No Connection	29	R2AP	SECOND LVDS Receiver Signal (A+)
4	NC	No Connection	30	R2BN	SECOND LVDS Receiver Signal (B-)
5	NC	No Connection	31	R2BP	SECOND LVDS Receiver Signal (B+)
6	NC	No Connection	32	R2CN	SECOND LVDS Receiver Signal (C-)
7	LVDS Select	'H' =JEIDA , 'L' or NC = VESA	33	R2CP	SECOND LVDS Receiver Signal (C+)
8	VBR EXT	External VBR (From System)	34	GND	Ground
9	OPC OUT	OPC output (From LCM)	35	R2CLKN	SECOND LVDS Receiver Clock Signal(-)
10	OPC Enable	'H' = Enable , 'L' or NC = Disable	36	R2CLKP	SECOND LVDS Receiver Clock Signal(+)
11	GND	Ground	37	GND	Ground
12	R1AN	FIRST LVDS Receiver Signal (A-)	38	R2DN	SECOND LVDS Receiver Signal (D-)
13	R1AP	FIRST LVDS Receiver Signal (A+)	39	R2DP	SECOND LVDS Receiver Signal (D+)
14	R1BN	FIRST LVDS Receiver Signal (B-)	40	R2EN	SECOND LVDS Receiver Signal (E-)
15	R1BP	FIRST LVDS Receiver Signal (B+)	41	R2EP	SECOND LVDS Receiver Signal (E+)
16	R1CN	FIRST LVDS Receiver Signal (C-)	42	Reserved	No connection or GND
17	R1CP	FIRST LVDS Receiver Signal (C+)	43	Reserved	No connection or GND
18	GND	Ground	44	GND	Ground
19	R1CLKN	FIRST LVDS Receiver Clock Signal(-)	45	GND	Ground
20	R1CLKP	FIRST LVDS Receiver Clock Signal(+)	46	GND	Ground
21	GND	Ground	47	NC	No connection
22	R1DN	FIRST LVDS Receiver Signal (D-)	48	VLCD	Power Supply +12.0V
23	R1DP	FIRST LVDS Receiver Signal (D+)	49	VLCD	Power Supply +12.0V
24	R1EN	FIRST LVDS Receiver Signal (E-)	50	VLCD	Power Supply +12.0V
25	R1EP	FIRST LVDS Receiver Signal (E+)	51	VLCD	Power Supply +12.0V
26	Reserved	No connection or GND	-	-	-

Notes:

- 1.All GND(ground) pins should be connected together and should also be connected to the LCD's metal frame.
- 2.All VCC(power input) pins should be connected together.
- 3.All NC pins should be separated from other signal or power.



BR550D15(AU)

Product Specification

LCD Connector(CN2): FI-RE41S-HF, Refer to below table

No	Symbol	Description	No	Symbol	Description
1	NC	No connection(Reserved)	22	RE3N	THIRD LVDS Receiver Signal (E-)
2	NC	No connection	23	RE3P	THIRD LVDS Receiver Signal (E+)
3	NC	No connection	24	GND	Ground
4	NC	No connection	25	GND	Ground
5	NC	No connection	26	RA4N	FOURTH LVDS Receiver Signal (A-)
6	NC	No connection	27	RA4P	FOURTH LVDS Receiver Signal (A+)
7	NC	No connection	28	RB4N	FOURTH LVDS Receiver Signal (B-)
8	NC	No connection	29	RB4P	FOURTH LVDS Receiver Signal (B+)
9	GND	Ground	30	RC4N	FOURTH LVDS Receiver Signal (C-)
10	RA3N	THIRD LVDS Receiver Signal (A-)	31	RC4P	FOURTH LVDS Receiver Signal (C+)
11	RA3P	THIRD LVDS Receiver Signal (A+)	32	GND	Ground
12	RB3N	THIRD LVDS Receiver Signal (B-)	33	RCLK4N	FOURTH LVDS Receiver Clock Signal(-)
13	RB3P	THIRD LVDS Receiver Signal (B+)	34	RCLK4P	FOURTH LVDS Receiver Clock Signal(+)
14	RC3N	THIRD LVDS Receiver Signal (C-)	35	GND	Ground
15	RC3P	THIRD LVDS Receiver Signal (C+)	36	RD4N	FOURTH LVDS Receiver Signal (D-)
16	GND	Ground	37	RD4P	FOURTH LVDS Receiver Signal (D+)
17	RCLK3N	THIRD LVDS Receiver Clock Signal(-)	38	RE4N	FOURTH LVDS Receiver Signal (E-)
18	RCLK3P	THIRD LVDS Receiver Clock Signal(+)	39	RE4P	FOURTH LVDS Receiver Signal (E+)
19	GND	Ground	40	GND	Ground
20	RD3N	THIRD LVDS Receiver Signal (D-)	41	GND	Ground
21	RD3P	THIRD LVDS Receiver Signal (D+)	-		

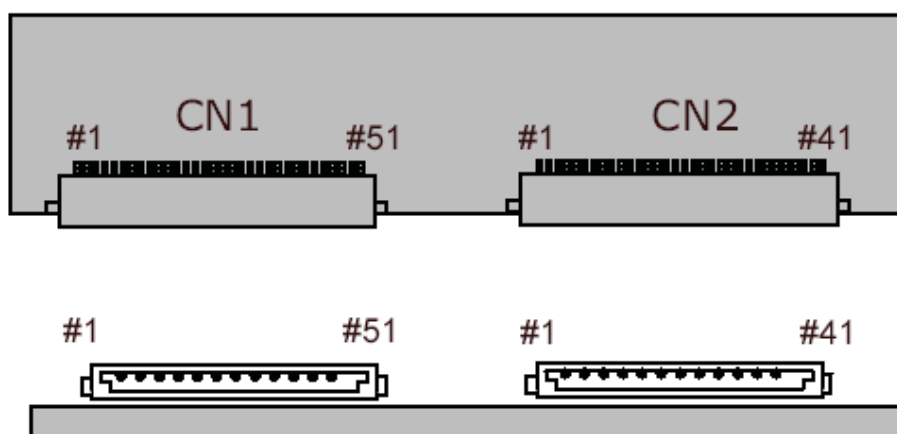

Rear view of LCM



BR550D15(AU)

Product Specification

Table 4. LED Backlight Driver connector pin configuration

Pin No	Symbol	Description	Board A (CN1101) Board B (CN2101)	Board A (CN1106) Board B (CN2106)	Note
1	VBL	Power Supply +24.0V	VBL	VBL	
2	VBL	Power Supply +24.0V	VBL	VBL	
3	VBL	Power Supply +24.0V	VBL	VBL	
4	VBL	Power Supply +24.0V	VBL	VBL	
5	VBL	Power Supply +24.0V	VBL	VBL	
6	GND	Backlight Ground	GND	GND	1
7	GND	Backlight Ground	GND	GND	
8	GND	Backlight Ground	GND	GND	
9	GND	Backlight Ground	GND	GND	
10	GND	Backlight Ground	GND	GND	
11	NC	No connection	OPEN or GND	Don't Care	
12	VON/OFF	Backlight ON/OFF control	VON/OFF	Don't Care	
13	EXTVBR-B	External PWM	EXTVBR-B		2
14	GND	Backlight Ground	GND		3

Notes:

1. The backlight ground should be common with LCD metal frame.
2. This Pin support Linear Dim Voltage control brightness.

Voltage	Function	Voltage	Function
0V	Minimum Duty (10%)	3.3V	Maximum Duty (100%)

3. #14 pin Must be Connected to GND.



BR550D15(AU)

Product Specification

3-3. Power Sequence

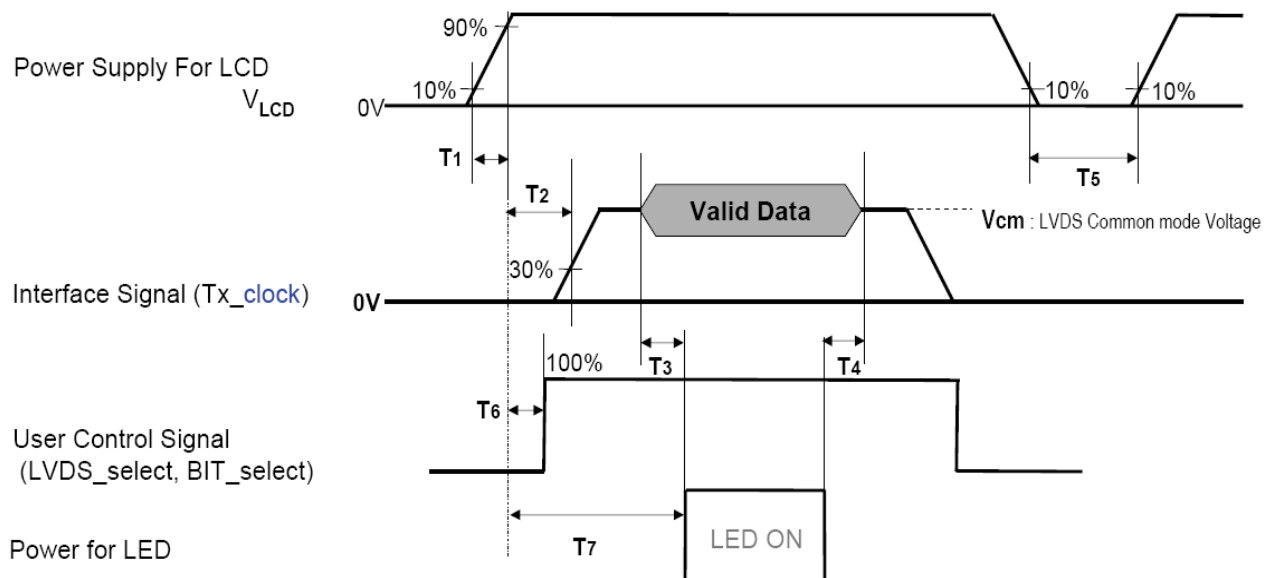

Table 5. Power sequence time delay

Parameter	Values			Units
	Min	Type	Max	
T1	0.5	-	20	ms
T2	0.5	-	-	ms
T3	200	-	-	ms
T4	200	-	-	ms
T5	2.0	-	T2	s
T6	-	-	-	ms
T7	0.5	-	-	s

Notes:

1. Please avoid floating state of interface signal at invalid period.
2. When the interface signal is invalid, be sure to pull down the power supply for LCD VCC to 0V.
3. Lamp power must be turn on after power supply for LCD and interface signals are valid.



BR550D15(AU)

Product Specification

4. Optical Specifications

Optical characteristics are determined after the unit has been 'ON' and stable for approximately 30 minutes in a dark environment at 25 °C. The values specified are measured at an approximate distance 50cm from the LCD surface at a viewing angle 0 °.

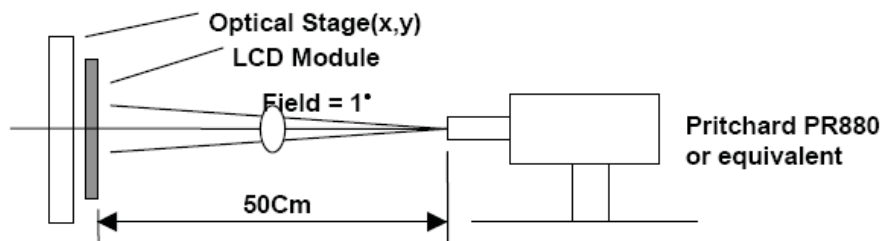

[Figure 9] Optical characteristic measurement equipment and method

Table 6. Optical characteristics

Parameter	Symbol	Values			Units
		Min	Type	Max	
Contrast ratio	CR	1000	1400	-	
Surface luminance, white	L _{wH}	1350	1500	-	cd/m ²
White luminance uniformity	ΔY	80	85	-	%
Response time	G to G	-	5.5	-	ms
Color Temperature			10000		K
Color Gamut(NTSC %)			72		%
Viewing angle (by CR >10)	x axis, right(φ =0°)	-	89	-	degree
	x axis, left (φ =180°)	-	89	-	
	y axis, up (φ =90°)	-	89	-	
	y axis, down (φ =270°)	-	89	-	

Notes:

1. Contrast Ratio(CR) is defined mathematically as :

$$CR = \text{Surface Luminance at all white pixels} / \text{Surface Luminance at all black pixels}$$

It is measured at center 1-point.

2. Surface luminance is determined after the unit has been 'ON' and 1Hour after lighting the backlight in a dark environment at 25±2° C. Surface luminance is the luminance value at center 1-point across the LCD surface 50cm from the surface with all pixels displaying L255 white.

3. The White luminance uniformity on LCD surface is then expressed as :

$$\Delta Y = (\text{Minimum Luminance of 9points} / \text{Maximum Luminance of 9points}) * 100$$



BR550D15(AU)

Product Specification

5. Mechanical Characteristics

Table 7. provides general mechanical characteristics for the model BR550D15. Please refer to Figure 15,16 regarding the detailed mechanical drawing of the LCD.

Table 7. Mechanical characteristics

Outside dimensions	Horizontal	1286.0mm
	Vertical	745.0mm
	Depth	60.0mm
Active display area	Horizontal	1209.6mm
	Vertical	680.4mm
Weight(approximate)	19.5Kg(Typ.), 21Kg(Max.)	
Surface Treatment	Hard coating(3H) Anti-glare treatment of the front polarizer	