



BR720D25(LG)

Product Specification

**SPECIFICATION
FOR
APPROVAL**

Title	72.0" WUXGA TFT LCD
-------	---------------------

BUYER	
MODEL	BR720D25
SUFFIX	LG



BR720D25(LG)

Product Specification

1. General Description

The BR720D25 is a Color Active Matrix Liquid Crystal Display with an integral Light Emitting Diode (LED) backlight system. The matrix employs a-Si Thin Film Transistor as the active element.

It is a transmissive type display operating in the normally black mode. This TFT-LCD has a 72.07 inch diagonal measured active display area with WUXGA resolution(1080 vertical by 1920 horizontal pixel array) Each pixel is divided into Red, Green and Blue sub-pixels or dots which are arranged in vertical stripes.

Gray scale or the brightness of the sub-pixel color is determined with a 10-bit gray scale signal for each dot, thus, presenting a palette of more than 1.06Billion colors.

It is intended to support Public Display where high brightness, super wide viewing angle, high color gamut, high color depth and fast response time are important.

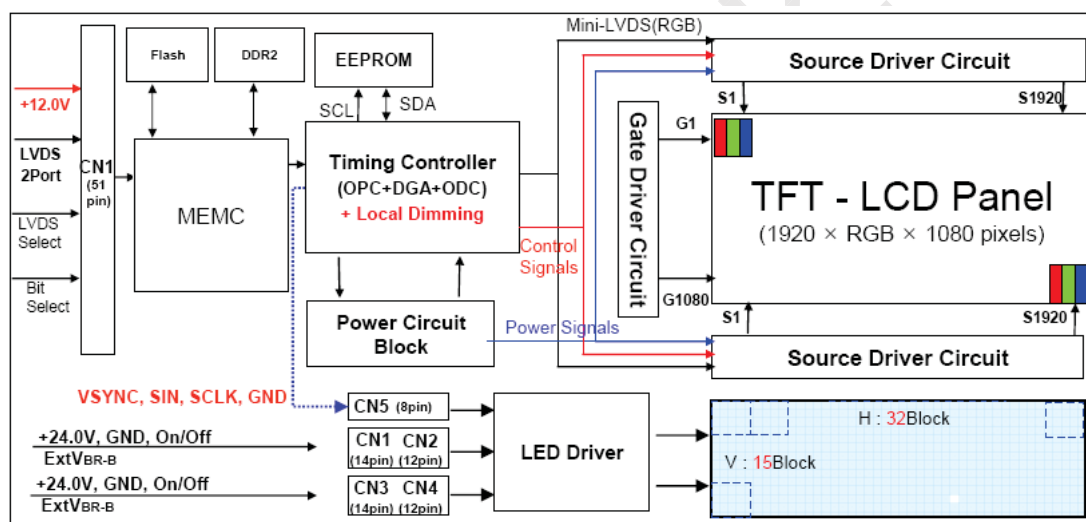

General Features

Active screen size	72.07 inch (1830.616mm) diagonal	
Outline Dimension	1666.0(H) x 968.0(V) x 60.0(D) mm(Typ.)	
Active Area	1595.52(H) x 897.48(V) mm	
Pixel Pitch	0.831 mm x 0.831 mm	
Pixel Format	1920 horiz. by 1080 vert. Pixels. RGB stripe arrangement	
Display Colors	10bit 1.06Billion colors	
Luminance, white	2500 cd/m2(Typ. Center 1 point)	
Power Consumption	1392.8 W	Watts(Typ.) (PDD=22.8W PBL=1370W)
Weight	39Kg (Typ.)	
Display operating mode	Transmissive mode, normally black	
Surface treatments	Hard coating (3H), Anti-glare treatment of the front polarizer	



BR720D25(LG)

Product Specification

2. Absolute maximum ratings

The following are maximum values which, if exceeded, may cause faulty operation or damage to the unit.

Table 1. Absolute Maximum Ratings

Parameter	Symbol	Values		Units	Notes
		Min	Max		
Power Supply Input Voltage	V _{CC}	-0.3	+14.0	V _{dc}	At 25 °C
Operating Temperature	T _{OP}	0	+50	°C	1
Storage Temperature	T _{ST}	-20	+60	°C	1
Operating Ambient Humidity	H _{OP}	10	+90	%RH	1
Storage Humidity	H _{ST}	10	+90	%RH	1

Note : 1. Temperature and relative humidity range are shown in the figure below. Wet bulb temperature should be 39 °C Max, and no condensation of water.

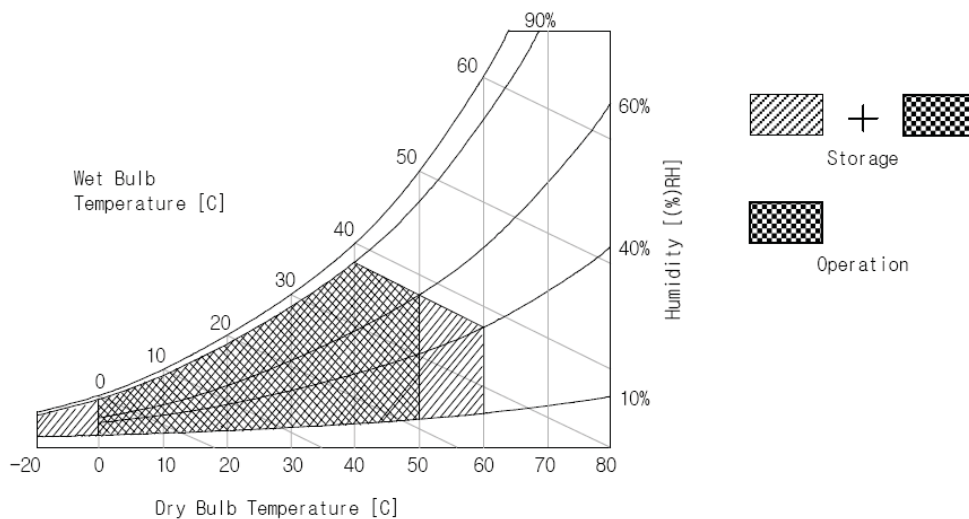

Figure 2. Temperature and relative humidity



BR720D25(LG)

Product Specification

3. Electrical specifications

3-1. Electrical characteristics

The BR720D25 requires two power inputs. One is employed to power the LCD electronics and to drive the TFT array and liquid crystal. Another which powers the LED Backlight .LED Driver is an internal unit to the LCD.

Table 2. Electrical Characteristics

Parameter	Symbol	Values			Units	Notes
		Min	Type	Max		
Power Supply Input Voltage	V _{CC}	10.8	12.0	13.2	V	
Permissive Power Input Ripple	V _{RF}	-	-	0.1	V	
Power Supply Input Current	I _{CC}	-	1.035	2.550	A	1
Power Consumption	P _C	-	13.2	32.4	Watts	
In Rush Current	I _{RUSH}	-	-	10	A	2
LED Power supply Voltage	V _{BL}	22.8	24	-	V	3
LED Power Supply current	I _{BL}	-	57.1	-	A	
LED BL Power Consumption	P _{BL}	-	1370	-	Watts	4
Brightness Adjust	V _{BR-B}	10	-	100	%	On Duty
Linear Brightness Adjust	V _{BR-A}	0	-	3.3	V	
Life Time		50,000			Hrs	5

Note: Do not attach a conducting tape to lamp connecting wire. If the lamp wire attach to conducting tape TFT-LCD Module have a low luminance.

- 1.The specified current and power consumption are under the V_{CC}=12.0V, 25°C, f_v (frame frequency)=240Hz condition.
- 2.The duration of rush current is about 2ms. And V_{CC} rise time is 500us ± 20%.
- 3.Operating voltage is measured under 25°C.
- 4.The LED Backlight power consumption shown above include LED Diver Module under 25°C.
- 5.The life time is determined as the time at which brightness of lamp is 50% compared to that of initial value at the typical lamp current on condition of continuous operating at 25°C.



BR720D25(LG)

Product Specification

3-2. Interface Connections

This LCD module employs three kinds of interface connection, 51-pin connector are used for the module electronics and 14-pin connector is used for the integral backlight system.

-LCD Connector : FI-R51S-HF(manufactured by JAE) or compatible

Refer to below and next Page

table-Mating Connector : FI-R51HL(JAE) or compatible

LED BackLight Driver 14pin connectors is shown in the table 4.

Table 3. Module connector pin configuration

No	Symbol	Description	No	Symbol	Description
1	NC	No Connection (Reserved for LGD)	27	Bit Select	H or NC=10bit(D), "L" = 8bit
2	NC	No Connection (Reserved for LGD)	28	R2AN	SECOND LVDS Receiver Signal (A-)
3	NC	No Connection (Reserved for LGD)	29	R2AP	SECOND LVDS Receiver Signal (A+)
4	NC	No Connection (Reserved for LGD)	30	R2BN	SECOND LVDS Receiver Signal (B-)
5	NC	No Connection (Reserved for LGD)	31	R2BP	SECOND LVDS Receiver Signal (B+)
6	NC	No Connection (Reserved for LGD)	32	R2CN	SECOND LVDS Receiver Signal (C-)
7	LVDS Select	'H' =JEIDA , Fix	33	R2CP	SECOND LVDS Receiver Signal (C+)
8	NC	No Connection (Reserved for LGD)	34	GND	Ground
9	NC	No Connection (Reserved for LGD)	35	R2CLKN	SECOND LVDS Receiver Clock Signal(-)
10	NC	No Connection (Reserved for LGD)	36	R2CLKP	SECOND LVDS Receiver Clock Signal(+)
11	GND	Ground	37	GND	Ground
12	R1AN	FIRST LVDS Receiver Signal (A-)	38	R2DN	SECOND LVDS Receiver Signal (D-)
13	R1AP	FIRST LVDS Receiver Signal (A+)	39	R2DP	SECOND LVDS Receiver Signal (D+)
14	R1BN	FIRST LVDS Receiver Signal (B-)	40	R2EN	SECOND LVDS Receiver Signal (E-)
15	R1BP	FIRST LVDS Receiver Signal (B+)	41	R2EP	SECOND LVDS Receiver Signal (E+)
16	R1CN	FIRST LVDS Receiver Signal (C-)	42	NC	No Connection
17	R1CP	FIRST LVDS Receiver Signal (C+)	43	NC	No Connection
18	GND	Ground	44	GND	Ground
19	R1CLKN	FIRST LVDS Receiver Clock Signal(-)	45	GND	Ground
20	R1CLKP	FIRST LVDS Receiver Clock Signal(+)	46	GND	Ground
21	GND	Ground	47	NC	No connection
22	R1DN	FIRST LVDS Receiver Signal (D-)	48	VLCD	Power Supply +12.0V
23	R1DP	FIRST LVDS Receiver Signal (D+)	49	VLCD	Power Supply +12.0V
24	R1EN	FIRST LVDS Receiver Signal (E-)	50	VLCD	Power Supply +12.0V
25	R1EP	FIRST LVDS Receiver Signal (E+)	51	VLCD	Power Supply +12.0V
26	NC	No Connection	-	-	-

Notes:

- 1.All GND(ground) pins should be connected together and should also be connected to the LCD's metal frame.
- 2.All VCC(power input) pins should be connected together.



BR720D25(LG)

Product Specification

3.All NC pins should be separated from other signal or power.

Table 4. LED Backlight Driver connector pin configuration

Pin No	Symbol	Description	Board A (CN1101) Board B (CN2101)	Board A (CN1106) Board B (CN2106)	Note
1	VBL	Power Supply +24.0V	VBL	VBL	
2	VBL	Power Supply +24.0V	VBL	VBL	
3	VBL	Power Supply +24.0V	VBL	VBL	
4	VBL	Power Supply +24.0V	VBL	VBL	
5	VBL	Power Supply +24.0V	VBL	VBL	
6	GND	Backlight Ground	GND	GND	1
7	GND	Backlight Ground	GND	GND	
8	GND	Backlight Ground	GND	GND	
9	GND	Backlight Ground	GND	GND	
10	GND	Backlight Ground	GND	GND	
11	NC	No connection	OPEN or GND	Don't Care	
12	VON/OFF	Backlight ON/OFF control	VON/OFF	Don't Care	
13	EXTVBR-B	External PWM	EXTVBR-B		2
14	GND	Backlight Ground	GND		3

Notes:

1. The backlight ground should be common with LCD metal frame.
2. This Pin support Linear Dim Voltage control brightness.

Voltage	Function	Voltage	Function
0V	Minimum Duty (10%)	3.3V	Maximum Duty (100%)

3. #14 pin Must be Connected to GND.



BR720D25(LG)

Product Specification

3-3. Power Sequence

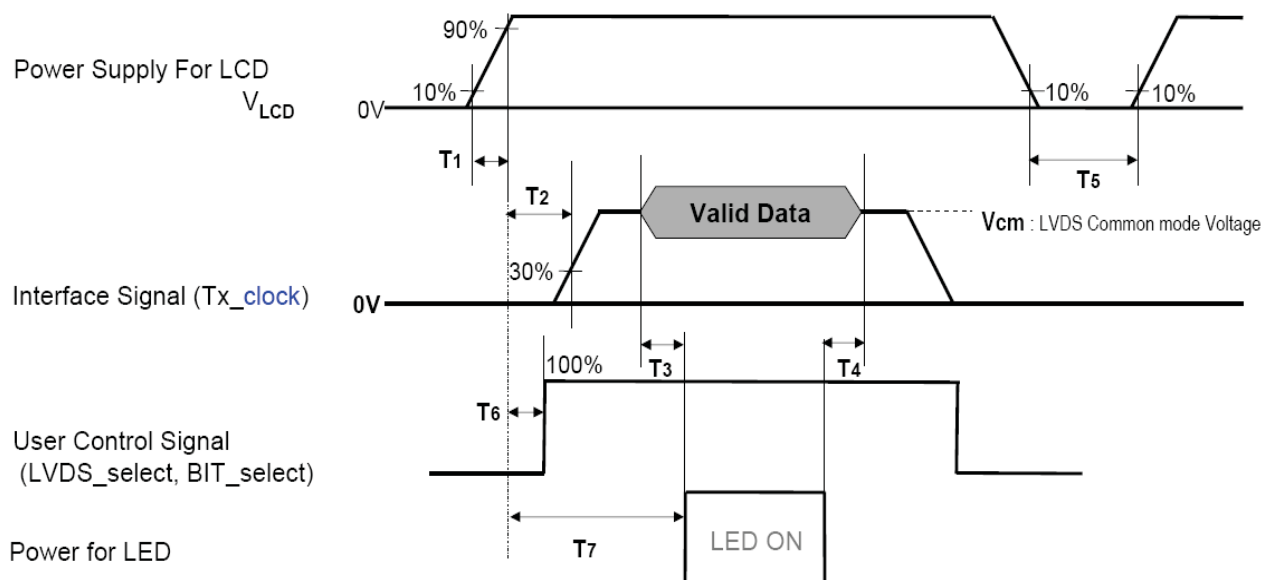

Table 5. Power sequence time delay

Parameter	Values			Units
	Min	Type	Max	
T1	0.5	-	20	ms
T2	0	-	-	ms
T3	200	-	-	ms
T4	200	-	-	ms
T5	1.0	-	-	s
T6	-	-	T2	ms
T7	0.5	-	-	s

Notes:

1. Please avoid floating state of interface signal at invalid period.
2. When the interface signal is invalid, be sure to pull down the power supply for LCD VCC to 0V.
3. Lamp power must be turn on after power supply for LCD and interface signals are valid.



BR720D25(LG)

Product Specification

4. Optical Specifications

Optical characteristics are determined after the unit has been 'ON' and stable for approximately 30 minutes in a dark environment at 25 °C. The values specified are measured at an approximate distance 50cm from the LCD surface at a viewing angle 0 °.

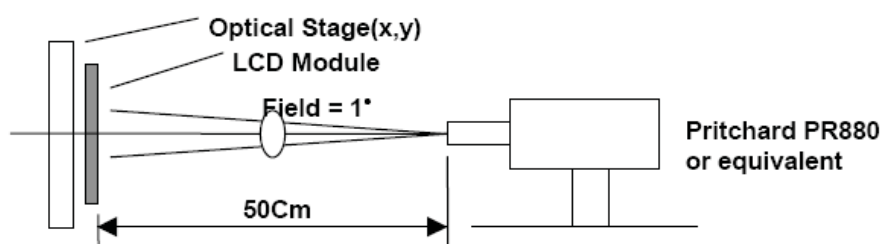

[Figure 9] Optical characteristic measurement equipment and method

Table 6. Optical characteristics

Parameter	Symbol	Values			Units
		Min	Type	Max	
Contrast ratio	CR	900	1100	-	
Surface luminance, white	L_{wh}	2350	2500	-	cd/m ²
White luminance uniformity	ΔY	80	85	-	%
Response time	G to G	-	9	15	ms
Color Temperature			10000		K
Color Gamut(NTSC %)			72		%
Viewing angle (by CR >10)	x axis, right($\phi = 0^\circ$)	-	89	-	degree
	x axis, left ($\phi = 180^\circ$)	-	89	-	
	y axis, up ($\phi = 90^\circ$)	-	89	-	
	y axis, down ($\phi = 270^\circ$)	-	89	-	

Notes:

1. Contrast Ratio(CR) is defined mathematically as :

$$CR = \text{Surface Luminance at all white pixels} / \text{Surface Luminance at all black pixels}$$

It is measured at center 1-point.

2. Surface luminance is determined after the unit has been 'ON' and 1 Hour after lighting the backlight in a dark environment at $25 \pm 2^\circ$ C. Surface luminance is the luminance value at center 1-point across the LCD surface 50cm from the surface with all pixels displaying L255 white.

3. The White luminance uniformity on LCD surface is then expressed as :

$$\Delta Y = (\text{Minimum Luminance of 9points} / \text{Maximum Luminance of 9points}) * 100$$



BR720D25(LG)

Product Specification

5. Mechanical Characteristics

Table 7. provides general mechanical characteristics for the model BR720D25. Please refer to Figure 15,16 regarding the detailed mechanical drawing of the LCD.

Table 7. Mechanical characteristics

Outside dimensions	Horizontal	1666.0mm
	Vertical	968.0mm
	Depth	60.0mm
Active display area	Horizontal	1595.52mm
	Vertical	897.48mm
Weight(approximate)	39Kg(Typ.), 39.5Kg(Max.)	
Surface Treatment	Hard coating(3H) Anti-glare treatment of the front polarizer	