

用途：用于高功率 DC/DC 转换和功率开关。

Purpose: These devices are well suited for high efficiency switching DC/DC converters and switch mode power supplies.

特点：低栅电荷, 低反馈电容, 开关速度快。

Features: Low gate charge , low crss, fast switching.

极限参数/Absolute maximum ratings(Ta=25°C)

参数符号 Symbol	数值 Rating	单位 Unit
V _{DSS}	600	V
I _D (Tc=25°C)	2.0	A
I _D (Tc=100°C)	1.3	A
I _{DM}	6.0	A
V _{GSS}	±30	V
E _{AS}	120	mJ
E _{AR}	5.4	mJ
I _{AR}	2.0	A
P _D (Tc=25°C)	23	W
T _J , T _{STG}	-55 to 150	°C

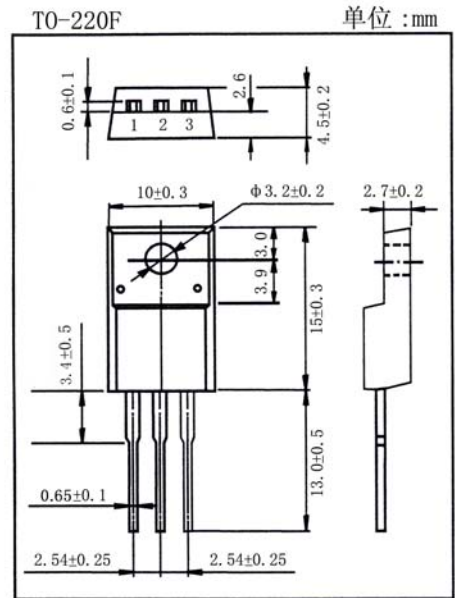

引脚： 1.G 2.D 3.S

电性能参数/Electrical Characteristics(Ta=25°C)

参数符号 Symbol	测试条件 Test Conditions	最小值 Min	典型值 Typ	最大值 Max	单位 Unit
BV _{DSS}	V _{GS} =0V I _D =250 μ A	600			V
I _{DSS}	V _{DS} =600V V _{GS} =0V			1.0	μ A
	V _{DS} =480V T _C =125°C			100	μ A
I _{GSS}	V _{GS} =±30V V _{DS} =0V			±0.1	μ A
V _{GS(th)}	V _{DS} =V _{GS} I _D =250 μ A	2.0		4.0	V
R _{DS(on)}	V _{GS} =10V I _D =1.0A		4.0	5.0	Ω
g _{FS}	V _{DS} =40V I _D =1.0A		2.05		S
V _{SD}	V _{GS} =0V I _S =2.0A			1.4	V
C _{iss}	V _{DS} =25V V _{GS} =0V f=1.0MHz		320	420	pF
C _{oss}			35	46	pF
C _{rss}			4.5	6.0	pF
t _{d(on)}	V _{DD} =300V I _D =2.0A R _C =25 Ω		8.0	30	ns
t _r			23	60	ns
t _{d(off)}			25	60	ns
t _f			28	70	ns

BRF2N60 (CS2N60F)

