

描述 / Descriptions

TO-220FL 塑封封装 N 沟道 MOS 场效应管。N-CHANNEL MOSFET in a TO-220FL Plastic Package.

特征 / Features

600V 超结功率场效应管, $R_{DS(on)} \times Q_g$ 很低, 100%雪崩测试, 符合 RoHS 要求。

600V Super-Junction Power MOSFET. Very Low $R_{DS(on)} \times Q_g$, 100%avalanche tested, RoHS compliant.

用途 / Applications

用于开关电源、不间断电源、功率因数校正。

Switch Mode Power Supply, Uninterruptible Power Supply, Power Factor Correction.

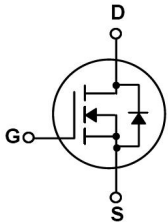
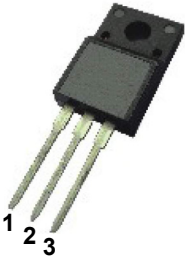
内部等效电路 / Equivalent Circuit**引脚排列 / Pinning**

PIN1 : G

PIN 2 : D

PIN 3 : S

放大及印章代码 / h_{FE} Classifications & Marking

见印章说明。 See Marking Instructions.

极限参数 / Absolute Maximum Ratings(Ta=25°C)

参数 Parameter	符号 Symbol	数值 Rating	单位 Unit
Drain-Source Voltage	V_{DSS}	600	V
Drain Current	I_D	20	A
Drain Current – Pulsed (note1)	I_{DM}	60	A
Gate-Source Voltage	V_{GS}	±30	V
Single Pulsed Avalanche Energy (note2)	E_{AS}	50	mJ
Repetitive Avalanche Energy (note1)	E_{AR}	1.0	mJ
Avalanche Current (note1)	I_{AR}	20	A
Power Dissipation	P_D	34.5	W
Thermal Resistance - Junction to Ambient	$R_{\theta JA}$	80	°C/W
Thermal Resistance, Junction-to-Case	$R_{\theta JC}$	3.6	°C/W
Operating and Storage Temperature Range	T_J, T_{STG}	-55 to 150	°C

电性能参数 / Electrical Characteristics(Ta=25°C)

参数 Parameter	符号 Symbol	测试条件 Test Conditions	最小值 Min	典型值 Typ	最大值 Max	单位 Unit
Drain-Source Breakdown Voltage	BV_{DSS}	$V_{GS}=0V$ $I_D=250\mu A$	600			V
Zero Gate Voltage Drain Current	I_{DSS}	$V_{DS}=600V$ $V_{GS}=0V$ $T_J=25^\circ C$			1.0	μA
		$V_{DS}=600V$ $V_{GS}=0V$ $T_J=150^\circ C$			100	
Gate-Body Leakage Current, Forward	I_{GSS}	$V_{GS}=\pm 30V$ $V_{DS}=0V$			±100	nA
Gate Threshold Voltage	$V_{GS(th)}$	$V_{DS}=V_{GS}$ $I_D=250\mu A$	2.5		3.5	V
Static Drain-Source On-Resistance (note3)	$R_{DS(on)}$	$V_{GS}=10V$ $I_D=10A$		0.17	0.19	Ω
Forward Transconductance (note3)	g_{FS}	$V_{DS}=10V$ $I_D=20A$		18.8		S
Drain-Source Diode Forward Voltage	V_{SD}	$V_{GS}=0V$ $I_{SD}=20A$ $T_J=25^\circ C$		0.95	1.2	V
Input Capacitance	C_{iss}	$V_{DS}=50V$ $V_{GS}=0V$ $f=1.0MHz$		2140		μF
Output Capacitance	C_{oss}			300		
Reverse Transfer Capacitance	C_{rss}			18		
Turn-On Delay Time	$t_{d(on)}$	$V_{DD}=300V$ $I_D=20A$ $R_G=25\Omega$		48	104	ns
Turn-On Rise Time	t_r			108	220	
Turn-Off Delay Time	$t_{d(off)}$			176	360	
Turn-Off Fall Time	t_f			50	108	

电性能参数 / Electrical Characteristics(Ta=25°C)

参数 Parameter	符号 Symbol	测试条件 Test Conditions	最小值 Min	典型值 Typ	最大值 Max	单位 Unit
Total Gate Charge	Q_g	$V_{DD}=480V$ $I_D=20A$ $V_{GS}=10V$		54		nC
Gate-Source Charge	Q_{gs}			10		
Gate-Drain Charge	Q_{gd}			20		
Continuous Body Diode Current	I_S	$T_C=25^\circ C$			20	A
Pulsed Diode Forward Current	I_{SM}				60	
Reverse Recovery Time	T_{rr}	$V_R=480V$ $I_F=I_S$ $di_F/dt=100A/\mu S$		400		ns
Reverse Recovery Charge	Q_{rr}			5		μC
Peak Reverse Recovery Current	I_{rrm}				24	

注释/Notes

- 脉冲宽度由最高结温限制
Repetitive Rating: Pulse width limited by maximum junction temperature
- $I_{AS}=10A$, $V_{DD}=50V$, $R_G=25\Omega$, 起始温度 $T_J=25^\circ C$
 $I_{AS}=10A$, $V_{DD}=50V$, $R_G=25\Omega$, Starting $T_J=25^\circ C$
- 脉冲测试: 脉冲宽度 $\leq 300\mu s$, 占空比 $\leq 1\%$
Pulse Test: Pulse width $\leq 300\mu s$, Duty Cycles $\leq 1\%$

电参数曲线图 / Electrical Characteristic Curve

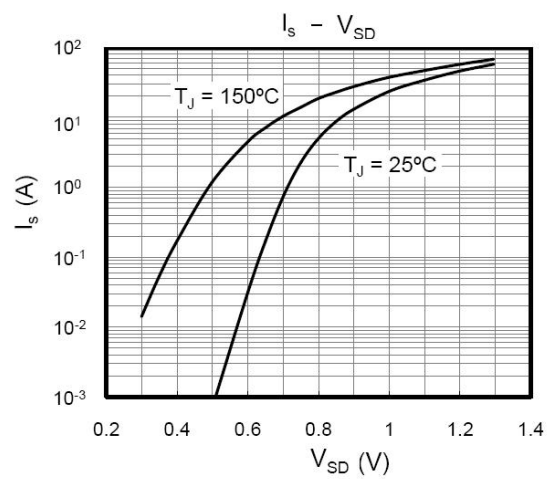
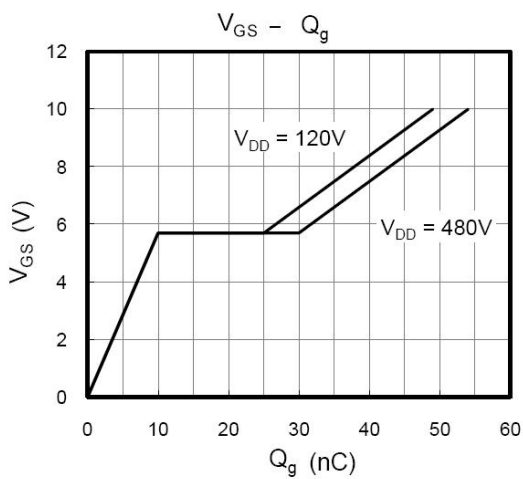
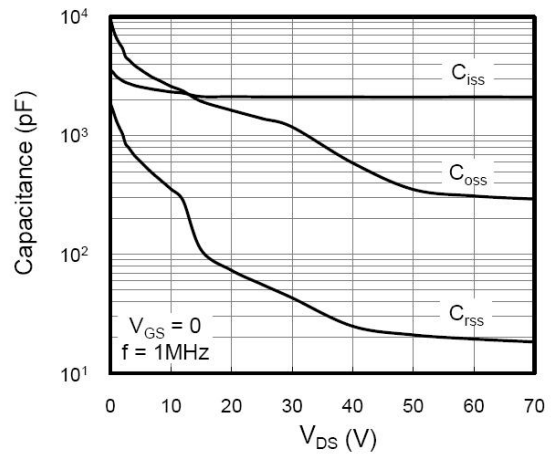
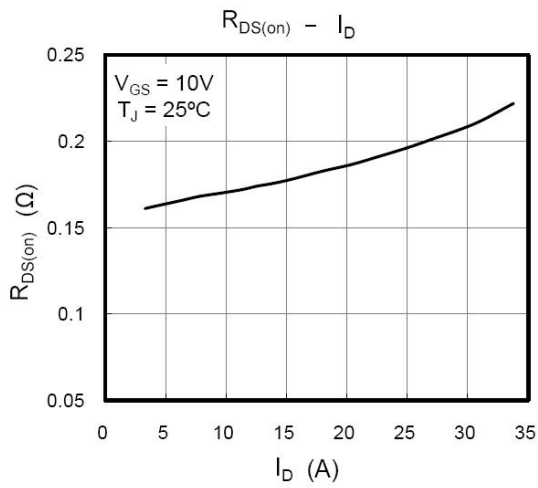
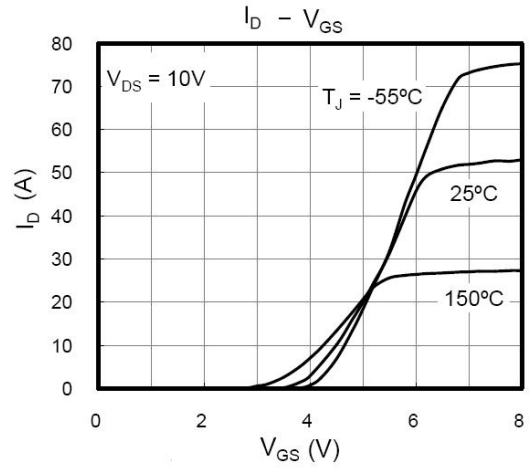
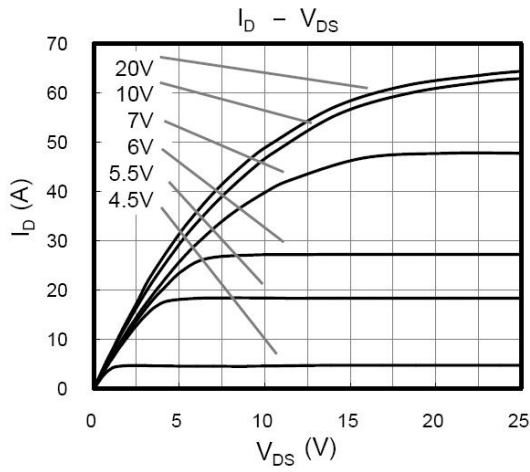

电参数曲线图 / Electrical Characteristic Curve

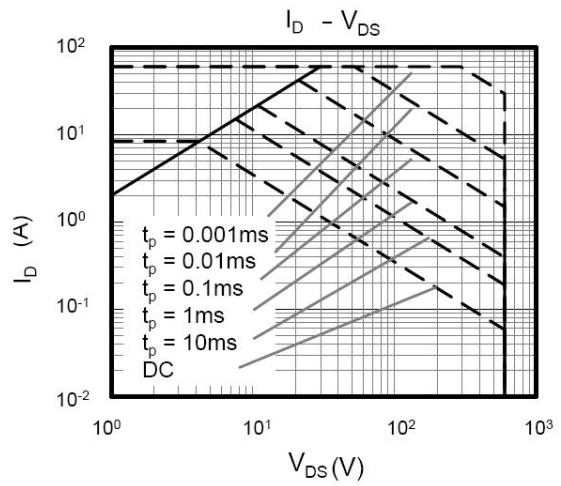
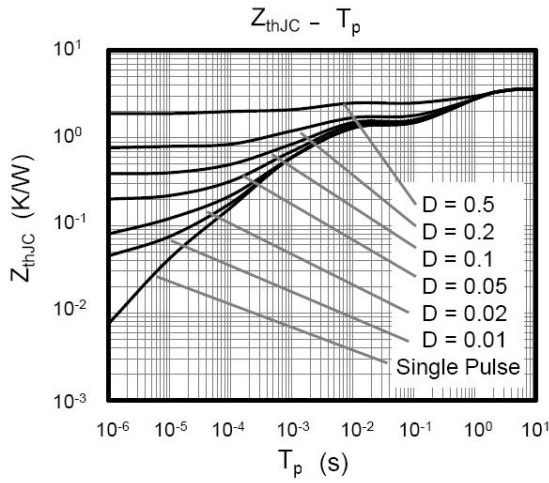
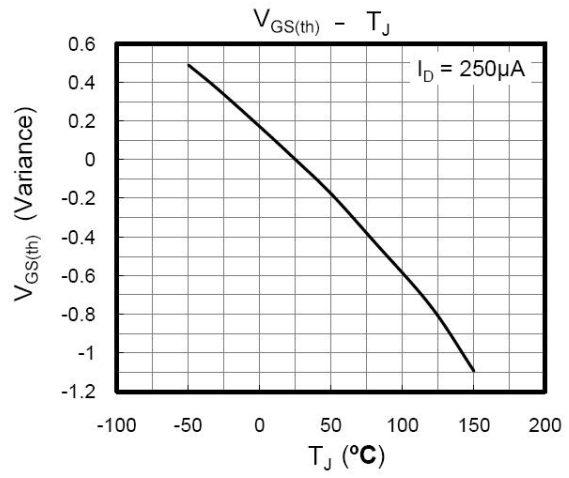
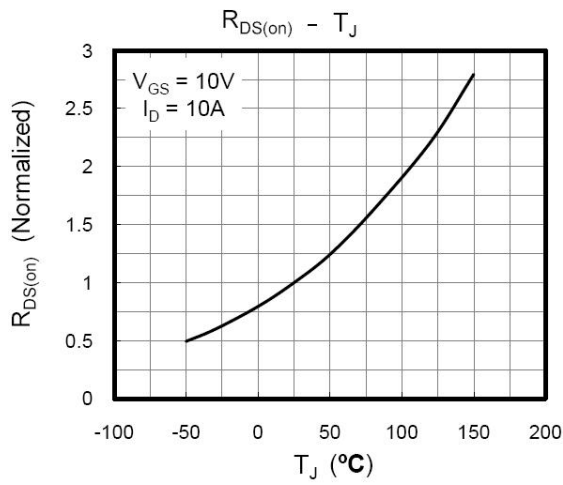

测试电路和波形 / Test Circuit and Waveform

Figure A: Gate Charge Test Circuit and Waveform

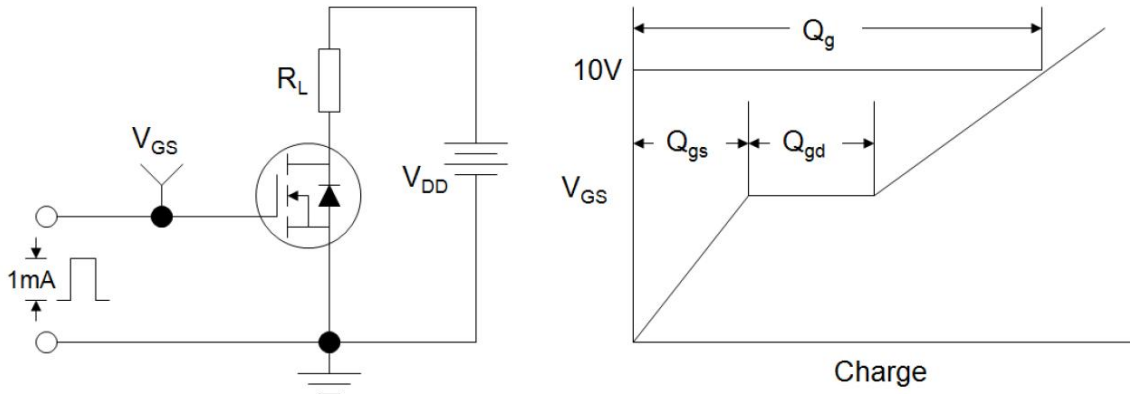

Figure B: Resistive Switching Test Circuit and Waveform

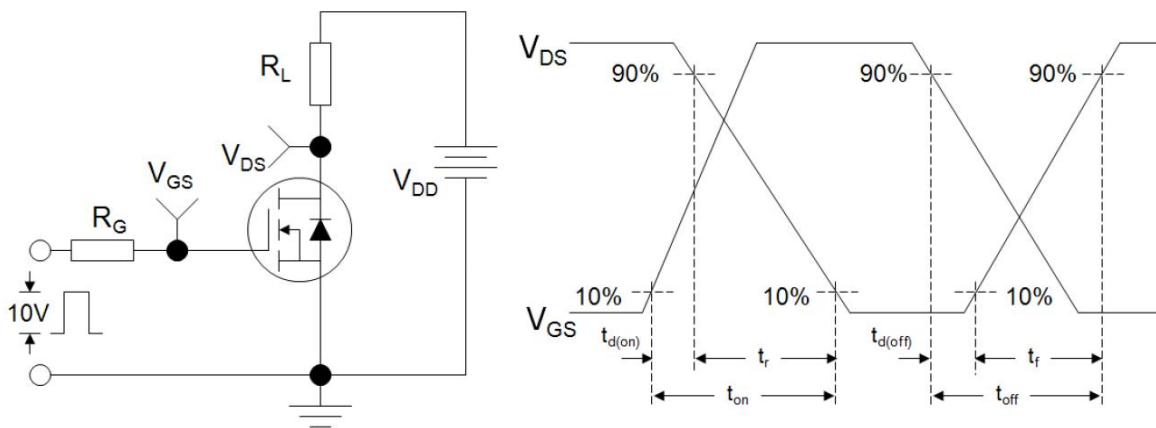
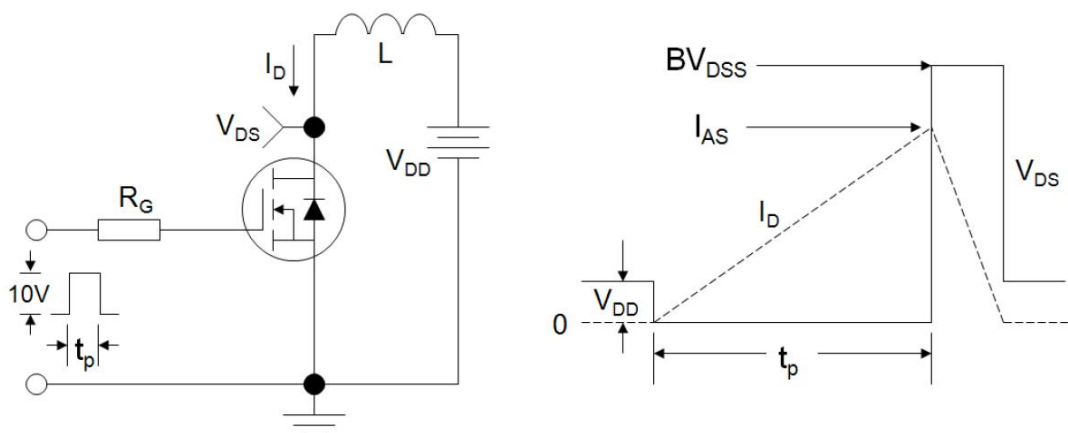

Figure C: Unclamped Inductive Switching Test Circuit and Waveform



外形尺寸图 / Package Dimensions

TO-220FL

单位: mm

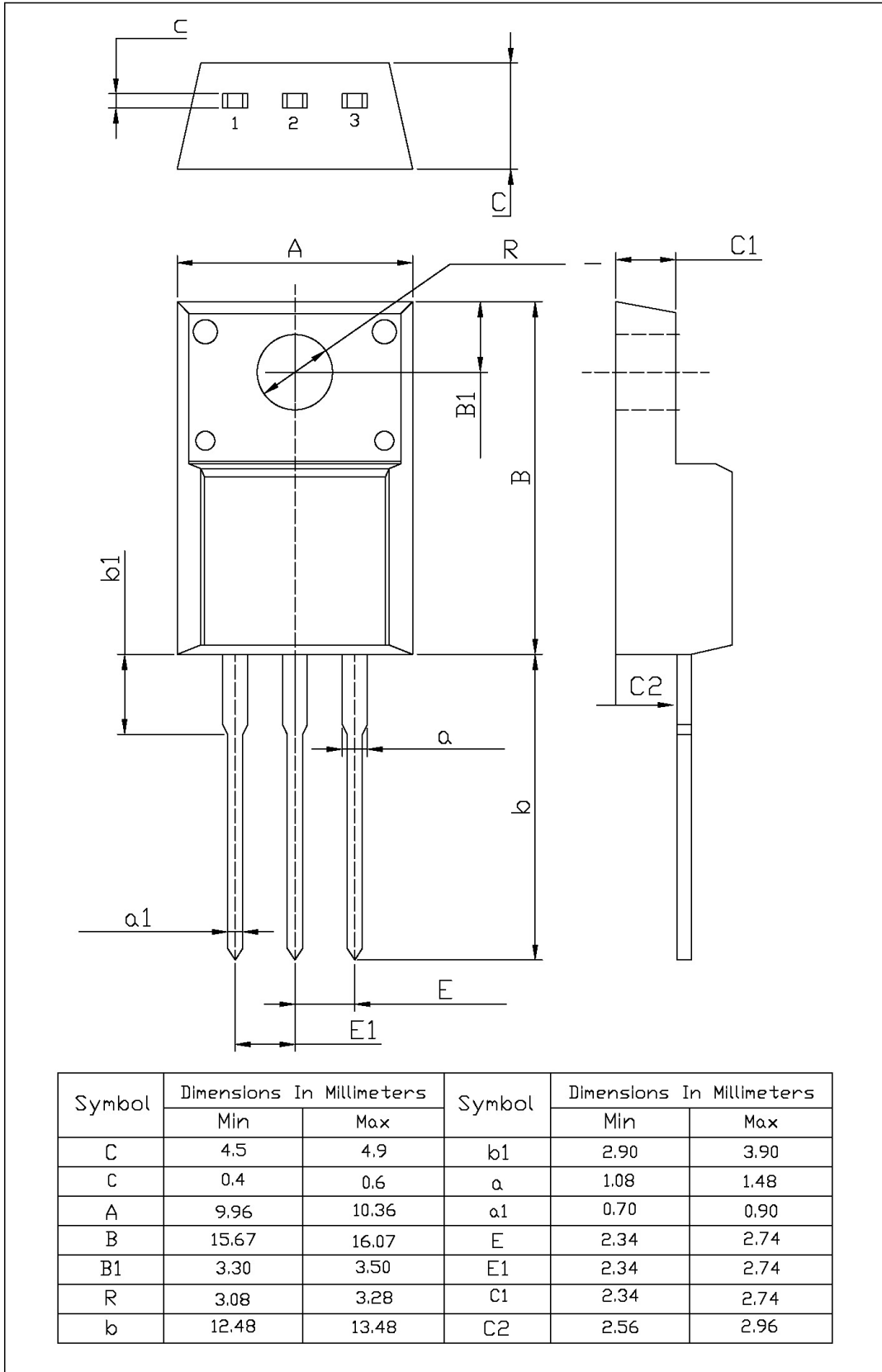

印章说明 / Marking Instructions

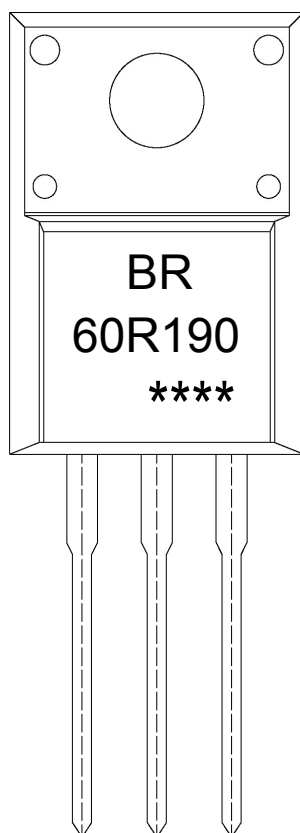

说明：

BR： 为公司代码

60R190： 为型号代码

****： 为生产批号代码，随生产批号变化。

Note:

BR: Company Code

60R190: Product Type.

****: Lot No. Code, code change with Lot No.

波峰焊温度曲线图(无铅) / Temperature Profile for Dip Soldering(Pb-Free)

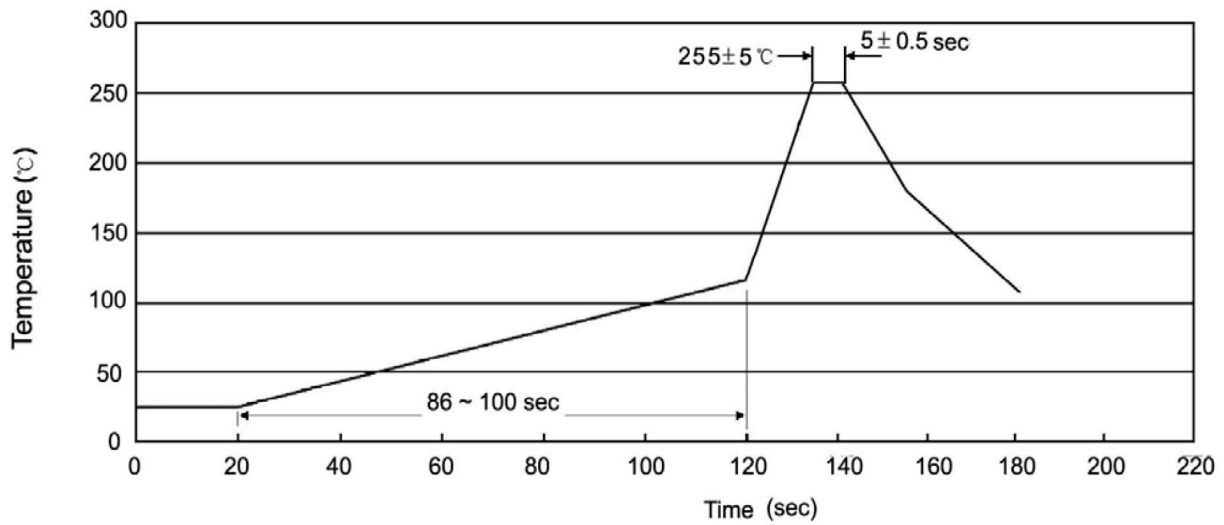

说明：

- 1、预热温度 25 ~ 150°C，时间 60 ~ 90sec;
- 2、峰值温度 255±5°C，时间持续为 5±0.5sec;
- 3、焊接制程冷却速度为 2 ~ 10°C/sec.

Note:

- 1.Preheating:25~150°C, Time:60~90sec.
- 2.Peak Temp.:255±5°C, Duration:5±0.5sec.
3. Cooling Speed: 2~10°C/sec.

耐焊接热试验条件 / Resistance to Soldering Heat Test Conditions

温度：270±5°C

时间：10±1 sec.

Temp.:270±5°C

Time:10±1 sec

包装规格 / Packaging SPEC.

套管包装 / TUBE

Package Type 封装形式	Units 包装数量					Dimension 包装尺寸 (unit: mm ³)		
	Units/Tube 只/套管	Tubes/Inner Box 套管/盒	Units/Inner Box 只/盒	Inner Boxes/Outer Box 盒/箱	Units/Outer Box 只/箱	Tube 套管	Inner Box 盒	Outer Box 箱
TO-220FL	50	20	1,000	5	5,000	532×33×7.0	555×164×50	575×290×180

使用说明 / Notices