

BRG15N120D

Rev.D Oct.-2015

描述 / Descriptions

TO-3P 塑封封装绝缘栅双极晶体管。Insulated-Gate Bipolar Transistor in a TO-3P Plastic Package.

特征 / Features

低栅极电荷、正温度系数、低饱和压降、RoHS 产品。

Low gate charge, , Low saturation voltage ,Positive temperature coefficient, RoHS product.

用途 / Applications

逆变器、变频器、电磁炉、不间断电源。

General purpose inverter, Frequency converters, Induction Heating(IH), Uninterrupted Power Supply(UPS).

内部等效电路 / Equivalent Circuit

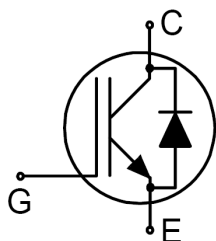

引脚排列 / Pinning

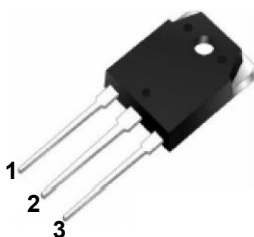

PIN1 : Gate

PIN 2 : Collector

PIN 3 : Emitter

放大及印章代码 / h_{FE} Classifications & Marking

见印章说明。See Marking Instructions.

极限参数 / Absolute Maximum Ratings(Ta=25°C)

参数 Parameter	符号 Symbol	数值 Rating	单位 Unit
Collector-emitter voltage	V_{CES}	1200	V
Gate-emitter voltage	V_{GES}	± 20	V
Collector current	I_C	30	A
Collector current@ $T_C=100^\circ\text{C}$		15	A
Collector peak current, T_P limited by T_{JMAX}	I_{CM}	45	A
Diode forward current@ $T_C=100^\circ\text{C}$	I_F	15	A
Diode maximum forward current	I_{FM}	45	A
Power dissipation($T_C=25^\circ\text{C}$)	P_D	186	W
Power dissipation($T_C=100^\circ\text{C}$)		74	W
Operating junction and storage temperature range	T_J, T_{stg}	-55~150	$^\circ\text{C}$
Maximum temperature for soldering	T_L	300	$^\circ\text{C}$
IGBT thermal resistance,junction-case	$R_{th(j-c)}$	0.67	$^\circ\text{C/W}$
Diode thermal resistance,junction-case	$R_{th(j-c)}$	2.88	$^\circ\text{C/W}$
Thermal resistance,junction-ambient	$R_{th(j-a)}$	40	$^\circ\text{C/W}$

电性能参数 / Electrical Characteristics(Ta=25°C)

参数 Parameter	符号 Symbol	测试条件 Test Conditions	最小值 Min	典型值 Typ	最大值 Max	单位 Unit
Collector-emitter breakdown voltage	V_{CES}	$V_{GE}=0V; I_{CE}=250\mu\text{A}$	1200	-	-	V
Zero gate voltage Collector current	I_{CES}	$V_{GE}=0V; V_{CE}=1200V$	-	-	1	mA
Gate-body leakage current	I_{GES}	$V_{GE}=\pm 20V; V_{CE}=0V$	-	-	± 250	nA
Gate threshold voltage	$V_{GE(th)}$	$I_C=15\text{mA}; V_{CE}=V_{GE}$	5.0	6.4	7.0	V
Collector-emitter saturation voltage	$V_{CE(sat)}$	$I_C=15\text{A}; V_{GE}=15V$	-	2	2.5	V
Input capacitance	C_{ies}	$V_{CE}=30V, V_{GE}=0V, f=1\text{MHz}$	-	2620	-	pF
Output capacitance	C_{oes}		-	67	-	
Reverse transfer capacitance	C_{res}		-	43	-	

电性能参数 / Electrical Characteristics(Ta=25°C)

参数 Parameter	符号 Symbol	测试条件 Test Conditions	最小值 Min	典型值 Typ	最大值 Max	单位 Unit
Turn-on delay time	$t_{d(ON)}$	$V_{CE}=600V$ $I_C=15A$ $R_G=15\Omega$ $V_{GE}=15/0V$ Inductive Load	-	25	-	ns
Rise time	t_r		-	48	-	
Turn-off delay time	$t_{d(OFF)}$		-	155	-	
Fall time	t_f		-	115	-	
Turn-On Switching Loss	E_{on}	$V_{CE}=600V$ $I_C=15A$ $V_{GE}=15V$	-	0.67	-	mJ
Turn-Off Switching Loss	E_{off}		-	0.45	-	
Total Switching Loss	E_{ts}		-	1.12	-	
Total gate charge	Q_G	$V_{CE}=600V$ $I_C=15A$ $V_{GE}=15V$	-	130	180	nC
Gate-emitter charge	Q_{G-E}		-	15	22	
Gate-collector charge	Q_{G-C}		-	50	65	
Diode forward voltage	V_F	$I_F=15A$	-	1.2	2.0	V
Reverse recovery time	T_{rr}	$I_F=15A$ $di/dt=200A/\mu S$	-	330	360	ns
Diode Peak Reverse Recovery Current	I_{rr}		-	30	40	A
Reverse recovery charge	Q_{rr}		-	4770	6600	nC

电参数曲线图 / Electrical Characteristic Curve

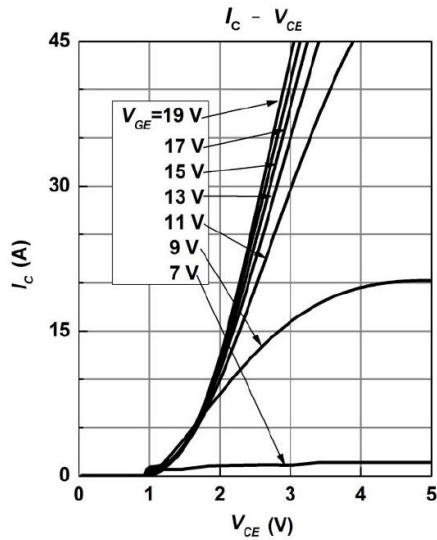
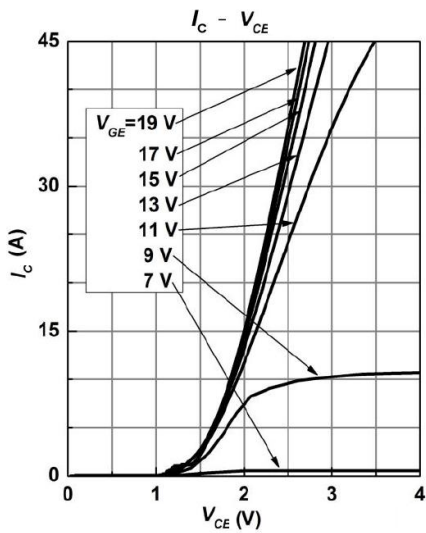
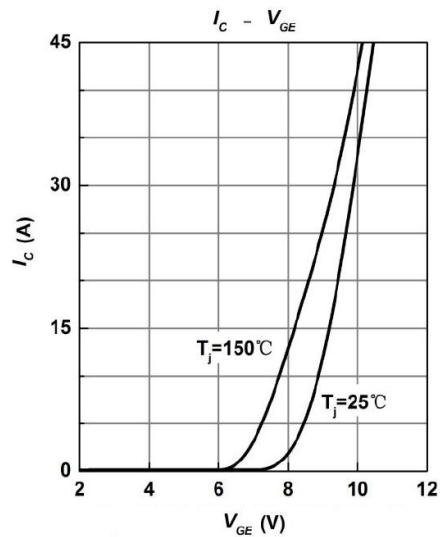
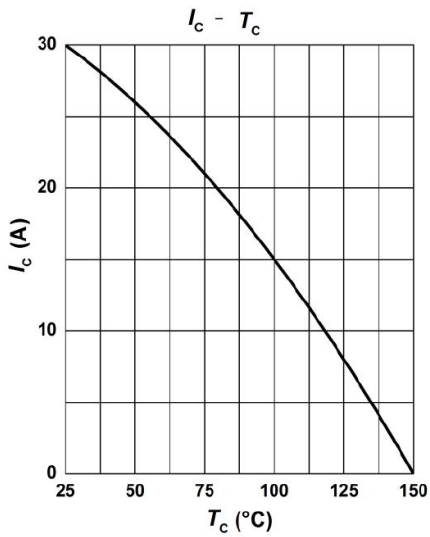
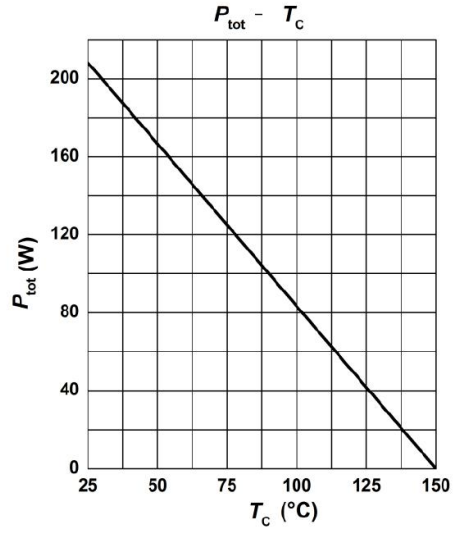
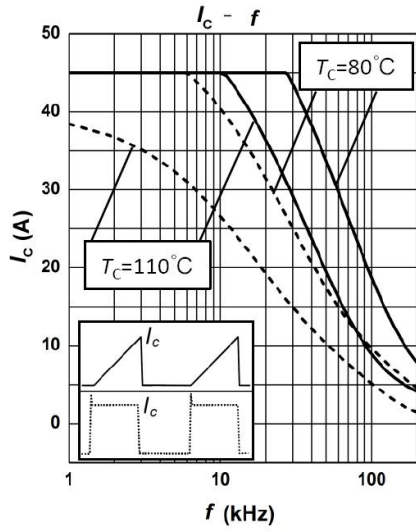

电参数曲线图 / Electrical Characteristic Curve

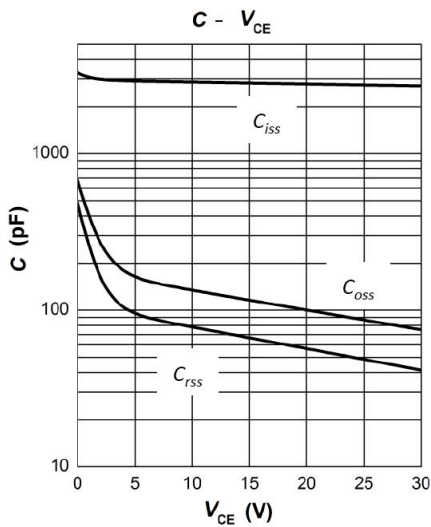
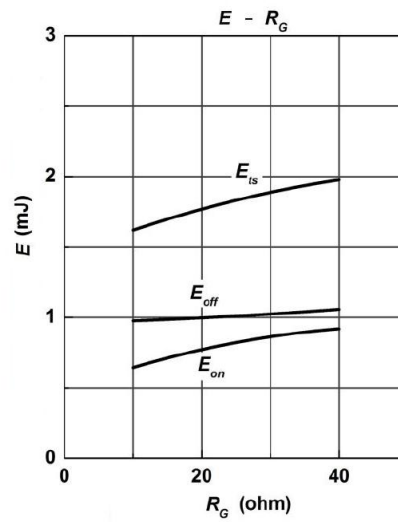
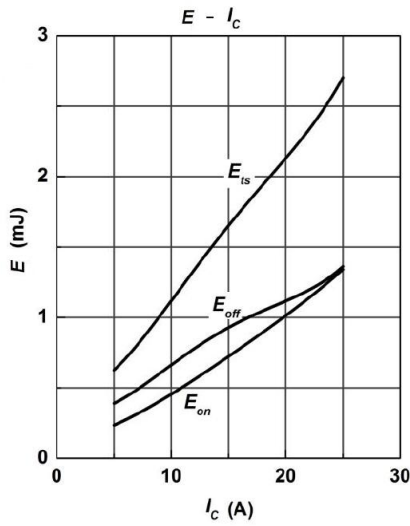
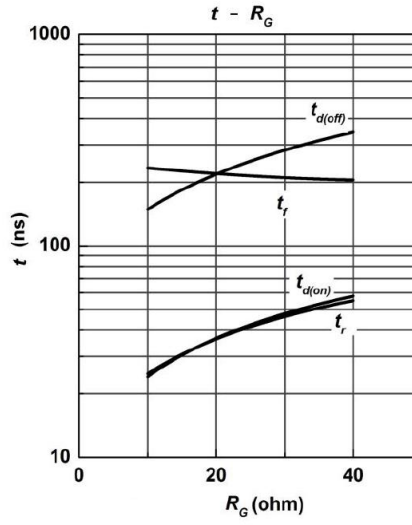
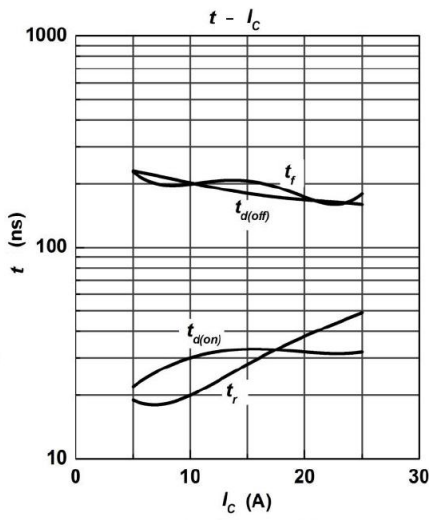

波形图 / Wave curve

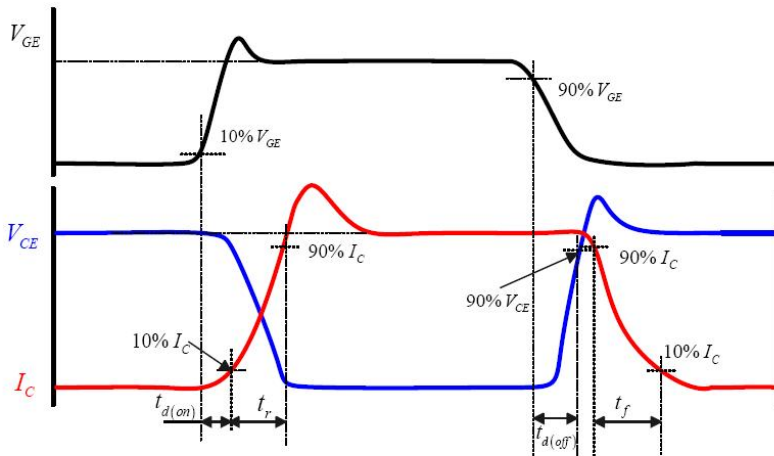

Figure A. Definition of switching times

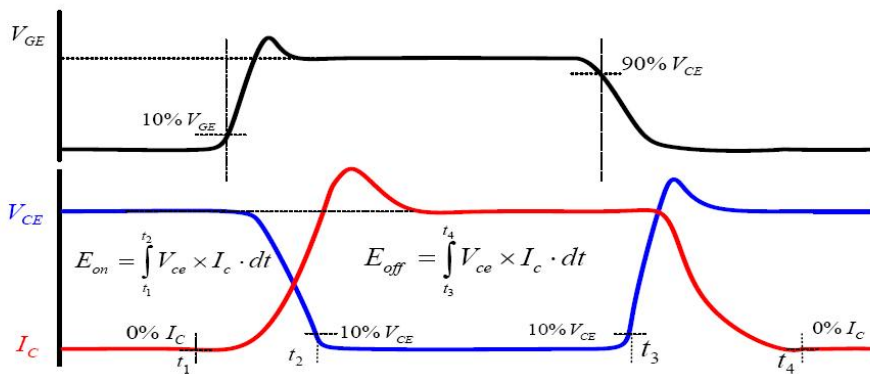

Figure B. Definition of switching losses

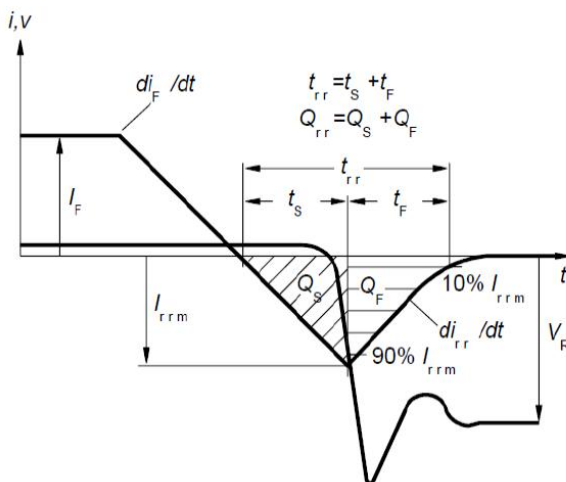

Figure C. Definition of diodes switching characteristics

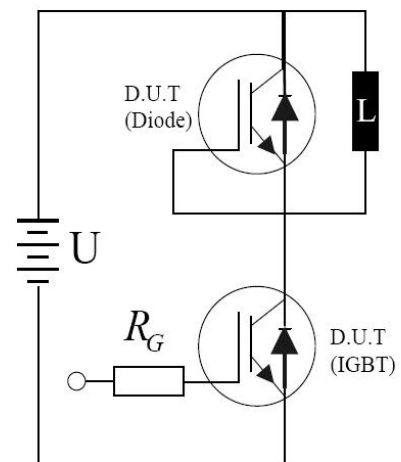
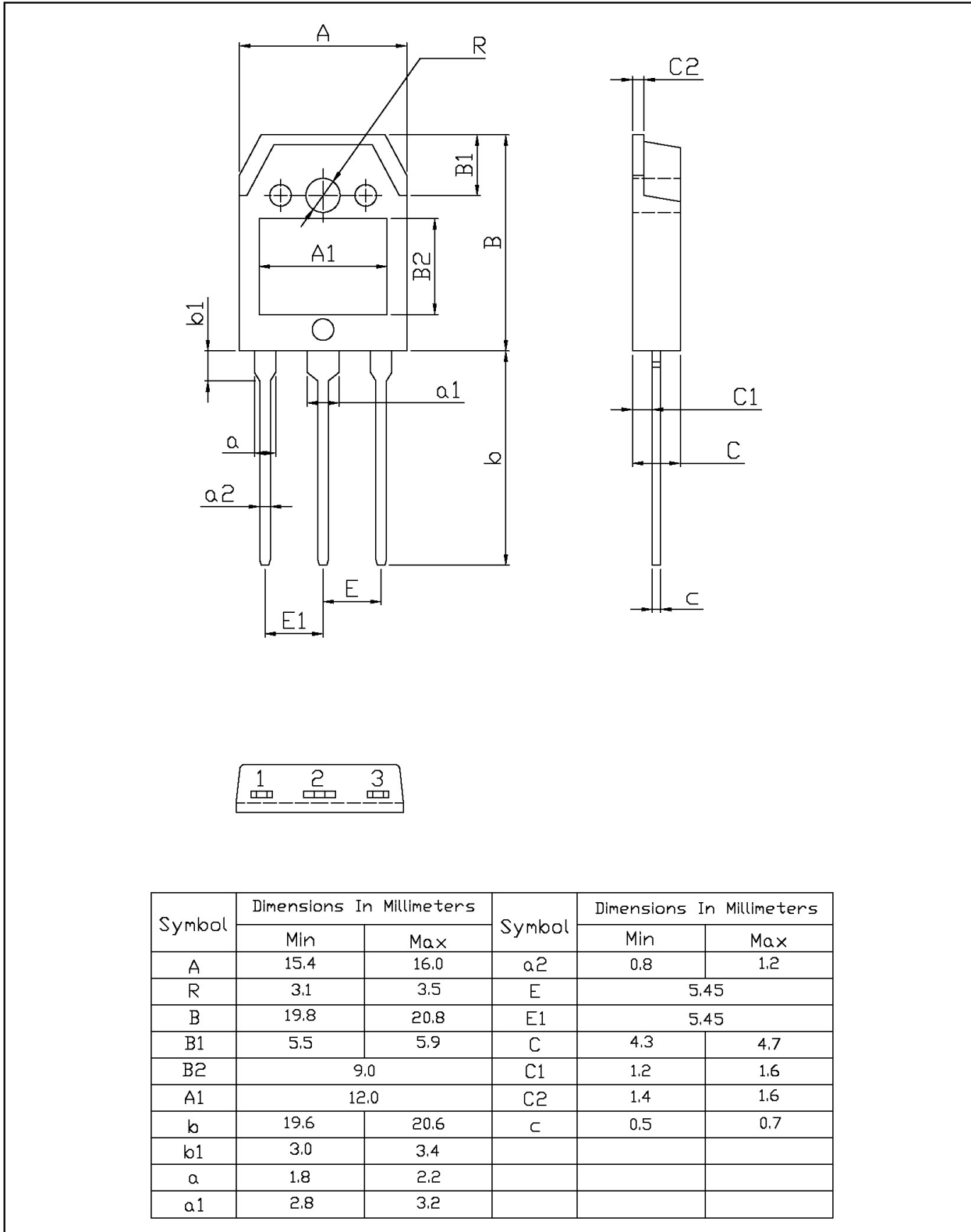

Figure D. Dynamic test circuit

外形尺寸图 / Package Dimensions

TO-3P

单位: mm



印章说明 / Marking Instructions

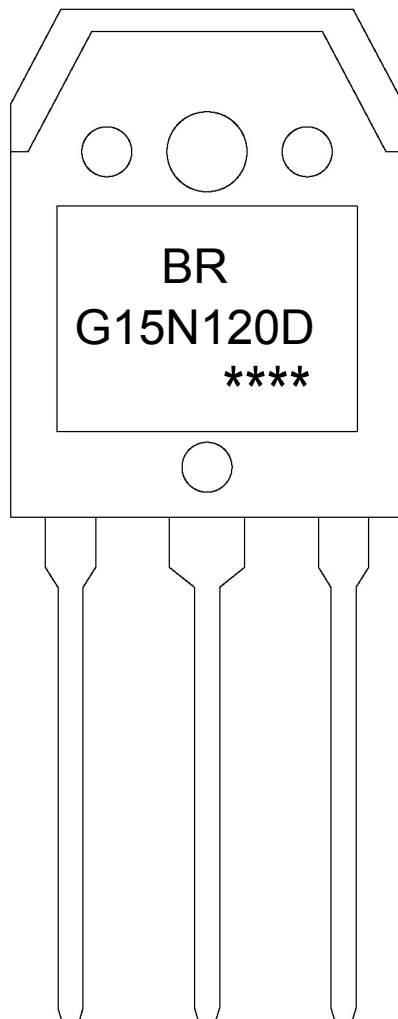

说明：

BR: 为公司代码

G15N120D : 为产品型号

**** : 为生产批号代码，随生产批号变化。

Note:

BR: Company Code.

G15N120D: Product Type.

****: Lot No. Code, code change with Lot No.

波峰焊温度曲线图(无铅) / Temperature Profile for Dip Soldering(Pb-Free)

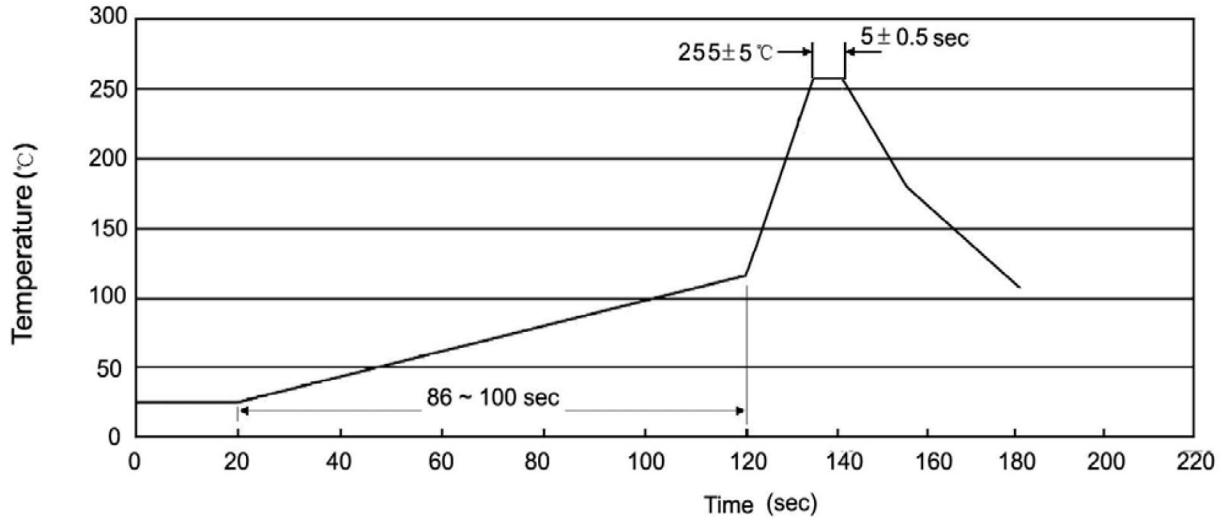

说明：

- 1、预热温度 25~150°C，时间 60~90sec;
- 2、峰值温度 255±5°C，时间持续为 5±0.5sec;
- 3、焊接制程冷却速度为 2~10°C/sec.

Note:

- 1.Preheating:25~150°C, Time:60~90sec.
- 2.Peak Temp.:255±5°C, Duration:5±0.5sec.
3. Cooling Speed: 2~10°C/sec.

耐焊接热试验条件 / Resistance to Soldering Heat Test Conditions

温度：270±5°C 时间：10±1 sec. Temp.:270±5°C Time:10±1 sec

包装规格 / Packaging SPEC.

套管包装 / TUBE

Package Type 封装形式	Units 包装数量					Dimension 包装尺寸 (unit: mm ³)		
	Units/Tube 只/套管	Tubes/Inner Box 套管/盒	Units/Inner Box 只/盒	Inner Boxes/Outer Box 盒/箱	Units/Outer Box 只/箱	Tube 套管	Inner Box 盒	Outer Box 箱
TO-3P	30	15	450	5	2250	497.5×46×8	555×164×50	575×290×180

使用说明 / Notices