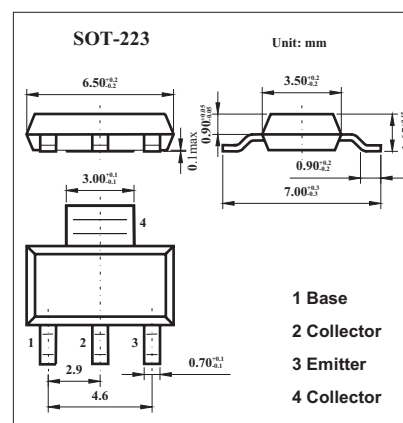

NPN Silicon Epitaxial Transistor

BSP20A

■ Features

- High Voltage: $V_{(BR)CEO}$ of 250 and 350 Volts.
- Available in 12 mm Tape and Reel

■ Absolute Maximum Ratings $T_a = 25^\circ\text{C}$

Parameter	Symbol	Rating	Unit
Collector-Emitter Voltage (Open Base)	V_{CEO}	250	V
Collector-Base Voltage (Open Emitter)	V_{CBO}	300	V
Emitter-Base Voltage (Open Collector)	V_{EBO}	5	V
Collector Current (DC)	I_C	1000	mA
Total Power Dissipation @ $T_A = 25^\circ\text{C}$ *	P_D	0.8	Watts
Derate above 25°C		6.4	mW/ $^\circ\text{C}$
Storage Temperature Range	T_{stg}	-65 to 150	$^\circ\text{C}$
Junction Temperature	T_J	150	$^\circ\text{C}$
Thermal Resistance from Junction-to-Ambient	$R_{\theta JA}$	156	$^\circ\text{C}/\text{W}$
Maximum Temperature for Soldering Purposes	T_L	260	$^\circ\text{C}$
Time in Solder Bath		10	Sec

* Device mounted on a FR-4 glass epoxy printed circuit board using minimum recommended footprint.

■ Electrical Characteristics $T_a = 25^\circ\text{C}$

Parameter	Symbol	Testconditions	Min	Typ	Max	Unit
Collector-Emitter Breakdown Voltage	$V_{(BR)CEO}$	$I_C = 1.0 \text{ mA}, I_B = 0$	250			V
Collector-Base Cutoff Current	I_{CBO}	$V_{CB} = 400 \text{ V}, I_E = 0$			20	nA
Emitter-Base Cutoff Current	I_{EBO}	$V_{EB} = 5.0 \text{ V}, I_C = 0$			10	mA
DC Current Gain *	h_{FE}	$I_C = 20 \text{ mA}, V_{CE} = 10 \text{ V}$	40			
Current-Gain □ Bandwidth Product *	f_T	$I_C = 10 \text{ mA}, V_{CE} = 10 \text{ V}, f = 5.0 \text{ MHz}$	70			MHz
Collector-Emitter Saturation Voltage *	$V_{CE(sat)}$	$I_C = 50 \text{ mA}, I_B = 4.0 \text{ mA}$			0.5	V
Base-Emitter Saturation Voltage *	$V_{BE(sat)}$	$I_C = 50 \text{ mA}, I_B = 4.0 \text{ mA}$			1.3	V

* Pulse Test: Pulse Width $\leq 300 \mu\text{s}$, Duty Cycle = 2.0%

■ Marking

Marking	SP20A
---------	-------