

BT139

Rev.E Mar.-2016

描述 / Descriptions

TO-220 塑封封装 双向可控硅。 Triac in a TO-220 Plastic Package.

特征 / Features

采用玻璃钝化技术，采用环氧塑脂塑料封装，四个信号区都可以满足高灵敏度需要。

glass passivated, sensitive gate triacs in a plastic envelope, where high sensitivity is required in all four quadrants.

用途 / Applications

用于一般双向开关和相位控制。

Use in general purpose bidirectional switching and phase control applications.

内部等效电路 / Equivalent Circuit

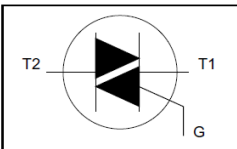

引脚排列 / Pinning

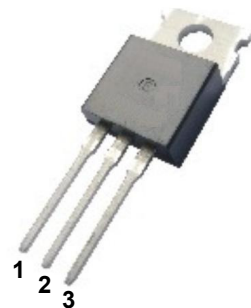

PIN1: Main Terminal 1 PIN 2: Main Terminal 2 PIN 3: Gate

放大及印章代码 / h_{FE} Classifications & Marking

见印章说明。 See Marking Instructions.

极限参数 / Absolute Maximum Ratings(Ta=25°C)

参数 Parameter	符号 Symbol	数值 Rating		单位 Unit
		600E	800E	
Repetitive peak off-state voltages	V_{DRM} ($T_j=25^\circ\text{C}$)	600	800	V
RMS on-state current	$I_{T(RMS)}$	16		A
Non-repetitive peak on-state current	$I_{TSM}(t=20\text{ms})$	155		A
Non-repetitive peak on-state current	$I_{TSM}(t=16.7\text{ms})$	170		A
I_t^2 for fusing	$I_t^2(t=10\text{ms})$	120		A ² S
Repetitive rate of rise of on-state current after triggering	$I_{TM}=12\text{A}$ $I_G=0.2\text{A}$ $di_G/dt=0.2\text{A}/\mu\text{s}$	T2+G+	50	A/ μS
		T2+G-	50	A/ μS
		T2-G-	50	A/ μS
		T2-G+	10	A/ μS
Peak gate current	I_{GM}	2.0		A
Peak gate voltages	V_{GM}	5.0		V
Peak gate power	P_{GM}	5.0		W
Average gate power (Over any 20 ms period)	$P_{G(AV)}$	0.5		W
Junction Temperature	T_j	125		°C
Storage Temperature Range	T_{stg}	-40~150		°C
Thermal resistance junction to ambient	$R_{th(j-a)}$	60		K/W
Thermal resistance junction to mounting base	$R_{th(j-b)}$	1.2		K/W

电性能参数 / Electrical Characteristics(Ta=25°C)

参数 Parameter	符号 Symbol	测试条件 Test Conditions	最小值 Min	典型值 Typ	最大值 Max	单位 Unit
Gate trigger current	I_{GT}	$V_D=12\text{V}$ $I_T=0.1\text{A}$	T2+G+	2.5	10	mA
			T2+G-	4	10	
			T2-G-	5	10	
			T2-G+	11	25	
Latching current	I_L	$V_D=12\text{V}$ $I_G=0.1\text{A}$	T2+G+		30	mA
			T2+G-		40	
			T2-G-		30	
			T2-G+		40	
Holding current	I_H	$V_D=12\text{V}$ $I_G=0.1\text{A}$			45	mA
On-state voltage	V_T	$I_T=20\text{A}$		1.2	1.6	V
Gate trigger voltage	V_{GT}	$V_D=12\text{V}$ $I_T=0.1\text{A}$		0.7	1.5	V
		$V_D=400\text{V}$ $I_T=0.1\text{A}$, $T_j=125^\circ\text{C}$	0.25	0.4		
Off-state leakage current	I_D	$V_D=V_{DRM(max)}$ $T_j=125^\circ\text{C}$		0.1	0.5	mA
Critical rate of rise of off-state current	t_{gt}	$I_{TM}=20\text{A}$ $V_D=V_{DRM(max)}$ $I_G=0.1\text{A}$ $di_G/dt=5\text{A}/\mu\text{s}$		2.0		μs
Repetitive peak off-state current	dV_D/dt	$V_{DM}=67\% V_{DRM(MAX)}$ $T_j=125^\circ\text{C}$		50		V/ μs

电参数曲线图 / Electrical Characteristic Curve

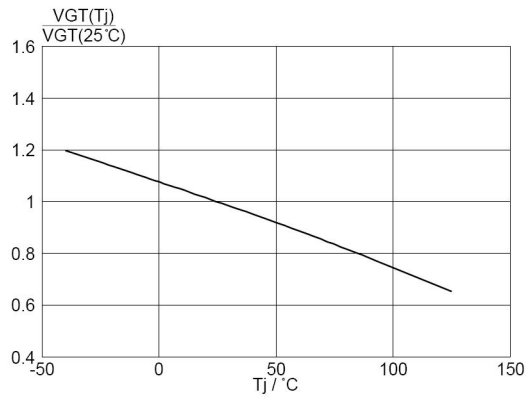
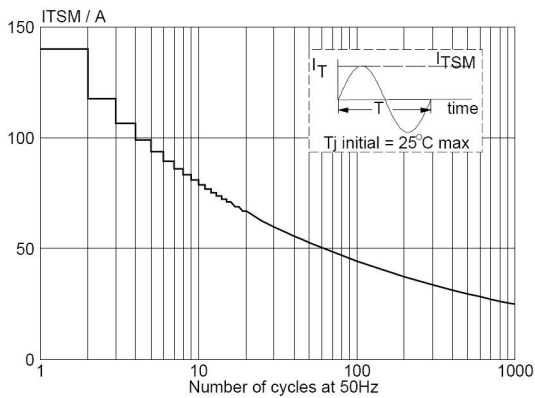
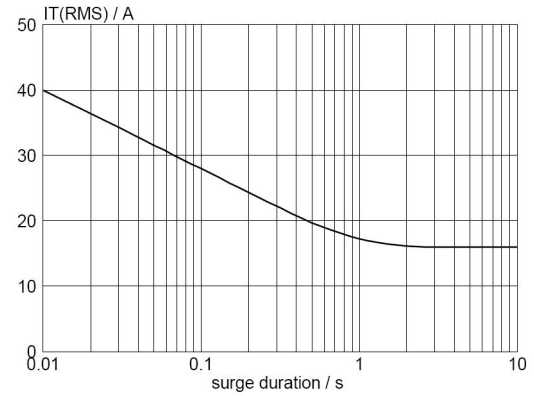
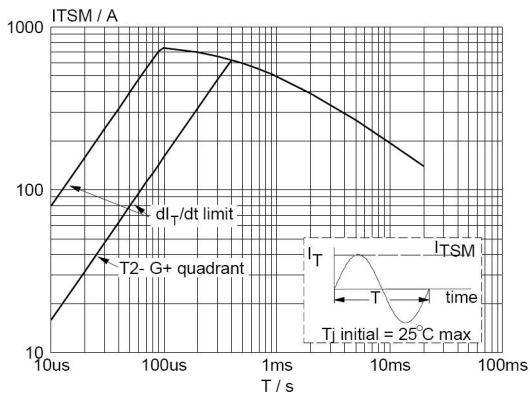
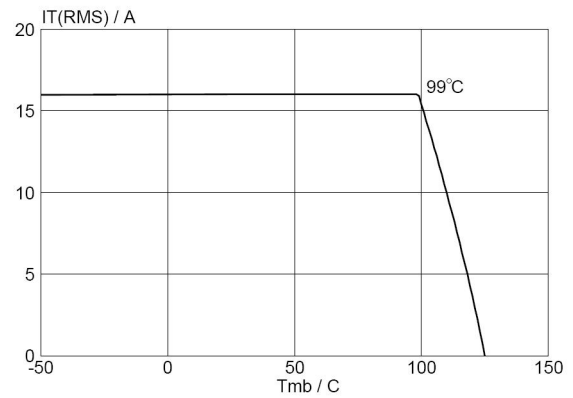
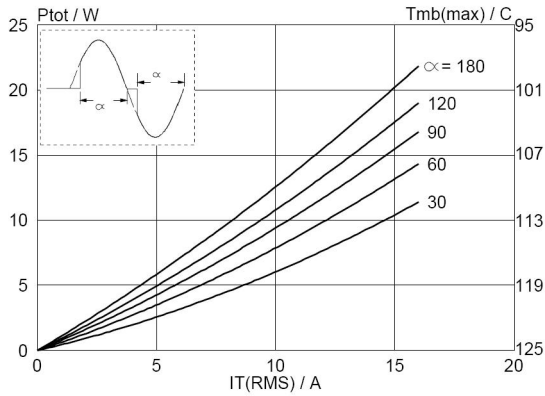

电参数曲线图 / Electrical Characteristic Curve

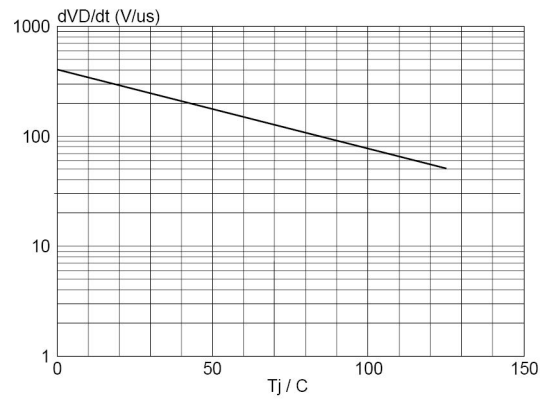
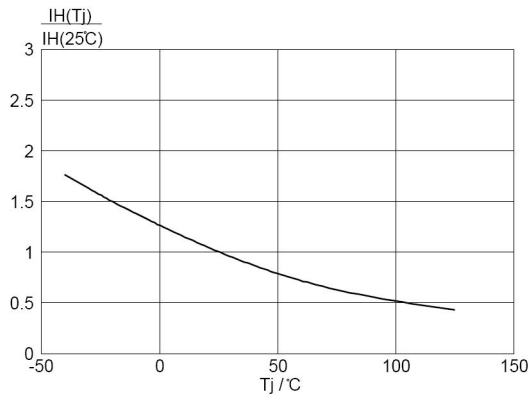
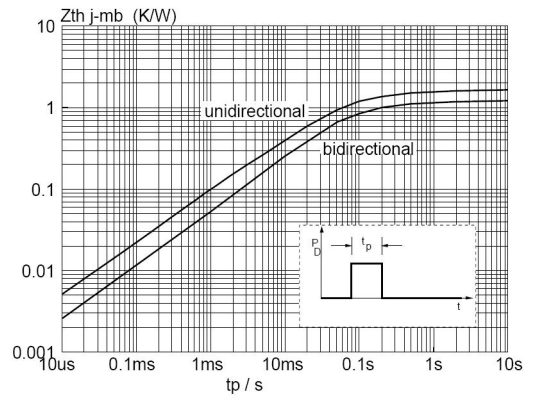
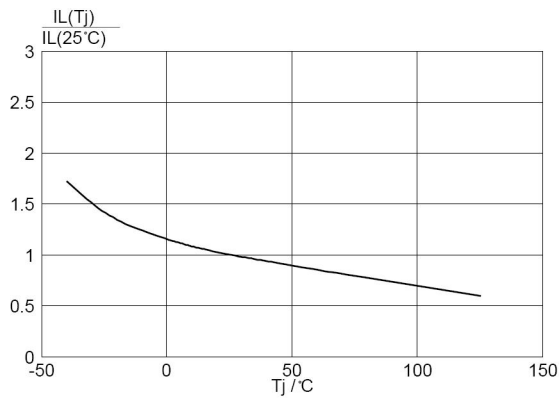
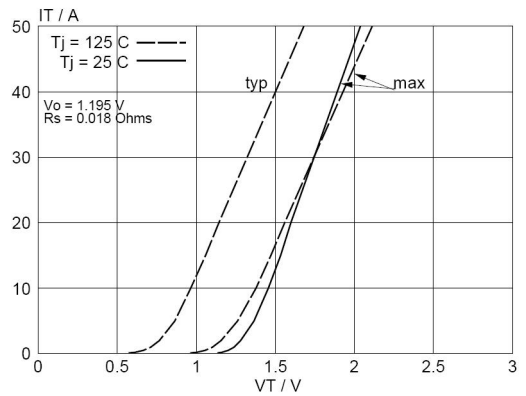
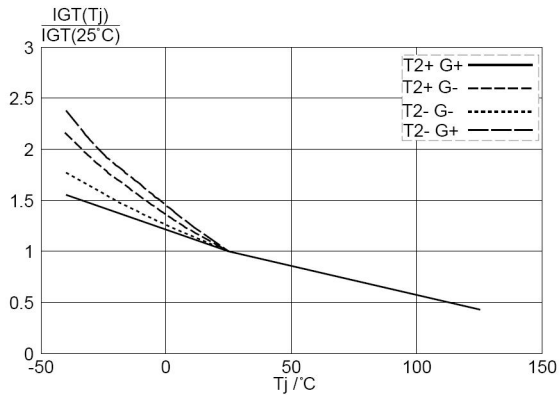

外形尺寸图 / Package Dimensions

T□-220

单位: mm

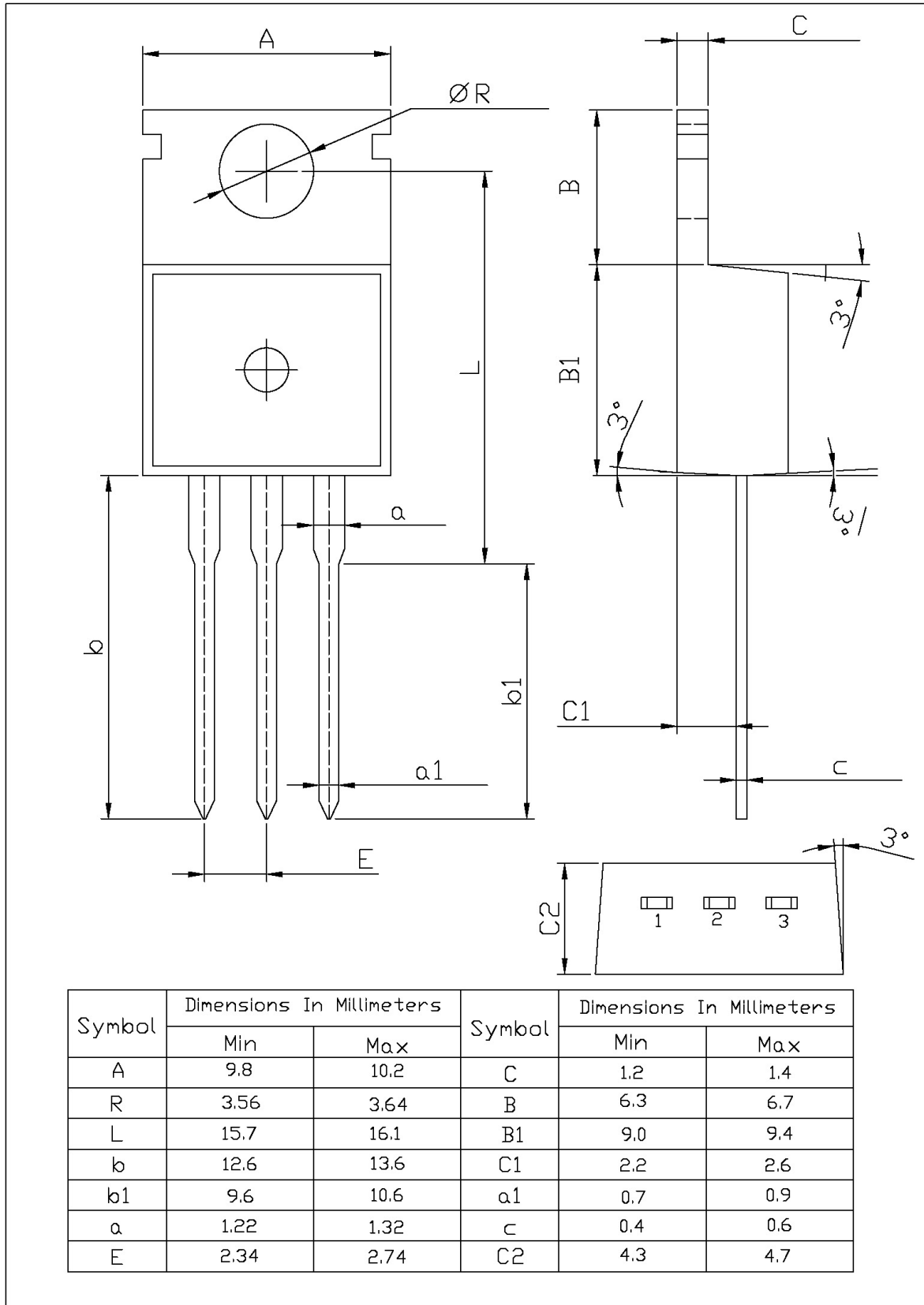

印章说明 / Marking Instructions

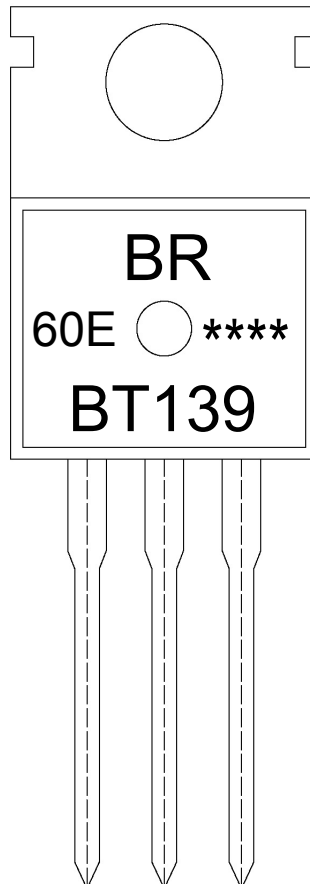

说明：

BR： 为公司代码

BT139： 为产品型号

60E： 为耐压分档

****： 为生产批号代码，随生产批号变化。

Note:

BR: Company Code

BT139: Product Type.

60E: Withstand Voltage Symbol.

****: Lot No. Code, code change with Lot No.

波峰焊温度曲线图(无铅) / Temperature Profile for Dip Soldering(Pb-Free)

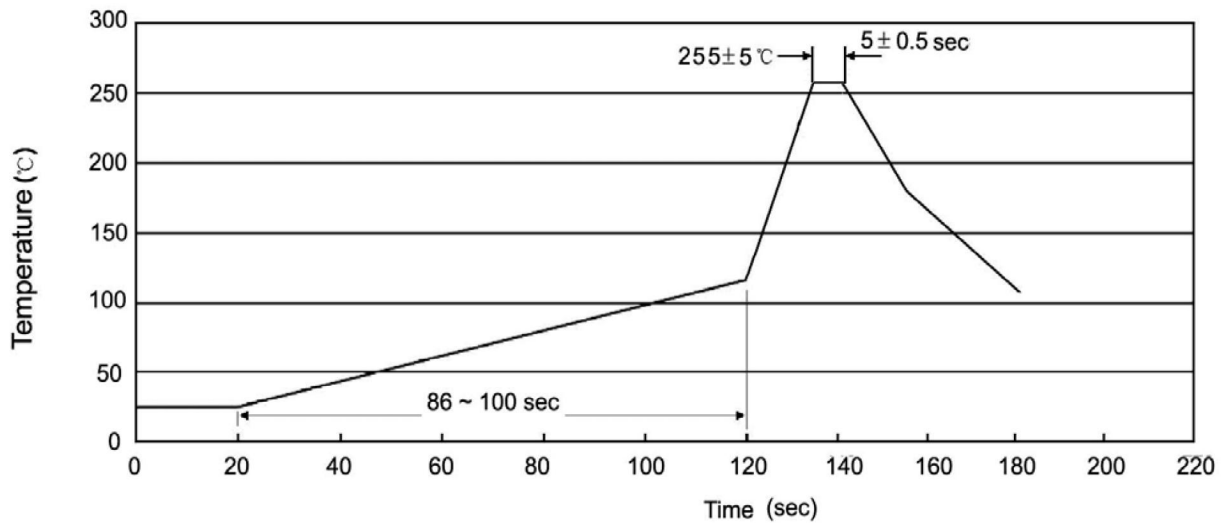

说明：

- 1、预热温度 25 ~ 150°C，时间 60 ~ 90sec;
- 2、峰值温度 255±5°C，时间持续为 5±0.5sec;
- 3、焊接制程冷却速度为 2 ~ 10°C/sec.

Note:

- 1.Preheating:25~150°C, Time:60~90sec.
- 2.Peak Temp.:255±5°C, Duration:5±0.5sec.
3. Cooling Speed: 2~10°C/sec.

耐焊接热试验条件 / Resistance to Soldering Heat Test Conditions

温度：270±5°C

时间：10±1 sec.

Temp.:270±5°C

Time:10±1 sec

包装规格 / Packaging SPEC.

散件包装 / BULK

Package Type 封装形式	Units 包装数量					Dimension 包装尺寸 (unit: mm ³)		
	Units/Bag 只/袋	Bags/Inner Box 袋/盒	Units/Inner Box 只/盒	Inner Boxes/Outer Box 盒/箱	Units/Outer Box 只/箱	Bag 袋	Inner Box 盒	Outer Box 箱
TO-220/F	200	10	2,000	5	10,000	135×190	237×172×102	560×245×195

套管包装 / TUBE

Package Type 封装形式	Units 包装数量					Dimension 包装尺寸 (unit: mm ³)		
	Units/Tube 只/套管	Tubes/Inner Box 套管/盒	Units/Inner Box 只/盒	Inner Boxes/Outer Box 盒/箱	Units/Outer Box 只/箱	Tube 套管	Inner Box 盒	Outer Box 箱
TO-220/F	50	20	1,000	5	5,000	532×31.4×5.5	555×164×50	575×290×180

使用说明 / Notices